

# Customer Information Sheet

DRAWING No.: M80-809XXXX

SHEET 2 OF 2

IF IN DOUBT - ASK

©

NOT TO SCALE

THIRD ANGLE PROJECTION

ALL DIMENSIONS IN mm

ORDER CODE:

**M80-809XXXX**

TOTAL No. OF WAYS

02, 03, 04, 05, 06, 07

FINISH

05 - GOLD

**SPECIFICATIONS:**

**MATERIAL:**

MOULDING = GLASS-FILLED  
POLYAMIDE 46 UL94V-0

CONTACTS = BRASS

LATCH = BERYLLIUM COPPER

**FINISH:**

**CONTACTS:**

05 = 0.25-0.30µ GOLD

LATCH = 1.25µ NICKEL

**ELECTRICAL:**

CURRENT RATING AT 25°C = 3.0A MAX

CURRENT RATING AT 85°C = 2.2A MAX

WORKING VOLTAGE = 120V AC/DC

VOLTAGE PROOF = 360V AC/DC

CONTACT RESISTANCE (INITIAL) = 20 mΩ MAX

CONTACT RESISTANCE (AFTER CONDITIONING) = 25 mΩ MAX

INSULATION RESISTANCE (INITIAL) = 1,000 MΩ MIN

INSULATION RESISTANCE (AFTER CONDITIONING) = 100 MΩ MIN

**MECHANICAL:**

DURABILITY = 500 OPERATIONS

**ENVIRONMENTAL:**

TEMPERATURE RANGE = -55°C TO +125°C

**PACKING:**

BAG (CONTACTS AND MOULDINGS UN-ASSEMBLED)

FOR COMPLETE SPECIFICATION, SEE COMPONENT  
SPECIFICATION C005XX (LATEST ISSUE)

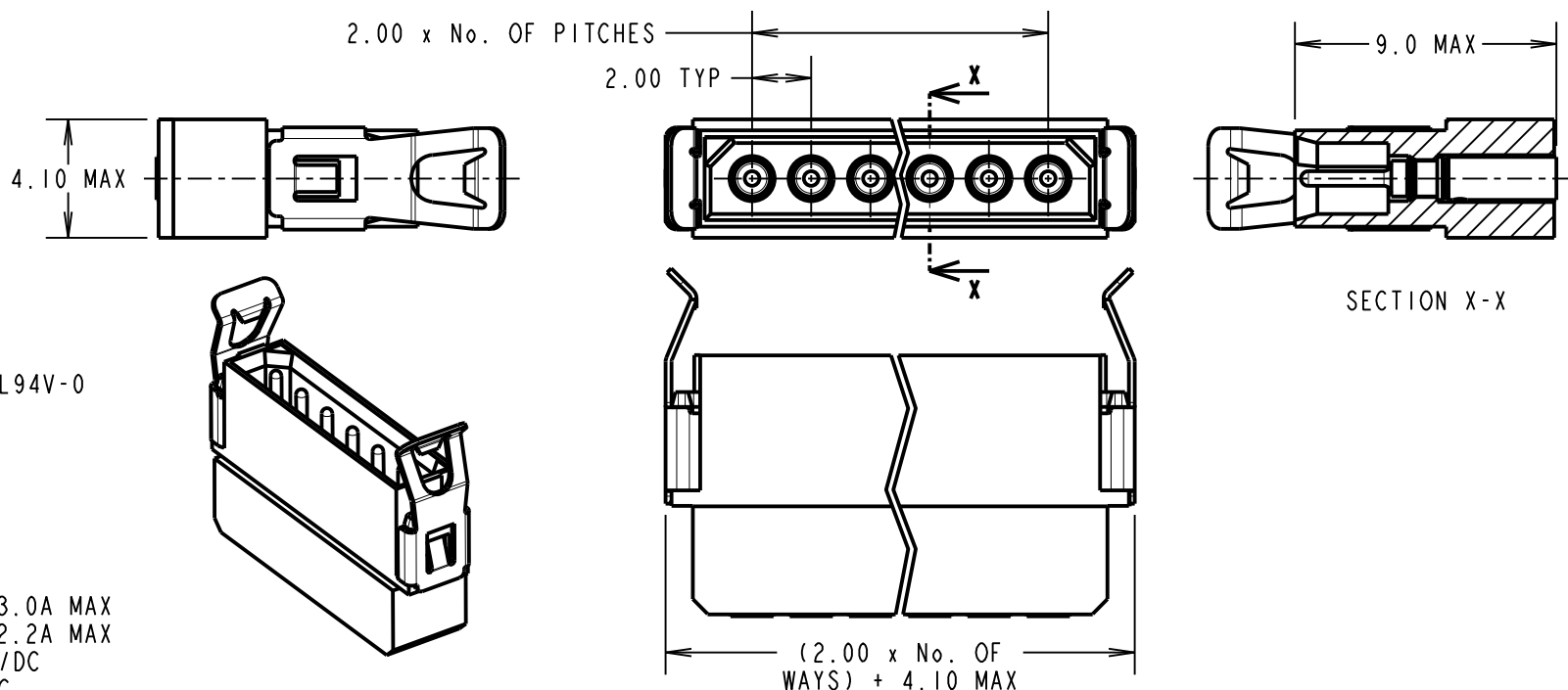

**NOTES:**

1. RECOMMENDED WIRE TYPE = BS3G210 TYPE A, PTFE INSULATED, 22 AWG. MAX INSULATION DIAMETER = Ø1.10mm, STRIP WIRE BY 2.00mm.
2. RECOMMENDED HAND CRIMP TOOL = M22520/2-01 WITH POSITIONER T5747. REFER TO TOOLING INSTRUCTION SHEET IS-01 FOR COMPLETE CRIMPING INSTRUCTIONS.
3. CONTACT INSERTION AND EXTRACTION TOOL = Z80-280. REFER TO TOOLING INSTRUCTION SHEET IS-25 FOR ASSEMBLY INSTRUCTIONS.
4. CONNECTORS ARE SUPPLIED WITH CONTACTS LOOSE.
5. FOR EXTRA CONTACTS USE PART NUMBER M80-0400005.

MGP	3	29.07.11	11396
NAME	ISS.	DATE	C/NOTE
APPROVED: MGP			
CHECKED: RA			
DRAWN:		W. J. BOURNE	
CUSTOMER REF.:			
ASSEMBLY DRG:			

**HARWIN**

THIS DRAWING AND ANY INFORMATION OR DESCRIPTIVE MATTER SET OUT HEREON ARE CONFIDENTIAL AND COPYRIGHT PROPERTY OF THE HARWIN GROUP AND MUST NOT BE DISCLOSED, LOANED, COPIED OR USED FOR MANUFACTURING, TENDERING OR FOR ANY OTHER PURPOSE WITHOUT THEIR WRITTEN PERMISSION.

**TOLERANCES**

X. = ±1mm  
X.X = ±0.25mm  
X.XX = ±0.10mm  
X.XXX = ±0.01mm

ANGLES = ±5°

UNLESS STATED

**MATERIAL:**

SEE ABOVE

**FINISH:**

**S/AREA:**

mm<sup>2</sup>

**TITLE:**

DATAMATE 2mm PITCH  
CRIMP SIL LATCH PLUG ASSY  
LARGE BORE (22 AWG)

**DRAWING NUMBER:**

**M80-809XXXX**

SHT  
2 OF 2

HARWIN USA  
TEL: 603 893 5376  
FAX: 603 893 5396  
mis@harwin.com

HARWIN Europe (UK)  
TEL: 023 9231 4545  
FAX: 023 9231 4590  
mis@harwin.co.uk

HARWIN Asia  
TEL: +65 6 779 4909  
FAX: +65 6 779 3868  
mis@harwin.com.sg