

THIS DRAWING AND THE INFORMATION SET FORTH HEREON ARE THE PROPERTY OF TYCO ELECTRONICS AND ARE TO BE HELD IN TRUST AND CONFIDENCE. PUBLICATION, DUPLICATION, DISCLOSURE, OR USE FOR ANY PURPOSE NOT EXPRESSLY AUTHORIZED IN WRITING BY TYCO ELECTRONICS IS PROHIBITED.

REVISIONS			
LTR	DESCRIPTION	DATE	APPROVED
A	INITIAL PER ECO-11-022898	11/14/11	B. WONG

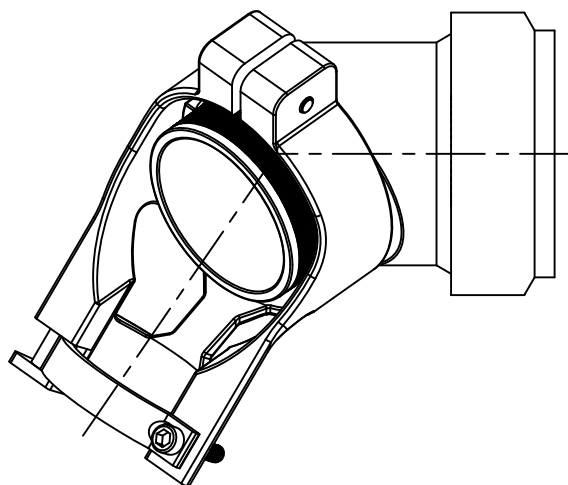

SPIN-LOCK ADAPTER, SADDLE CLAMP

NOTES:

1. THIS PRODUCT IS DESIGNED TO TERMINATE A BRAIDED CABLE SHIELD TO A CONNECTOR AND PROVIDE STRAIN RELIEF.
2. SEE DRAWING "TR" FOR DETAIL ON TINEL-LOCK RING. RINGS ARE DESIGNED TO BE HEATED ELECTRICALLY. ALL RINGS ARE MARKED WITH THERMOCHROMIC PAINT WHICH CHANGES COLOR WHEN INSTALLATION TEMPERATURE IS REACHED.
3. ADAPTER TO BE PERMANENTLY MARKED WITH CODE IDENT. NO. AND PART NO. LESS RING DESIGNATOR (E.G.: 06090-XXXXXXX-XXXXX).
4. ADAPTER MATES TO MIL-C-38999, SERIES III & IV, CLASS C, F, K, & W; D38999 /20, /24, /26, /40, /46, /47 CONNECTORS, WHEN SO MATED SHALL PROVIDE WATER-TIGHT SEAL MEETING THE REQUIREMENTS OF MIL-C-85049, PAR. 3.5.7.
5. INSTALLATION PROCEDURE MIP-103.
6. PERFORMANCE SPECIFICATION MPS-103.
7. FOR ADDITIONAL ORDERING INFORMATION SEE CH00-0250-019.

If this document is printed it becomes uncontrolled. Check for the latest revision

©2011 Tyco Electronics Corporation. All rights reserved.

Raychem Adapters  
CUSTOMER DRAWING

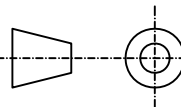
UNLESS OTHERWISE SPECIFIED DIMENSIONS ARE IN INCHES AND TOLERANCES ARE: .XXX ± — .XX ± — ± —	DRAWN D JAIN	DATE 8AUG2011		TE Connectivity	
	CHECKED BERT W	DATE 8AUG2011			
MATERIAL SEE NOTES	APPROVED	DATE	TITLE SPIN-LOCK ADAPTER SADDLE CLAMP, CODE 40		
	THIRD ANGLE PROJECTION				
FINISH —	CAD NAME SLC40_a.dwg	SIZE A	CAGE CODE: 06090	DWG. NO. SLC40	REV A
	RPN: —	SCALE: NONE	SHEET 1 OF 3		

REVISIONS			
LTR	DESCRIPTION	DATE	APPROVED
A	INITIAL RELEASE PER ECO-11-022898	11/14/11	B. WONG

e.g. SLC40AB-1610A

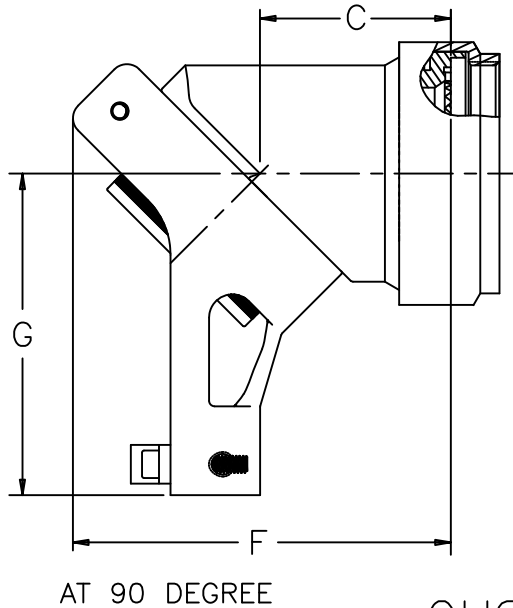
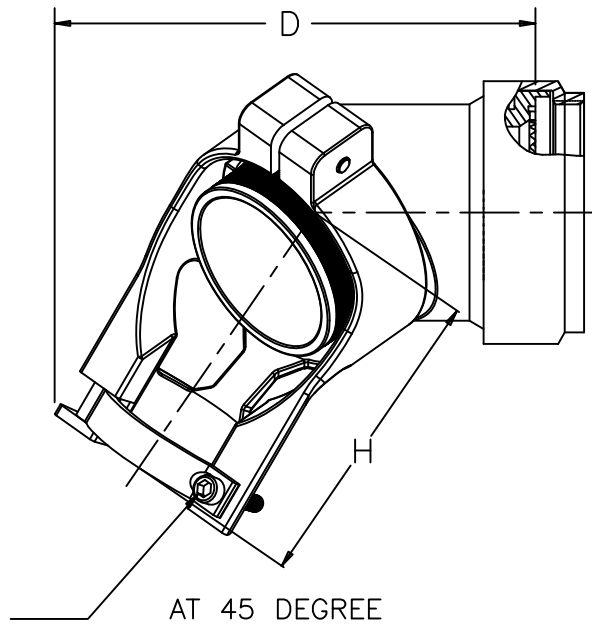
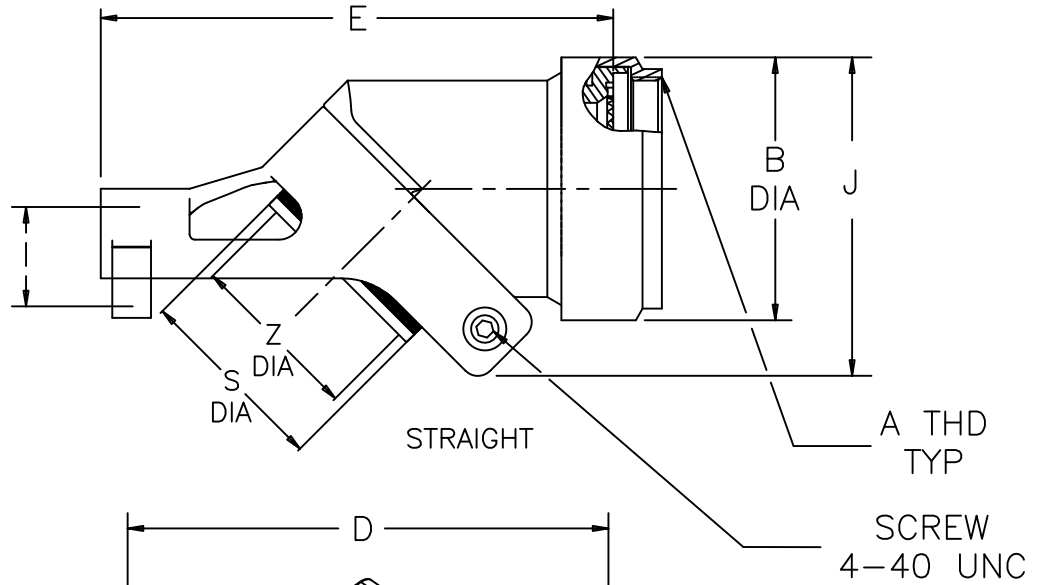

Raychem Adapters  
CUSTOMER DRAWING

SIZE A	CAGE CODE: 06090	DWG. NO. SLC40	REV A
SCALE: NONE		SHEET 2 OF 3	

REVISIONS			
LTR	DESCRIPTION	DATE	APPROVED
A	INITIAL RELEASE PER ECO-11-022898	11/14/11	B. WONG

TABLE I

ORDER NO.	SHELL SIZE 4		AVAILABLE ENTRY SIZES (SEE TABLE III)		A METRIC THD CLASS 6H	B DIA MAX	C MAX DIM
	COM'L	MIL	SMALL	LARGE			
08	09	A	04	-	M12 x 1.0	.67 [17.02]	.68 [17.27]
10	11	B	04	06	M15 x 1.0	.81 [20.57]	.76 [19.30]
12	13	C	06	08	M18 x 1.0	.96 [24.38]	.85 [21.59]
14	15	D	08	10	M22 x 1.0	1.14 [28.96]	.95 [24.13]
16	17	E	10	12	M25 x 1.0	1.25 [31.75]	1.03 [26.16]
18	19	F	10	14	M28 x 1.0	1.40 [35.56]	1.15 [29.21]
20	21	G	12	16	M31 x 1.0	1.48 [37.59]	1.19 [30.23]
22	23	H	14	18	M34 x 1.0	1.61 [40.89]	1.28 [32.51]
24	25	J	16	20	M37 x 1.0	1.75 [44.45]	1.36 [34.54]

TABLE II

ORDER NO.	D MAX DIM	E MAX DIM	F MAX DIM	G MAX DIM	H MAX DIM	I MAX DIM	J MAX DIM	CLAMP SCREW
08	1.81 [45.97]	1.80 [45.72]	1.27 [32.26]	1.12 [28.45]	1.16 [29.46]	.234 [5.94]	.97 [24.64]	1-64 UNC
10	1.89 [48.01]	2.00 [50.80]	1.35 [34.29]	1.24 [31.50]	1.16 [29.46]	.234 [5.94]	1.09 [27.69]	1-64 UNC
12	1.99 [50.55]	2.15 [54.61]	1.45 [36.83]	1.30 [33.02]	1.16 [29.46]	.328 [8.33]	1.17 [29.72]	1-64 UNC
14	2.09 [53.09]	2.32 [58.93]	1.51 [38.35]	1.37 [34.80]	1.16 [29.46]	.457 [11.61]	1.37 [34.80]	5-40 UNC
16	2.19 [55.63]	2.49 [63.25]	1.60 [40.64]	1.46 [37.08]	1.16 [29.46]	.614 [15.60]	1.50 [38.10]	5-40 UNC
18	2.28 [57.91]	2.79 [70.87]	1.67 [42.42]	1.64 [41.66]	1.16 [29.46]	.634 [16.10]	1.65 [41.91]	5-40 UNC
20	2.34 [59.44]	2.86 [72.64]	1.73 [43.94]	1.67 [42.42]	1.17 [29.72]	.698 [17.73]	1.79 [45.47]	5-40 UNC
22	2.45 [62.23]	3.23 [82.04]	1.81 [45.97]	1.95 [49.53]	1.15 [29.21]	.823 [20.90]	1.89 [48.01]	5-40 UNC
24	2.40 [60.96]	3.31 [84.07]	1.75 [44.45]	1.95 [49.53]	1.12 [28.45]	.853 [21.67]	1.99 [50.55]	5-40 UNC

TABLE III

ENTRY SIZE	S DIA	Z +.010 -.020
04	.376 [9.55] .370 [9.40]	.250 [6.35]
06	.501 [12.73] .495 [12.57]	.375 [9.53]
08	.626 [15.90] .619 [15.72]	.500 [12.70]
10	.752 [19.10] .742 [18.85]	.625 [15.88]
12	.877 [22.28] .867 [22.02]	.750 [19.05]
14	1.002 [25.45] .991 [25.17]	.875 [22.23]
16	1.127 [28.63] 1.116 [28.35]	1.000 [25.40]
18	1.252 [31.80] 1.241 [31.52]	1.125 [28.58]
20	1.377 [34.98] 1.366 [34.70]	1.250 [31.75]

Raychem Adapters

CUSTOMER DRAWING

If this document is printed it becomes uncontrolled. Check for the latest revision

SIZE A	CAGE CODE: 06090	DWG. NO. SLC40	REV A
			SHEET 3 OF 3