

**Extraction Tool 844751-1**

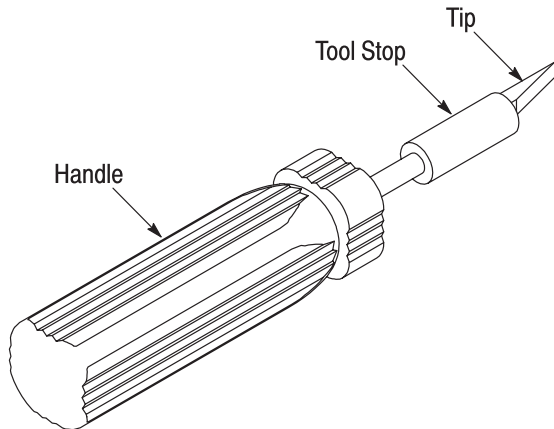



Figure 1

**1. INTRODUCTION**

Extraction Tool 844751-1 shown in Figure 1 is designed to remove Generation II Timer Control Terminals (reference part number 770642-1) from Standard Timer Connectors.

**NOTE**  Dimensions in this instruction sheet are in millimeters [with inches in brackets]. Figures are not drawn to scale.

Reasons for reissue of this instruction sheet are provided in Section 5, REVISION SUMMARY.

**2. DESCRIPTION**

The extraction tool consists of a plastic handle, a steel blade tip with a chamfered edge, and a tool stop.

When inserted into the terminal cavity of the connector, the tip of the tool functions as a release, depressing the locking lance slot of the terminal to allow extraction of the terminal from the connector. The tool stop prevents over insertion of the tip in the cavity and prevents the connector housing from being damaged during the extraction of the terminal.

**3. USING THE TOOL**

1. Align the tool tip with the cavity of the terminal to be removed. The tool tip must be positioned so that the chamfered edge of the tip is facing the locking feature slot of the cavity (this slot is on one side of the cavity only). Refer to Figure 2.
2. Gently insert the tool tip into the cavity until the tool stop butts against the connector. See Figure 3, Detail A.
3. Gently push the tool, and tilt the tip away from the locking feature slot to release the locking lance (inside the connector) from the locking lance slot of the terminal. See Figure 3, Detail B.
4. Simultaneously pull back on the wire to remove the terminal from the wire end of the connector.

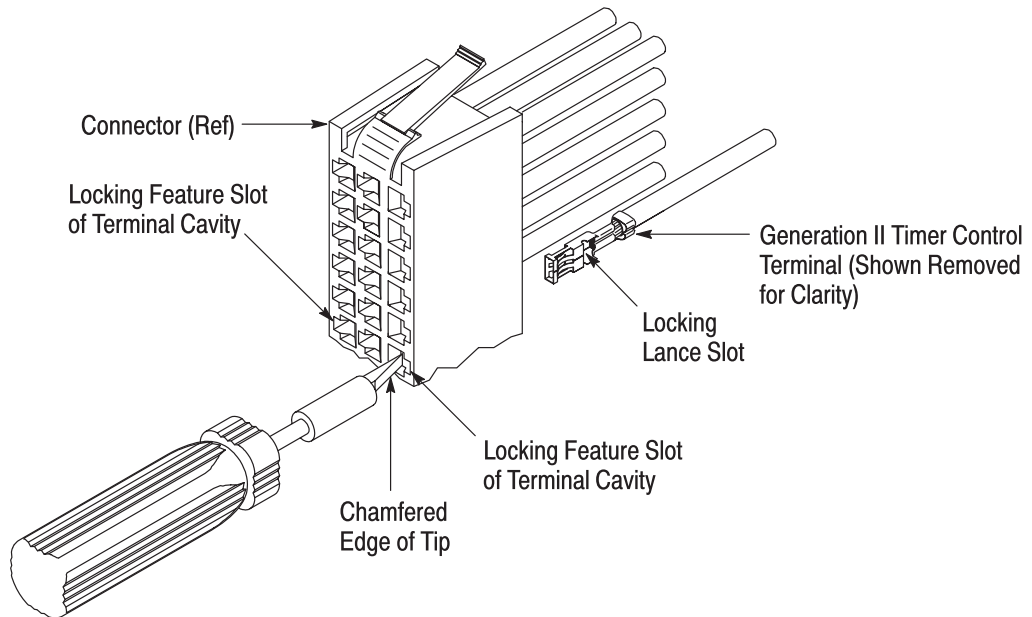

Figure 2

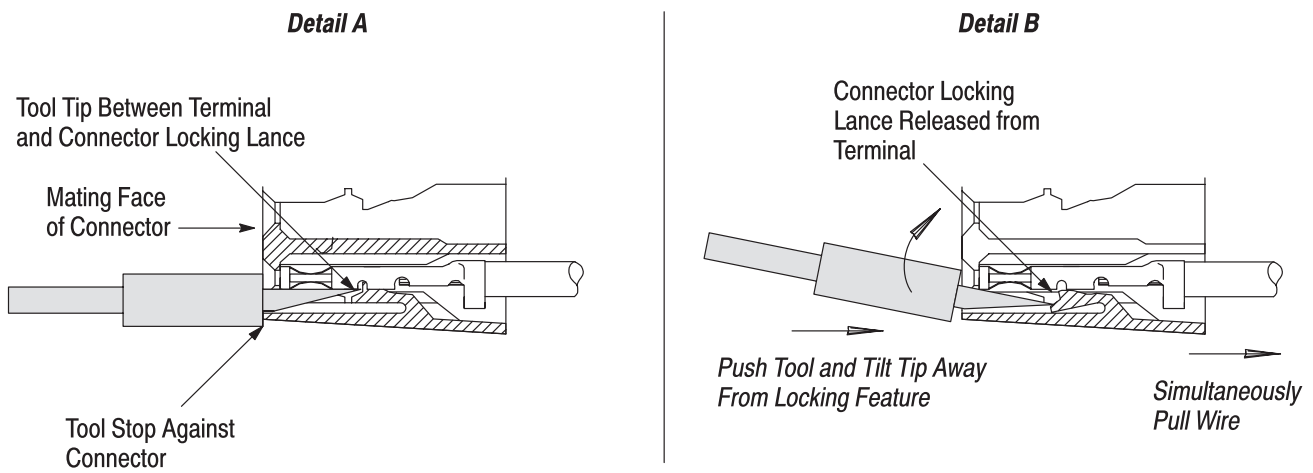

Figure 3



*DO NOT use excessive force when extracting a terminal from its cavity. If there is difficulty in removing the terminal, re-insert the tool tip, making sure the tip is properly positioned in the cavity; then repeat Steps 3 and 4.*

Order replacement tools through your representative, or call 1-800-526-5142, or send a facsimile of your purchase order to 717-986-7605, or write to:

CUSTOMER SERVICE (038-035)  
 TYCO ELECTRONICS CORPORATION  
 PO BOX 3608  
 HARRISBURG PA 17105-3608

**4. INSPECTION AND REPLACEMENT**

It is recommended that the tool be inspected immediately upon arrival at your facility to ensure that the tool has not been damaged during shipment and that the tool conforms to the dimensions provided in Figure 4.

**5. REVISION SUMMARY**

Revisions to this instruction sheet include:

- Updated document to corporate requirements
- Removed superceded terminal part number

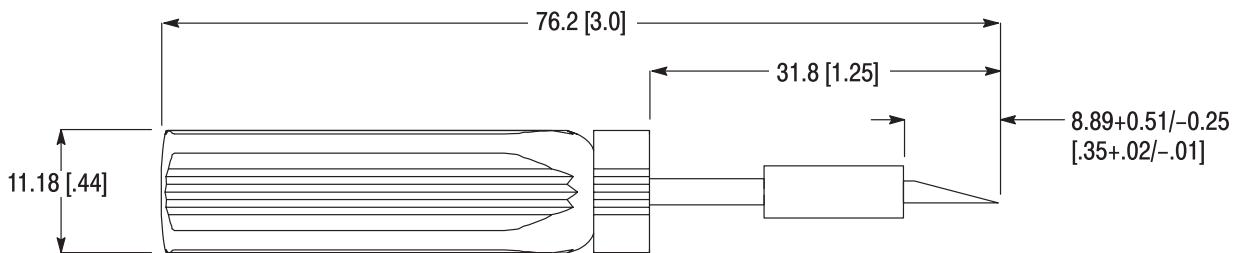

Figure 4