

PART NUMBER		STUD SIZE	DIMENSIONS in.				
PREFIX	PK		A $\pm .03$ (.8)	W $\pm .01$ (.3)	C $\pm .015$ (.4)	M $\pm .03$ (.8)	H $\pm .01$ (.3)
PV18-6LFB	-3K	#6	.80 (20.3)	.27 (6.86)	.19 (4.7)	.60 (15.2)	.15 (3.8)
PV18-6LFWB	-3K	#6	.83 (21.1)	.29 (7.4)	.19 (4.7)	.61 (15.5)	.14 (3.6)
PV18-8LFB	-3K	#8	.87 (22.1)	.29 (7.3)	.23 (5.8)	.65 (16.5)	.16 (4.1)
PV18-10LFB	-3K	#10	.87 (22.1)	.33 (8.3)	.23 (5.8)	.65 (16.5)	.19 (4.8)
PV18-10LFNB*	-3K	#10	.87 (22.1)	.29 (7.2)	.23 (5.8)	.65 (16.5)	.19 (4.8)

NOTES :

- UL LISTED AND CSA CERTIFIED FOR:
  - 600 V MAX. VOLTAGE RATING (1000V. MAX. IN SIGNS, FIXTURES & LUMINARIES)
  - 221°F (105°C) MAX. TEMP. RATING OF INSULATION MATERIAL.
  - #22-18 AWG SOLID OR STRANDED, COPPER WIRE (.5-1.5 mm<sup>2</sup>)
- PACKAGE QTY.: 3K = 3000 PCS.  
CONTINUOUS MOLDED CARRIER STRIP
- MATERIAL:
  - STAMPING - .032 (.81) THK COPPER, TIN PLATED
  - HOUSING - RED VINYL
- WIRE STRIP LENGTH: 1/4  $\begin{matrix} +1/32 \\ -0 \end{matrix}$  (6.3  $\begin{matrix} +.8 \\ -.0 \end{matrix}$ )
- DIMENSIONS IN BRACKETS ARE IN MILLIMETERS OR mm<sup>2</sup>
- INSTALLATION TOOLS:
  - PRESSES - CP-851, CP-860, CP-861, CP-862
  - APPLICATOR - CA-800, CA9
  - DIE INSERTS - CD-800-1, CD9-1A
- MAX. WIRE INSUL. DIA. - .150 (3.81)

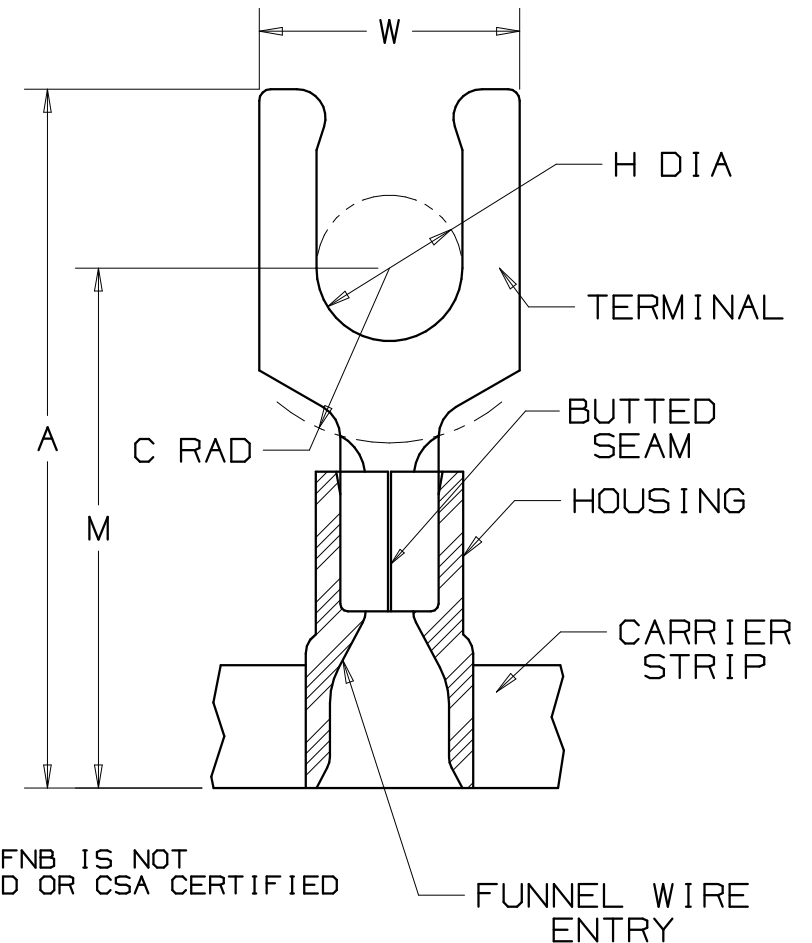

LISTED  
587H  
E52164



CERTIFIED  
LR31212

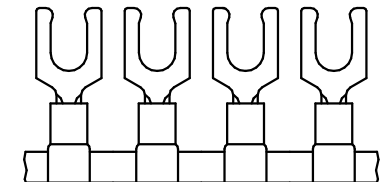

A41072\_07

07	2/07	DAW	DAW	PV18-6LFB .27 (6.86) DIM. "W" WAS .24 (6.10)	TR00223	LCA	TRO	<p>TINLEY PARK, ILLINOIS</p> <p>TERMO 2PC. CONTINUOUSLY MOLDED VINYL INSULATED, #22-18 BARREL, LOCKING FORKS</p>			
06	3/03	KJS	SKB	PV18-LFB "W" DIM. WAS .24(6.1) ADDED CP-862, CA9, CD9-1A	10690	SKB	TRO				
05	12/00	SAB	SKB	FILESPEC WAS N41072AA_PCD_04	8925	JAC	CCH				
04	2/97	JAMB		UPDATE NOTES, "W" DIM. ON PV18-6LFB WAS .27(6.9) ORIGINAL FILE SPEC WAS NPC_A41072_03.	5571						
REV	DATE	BY	CHK	DESCRIPTION	ECN	CUST	PM	DRAWN BY DSM	CHK'D FS	SCALE NONE	DRAWING NO. A41072