

THIS DRAWING IS UNPUBLISHED. RELEASED FOR PUBLICATION
 © COPYRIGHT BY TYCO ELECTRONICS CORPORATION. ALL RIGHTS RESERVED.

LOC	DIST	REVISIONS					
AF	50	P	LTR	DESCRIPTION	DATE	DWN	APVD
			A3	REVISED PER ECR-06-022030	21SEP06	HMR	DD

- 1 CONTINUOUS STRIP ON REELS.
- 2 CRIMP WIDTH: .160 F TYPE.
 CRIMP HEIGHT ($\pm .002$) = (TOTAL CMA + 25,181) / 272,727
 GENERAL APPLICATOR GUIDELINES MUST BE FOLLOWED
 AS SPECIFIED IN CATALOG # 82221.

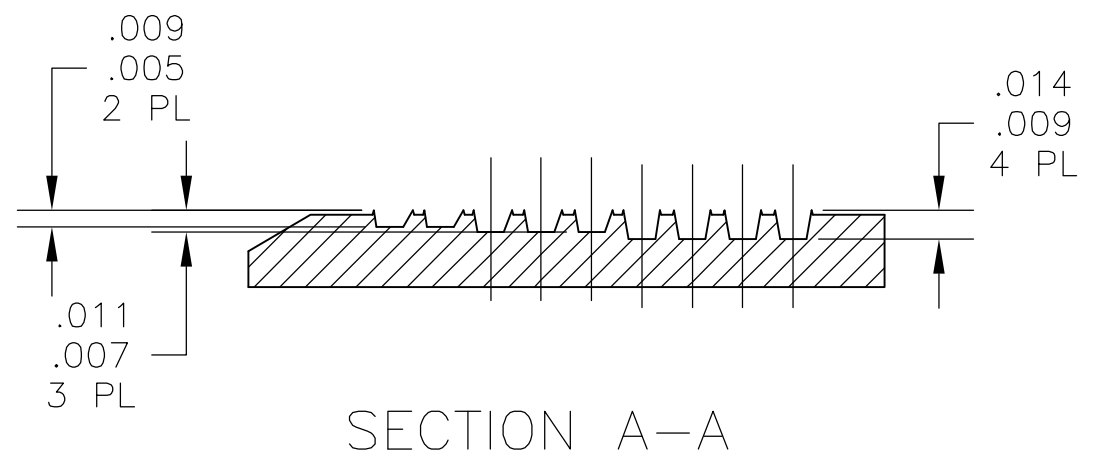
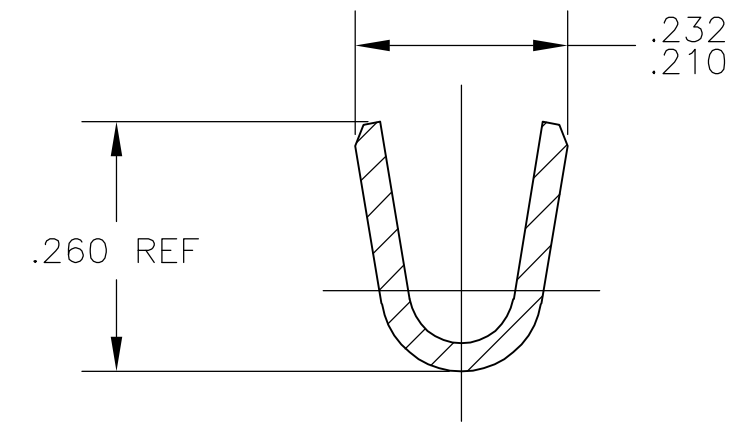
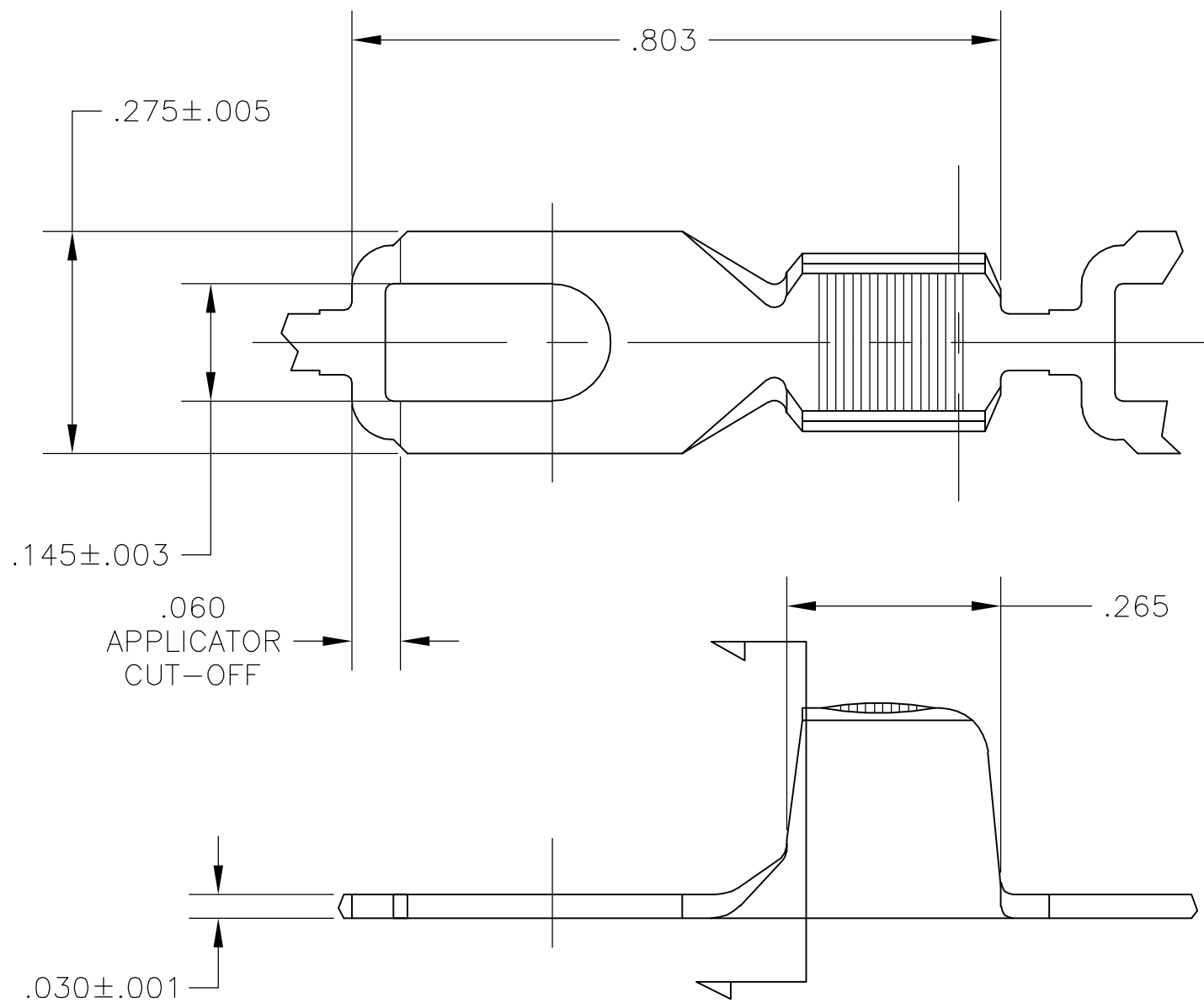

THIS DRAWING IS A CONTROLLED DOCUMENT.		DWN	JR RUTH	15SEP05
DIMENSIONS: INCHES		CHK	D.F. DECKER	15SEP05
TOLERANCES UNLESS OTHERWISE SPECIFIED:		APVD	D.F. DECKER	15SEP05
0 PLC	± -	PRODUCT SPEC	-	
1 PLC	± -	APPLICATION SPEC	-	
2 PLC	± -	WEIGHT	-	
3 PLC	± .010	CUSTOMER DRAWING	-	
4 PLC	± -	SCALE	5:1	
ANGLES	± -	SHEET	1 OF 1	
MATERIAL	082 BRASS	FINISH	.000150 MIN TIN	
RESTRICTED TO		REV	A3	

7000-13000		1742348-1	
WIRE RANGE		PART NUMBER	
Tyco Electronics Corporation Harrisburg, PA 17105-3608			
NAME SPADE, AMPLIVAR, 9 SERRATIONS, 6 STUD SIZE			
SIZE	CAGE CODE	DRAWING NO	RESTRICTED TO
A3	00779	C-1742348	-