

SPECIFICATION

SPEC. No. A-Mega-a

D A T E : 2015 Apr.

To

Non-Controlled Copy

CUSTOMER'S PRODUCT NAME

TDK PRODUCT NAME

MULTILAYER CERAMIC CHIP CAPACITORS
CKG Series / Automotive Grade
MEGACAP Type

Please return this specification to TDK representatives.

If orders are placed without returned specification, please allow us to judge that specification is accepted by your side.

RECEIPT CONFIRMATION

DATE: YEAR MONTH DAY

TDK Corporation
Sales
Electronic Components
Sales & Marketing Group

TDK-EPC Corporation
Engineering
Ceramic Capacitors Business Group

APPROVED	Person in charge

APPROVED	CHECKED	Person in charge

1. SCOPE

This specification is applicable to chip type multilayer ceramic capacitors with a priority over the other relevant specifications.

Production places defined in this specification shall be TDK-EPC Corporation Japan, TDK (Suzhou) Co., Ltd and TDK Components U.S.A. Inc.

EXPLANATORY NOTE:

This specification warrants the quality of the ceramic chip capacitors. The chips should be evaluated or confirmed a state of mounted on your product.

If the use of the chips goes beyond the bounds of the specification, we can not afford to guarantee.

2. CODE CONSTRUCTION

(Example)

Catalog Number :	<u>CKG32K</u>	<u>X7R</u>	<u>1E</u>	<u>106</u>	<u>K</u>	<u>335</u>	<u>A</u>	<u>J</u>
(Web)	<u>CKG45N</u>	<u>X7R</u>	<u>1C</u>	<u>226</u>	<u>M</u>	<u>500</u>	<u>J</u>	<u>J</u>
	(1)	(2)	(3)	(4)	(5)	(6)	(7)	(8)
Item Description :	<u>CKG32K</u>	<u>X7R</u>	<u>1E</u>	<u>106</u>	<u>K</u>	<u>I</u>	<u>xxxx</u>	
	<u>CKG45N</u>	<u>X7R</u>	<u>1C</u>	<u>226</u>	<u>M</u>	<u>I</u>	<u>xxxx</u>	
	(1)	(2)	(3)	(4)	(5)	(9)	(10)	

(1) Type

Single type
CKG**K: 1 chip capacitor.

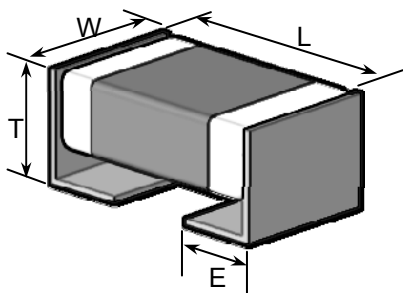

Stacked type
CKG**N: 2 chip capacitors.

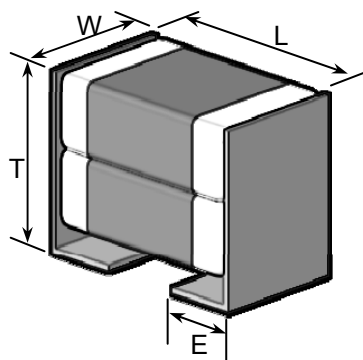

Please refer to product list for the dimension of each product.

(2) Temperature Characteristics (Details are shown in table 1 No.6 at page 3)

(3) Rated Voltage

Symbol	Rated Voltage
2 J	DC 630 V
2 W	DC 450 V
2 E	DC 250 V
2 A	DC 100 V
1 H	DC 50 V
1 E	DC 25 V
1 C	DC 16 V

(4) Rated Capacitance

Stated in three digits and in units of pico farads (pF).

The first and Second digits identify the first and second significant figures of the capacitance, the third digit identifies the multiplier.

R is designated for a decimal point.

Example 106 → 10,000,000pF

226 → 22,000,000pF

(5) Capacitance tolerance

Symbol	Tolerance
K ^{*1}	± 10 %
M	± 20 %(standard)

*1 As for CKG**K type with 10uF under, applied to K and M tolerance.

(6) Thickness code (Only Catalog Number)

(7) Package code (Only Catalog Number)

(8) Special code (Only Catalog Number)

(9) Packaging (Only Item Description)

Symbol	Packaging
T	Taping

(10) Internal code (Only Item Description)

3. OPERATING TEMPERATURE RANGE

T.C.	Min. operating Temperature	Max. operating Temperature	Reference Temperature
X5R	-55°C	85°C	25°C
X7R, X7S, X7T	-55°C	125°C	25°C

4. STORING CONDITION AND TERM

5 to 40°C at 20 to 70%RH

6 months Max.

5. INDUSTRIAL WASTE DISPOSAL

Dispose this product as industrial waste in accordance with the Industrial Waste Law.

6. PERFORMANCE

table 1

No.	Item	Performance	Test or inspection method															
1	External Appearance	No defects which may affect performance.	Inspect with magnifying glass (3×)															
2	Insulation Resistance	500MΩ·μF min. (As for the capacitors of rated voltage 16V DC, 100MΩ·μF min.,) whichever smaller.	Apply rated voltage for 60s. As for the rated voltage 630V DC, apply 500V DC.															
3	Voltage Proof	Withstand test voltage without insulation breakdown or other damage.	<table border="1"> <thead> <tr> <th>Rated voltage</th> <th>Apply voltage</th> </tr> </thead> <tbody> <tr> <td>100V and under</td> <td>2.5 × rated voltage</td> </tr> <tr> <td>Over 100V</td> <td>1.5 × rated voltage</td> </tr> </tbody> </table> <p>Above DC voltage shall be applied for 1 to 5s. Charge / discharge current shall not exceed 50mA.</p>	Rated voltage	Apply voltage	100V and under	2.5 × rated voltage	Over 100V	1.5 × rated voltage									
Rated voltage	Apply voltage																	
100V and under	2.5 × rated voltage																	
Over 100V	1.5 × rated voltage																	
4	Capacitance	Within the specified tolerance.	<table border="1"> <thead> <tr> <th>Rated Capacitance</th> <th>Measuring frequency</th> <th>Measuring voltage</th> </tr> </thead> <tbody> <tr> <td>10uF and under</td> <td>1kHz±10%</td> <td>1.0±0.2Vrms.</td> </tr> <tr> <td>Over 10uF</td> <td>120Hz±20%</td> <td>0.5±0.2Vrms.</td> </tr> </tbody> </table>	Rated Capacitance	Measuring frequency	Measuring voltage	10uF and under	1kHz±10%	1.0±0.2Vrms.	Over 10uF	120Hz±20%	0.5±0.2Vrms.						
Rated Capacitance	Measuring frequency	Measuring voltage																
10uF and under	1kHz±10%	1.0±0.2Vrms.																
Over 10uF	120Hz±20%	0.5±0.2Vrms.																
5	Dissipation Factor	<table border="1"> <thead> <tr> <th>T.C.</th> <th>D.F.</th> </tr> </thead> <tbody> <tr> <td>X5R</td> <td>0.03 max.</td> </tr> <tr> <td>X7R</td> <td>0.05 max.</td> </tr> <tr> <td>X7S</td> <td>0.075 max.</td> </tr> <tr> <td>X7T</td> <td>0.10 max.</td> </tr> </tbody> </table>	T.C.	D.F.	X5R	0.03 max.	X7R	0.05 max.	X7S	0.075 max.	X7T	0.10 max.	<p>See No.4 in this table for measuring condition.</p> <p>For information which product has which Dissipation Factor, please contact with our sales representative.</p>					
T.C.	D.F.																	
X5R	0.03 max.																	
X7R	0.05 max.																	
X7S	0.075 max.																	
X7T	0.10 max.																	
6	Temperature Characteristics of Capacitance	<p>Capacitance Change (%)</p> <table border="1"> <thead> <tr> <th>No voltage applied</th> </tr> </thead> <tbody> <tr> <td>X5R : ± 15</td> </tr> <tr> <td>X7R : ±15</td> </tr> <tr> <td>X7S : ±22</td> </tr> <tr> <td>X7T : +22 -33</td> </tr> </tbody> </table>	No voltage applied	X5R : ± 15	X7R : ±15	X7S : ±22	X7T : +22 -33	<p>Capacitance shall be measured by the steps shown in the following table after thermal equilibrium is obtained for each step. ΔC be calculated ref. STEP3 reading</p> <table border="1"> <thead> <tr> <th>Step</th> <th>Temperature(°C)</th> </tr> </thead> <tbody> <tr> <td>1</td> <td>Reference temp. ± 2</td> </tr> <tr> <td>2</td> <td>Min. operating temp. ± 2</td> </tr> <tr> <td>3</td> <td>Reference temp. ± 2</td> </tr> <tr> <td>4</td> <td>Max. operating temp. ± 2</td> </tr> </tbody> </table>	Step	Temperature(°C)	1	Reference temp. ± 2	2	Min. operating temp. ± 2	3	Reference temp. ± 2	4	Max. operating temp. ± 2
No voltage applied																		
X5R : ± 15																		
X7R : ±15																		
X7S : ±22																		
X7T : +22 -33																		
Step	Temperature(°C)																	
1	Reference temp. ± 2																	
2	Min. operating temp. ± 2																	
3	Reference temp. ± 2																	
4	Max. operating temp. ± 2																	

(continued)

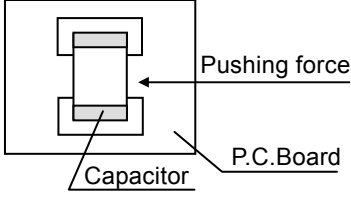
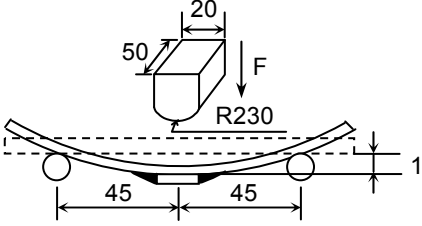
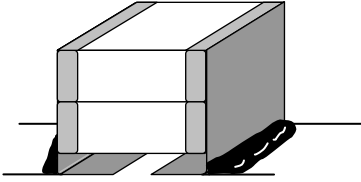
No.	Item	Performance	Test or inspection method
7	Robustness of Terminations	No sign of termination coming off, breakage of ceramic, or other abnormal signs.	Reflow solder the capacitors on a P.C.Board shown in Appendix 1 and apply a pushing force of 5N with 10 ± 1 s.  <p>The diagram shows a rectangular capacitor mounted on a P.C. Board. A horizontal arrow labeled 'Pushing force' points to the right against the capacitor. Labels 'Capacitor' and 'P.C.Board' are present.</p>
8	Bending	No mechanical damage.	Reflow solder the capacitors on a P.C.Board shown in Appendix 2 and bend it for 1mm.  <p>The diagram shows a P.C. Board bent into a curve. A capacitor is mounted on the board. A downward force 'F' is applied to the capacitor. Dimensions include a 20mm width for the capacitor, a 50mm length for the board section, a 45mm distance from the center to the ends, and a 1mm bend height. A radius of R230 is indicated for the board's curvature. The unit is mm.</p> <p>(Unit : mm)</p>
9	Solderability	Both end faces and the contact areas shall be covered with a smooth and bright solder coating with no more than a small amount of scattered imperfections such as pinholes or un-wetted or de-wetted areas. These imperfections shall not be concentrated in one area.  <p>The diagram shows a 3D perspective of a capacitor with a thick, dark solder coating on its end faces and the contact areas where it meets the board.</p>	Reflow solder the capacitors on a P.C. Board shown in Appendix 1. Solder : H63A (JIS Z 3282) Flux : Isopropyl alcohol (JIS K 8839) Rosin(JIS K 5902) 25% solid solution.

(continued)

No.	Item		Performance	Test or inspection method															
10	Temperature Cycle	External appearance	No mechanical damage.	<p>Reflow solder the capacitors on a P.C.Board shown in Appendix 1 before testing.</p> <p>Expose the capacitors in the condition step1 through step 4 and repeat 100 times consecutively.</p> <p>Leave the capacitors in ambient condition for 24±2h before measurement.</p> <table border="1"> <thead> <tr> <th>Step</th> <th>Temperature(°C)</th> <th>Time (min.)</th> </tr> </thead> <tbody> <tr> <td>1</td> <td>Min. operating temp. ± 3</td> <td>30 ± 3</td> </tr> <tr> <td>2</td> <td>Reference temp. ± 2</td> <td>2 - 5</td> </tr> <tr> <td>3</td> <td>Max. operating temp. ± 2</td> <td>30 ± 2</td> </tr> <tr> <td>4</td> <td>Reference temp. ± 2</td> <td>2 - 5</td> </tr> </tbody> </table>	Step	Temperature(°C)	Time (min.)	1	Min. operating temp. ± 3	30 ± 3	2	Reference temp. ± 2	2 - 5	3	Max. operating temp. ± 2	30 ± 2	4	Reference temp. ± 2	2 - 5
		Step	Temperature(°C)		Time (min.)														
		1	Min. operating temp. ± 3		30 ± 3														
		2	Reference temp. ± 2		2 - 5														
		3	Max. operating temp. ± 2		30 ± 2														
4	Reference temp. ± 2	2 - 5																	
Capacitance	<table border="1"> <thead> <tr> <th>Characteristics</th> <th>Change from the value before test</th> </tr> </thead> <tbody> <tr> <td>X5R X7R X7S X7T</td> <td>± 7.5 %</td> </tr> </tbody> </table>	Characteristics	Change from the value before test	X5R X7R X7S X7T	± 7.5 %														
Characteristics	Change from the value before test																		
X5R X7R X7S X7T	± 7.5 %																		
D.F.	Meet the initial spec.																		
Insulation Resistance	Meet the initial spec.																		
Voltage proof	No insulation breakdown or other damage.																		
11	Moisture Resistance	External appearance	No mechanical damage.	<p>Reflow solder the capacitors on a P.C.Board shown in Appendix 1 before testing.</p> <p>Apply the rated voltage at temperature 40±2°C and 90 to 95%RH for 500 +24,0h.</p> <p>Charge/discharge current shall not exceed 50mA.</p> <p>Leave the capacitors in ambient condition for 24±2h before measurement.</p> <p>Voltage conditioning Voltage treat the capacitors under testing temperature and voltage for 1 hour.</p> <p>Leave the capacitors in ambient condition for 24±2h before measurement.</p> <p>Use this measurement for initial value.</p>															
		Capacitance	<table border="1"> <thead> <tr> <th>Characteristics</th> <th>Change from the value before test</th> </tr> </thead> <tbody> <tr> <td>X5R X7R X7S X7T</td> <td>± 12.5 %</td> </tr> </tbody> </table>		Characteristics	Change from the value before test	X5R X7R X7S X7T	± 12.5 %											
		Characteristics	Change from the value before test																
		X5R X7R X7S X7T	± 12.5 %																
D.F.	Characteristics X5R/X7R/X7S/X7T : 200% of initial spec. max.																		
Insulation Resistance	25MΩ·μF min. (As for the capacitors of rated voltage 16V DC, 5MΩ·μF min.,).																		

(continued)

No.	Item	Performance	Test or inspection method																				
12	Life	<table border="1"> <tr> <td data-bbox="360 215 533 309">External appearance</td> <td colspan="2" data-bbox="533 215 970 309">No mechanical damage.</td> </tr> <tr> <td data-bbox="360 309 533 539">Capacitance</td> <td data-bbox="533 309 740 539"> <table border="1"> <tr> <th data-bbox="533 309 740 398">Characteristics</th> <th data-bbox="740 309 970 398">Change from the value before test</th> </tr> <tr> <td data-bbox="533 398 740 539">X5R X7R X7S X7T</td> <td data-bbox="740 398 970 539">± 15 %</td> </tr> </table> </td> <td data-bbox="970 309 1476 1570" rowspan="4"> <p data-bbox="978 226 1452 331">Reflow solder the capacitors on a P.C.Board shown in Appendix 1 before testing.</p> <p data-bbox="978 387 1445 492">Below the voltage shall be applied at Maximum operating temperature ±2°C for 1,000 +48, 0h.</p> <table border="1" data-bbox="1011 510 1410 748"> <tr><td data-bbox="1011 510 1410 562">Applied voltage</td></tr> <tr><td data-bbox="1011 562 1410 613">Rated voltage x2</td></tr> <tr><td data-bbox="1011 613 1410 665">Rated voltage x1.5</td></tr> <tr><td data-bbox="1011 665 1410 716">Rated voltage x1.2</td></tr> <tr><td data-bbox="1011 716 1410 748">Rated voltage x1</td></tr> </table> <p data-bbox="978 786 1437 891">For information which product has which applied voltage, please contact with our sales representative.</p> <p data-bbox="978 947 1404 1008">Charge/discharge current shall not exceed 50mA.</p> <p data-bbox="978 1064 1369 1169">Leave the capacitors in ambient condition for 24±2h before measurement.</p> <p data-bbox="978 1265 1430 1411">Voltage conditioning Voltage treat the capacitors under testing temperature and voltage for 1 hour.</p> <p data-bbox="978 1426 1369 1532">Leave the capacitors in ambient condition for 24±2h before measurement.</p> <p data-bbox="978 1547 1445 1570">Use this measurement for initial value.</p> </td> </tr> <tr> <td data-bbox="360 539 533 689">D.F.</td> <td colspan="2" data-bbox="533 539 970 689"> Characteristics X5R/X7R/X7S/X7T : 200% of initial spec. max. </td> </tr> <tr> <td data-bbox="360 689 533 1570">Insulation Resistance</td> <td colspan="2" data-bbox="533 689 970 1570"> 50MΩ·μF min. (As for the capacitors of rated voltage 16V DC, 10MΩ·μF min..) </td> </tr> </table>	External appearance	No mechanical damage.		Capacitance	<table border="1"> <tr> <th data-bbox="533 309 740 398">Characteristics</th> <th data-bbox="740 309 970 398">Change from the value before test</th> </tr> <tr> <td data-bbox="533 398 740 539">X5R X7R X7S X7T</td> <td data-bbox="740 398 970 539">± 15 %</td> </tr> </table>	Characteristics	Change from the value before test	X5R X7R X7S X7T	± 15 %	<p data-bbox="978 226 1452 331">Reflow solder the capacitors on a P.C.Board shown in Appendix 1 before testing.</p> <p data-bbox="978 387 1445 492">Below the voltage shall be applied at Maximum operating temperature ±2°C for 1,000 +48, 0h.</p> <table border="1" data-bbox="1011 510 1410 748"> <tr><td data-bbox="1011 510 1410 562">Applied voltage</td></tr> <tr><td data-bbox="1011 562 1410 613">Rated voltage x2</td></tr> <tr><td data-bbox="1011 613 1410 665">Rated voltage x1.5</td></tr> <tr><td data-bbox="1011 665 1410 716">Rated voltage x1.2</td></tr> <tr><td data-bbox="1011 716 1410 748">Rated voltage x1</td></tr> </table> <p data-bbox="978 786 1437 891">For information which product has which applied voltage, please contact with our sales representative.</p> <p data-bbox="978 947 1404 1008">Charge/discharge current shall not exceed 50mA.</p> <p data-bbox="978 1064 1369 1169">Leave the capacitors in ambient condition for 24±2h before measurement.</p> <p data-bbox="978 1265 1430 1411">Voltage conditioning Voltage treat the capacitors under testing temperature and voltage for 1 hour.</p> <p data-bbox="978 1426 1369 1532">Leave the capacitors in ambient condition for 24±2h before measurement.</p> <p data-bbox="978 1547 1445 1570">Use this measurement for initial value.</p>	Applied voltage	Rated voltage x2	Rated voltage x1.5	Rated voltage x1.2	Rated voltage x1	D.F.	Characteristics X5R/X7R/X7S/X7T : 200% of initial spec. max.		Insulation Resistance	50MΩ·μF min. (As for the capacitors of rated voltage 16V DC, 10MΩ·μF min..)	
External appearance	No mechanical damage.																						
Capacitance	<table border="1"> <tr> <th data-bbox="533 309 740 398">Characteristics</th> <th data-bbox="740 309 970 398">Change from the value before test</th> </tr> <tr> <td data-bbox="533 398 740 539">X5R X7R X7S X7T</td> <td data-bbox="740 398 970 539">± 15 %</td> </tr> </table>	Characteristics	Change from the value before test	X5R X7R X7S X7T	± 15 %	<p data-bbox="978 226 1452 331">Reflow solder the capacitors on a P.C.Board shown in Appendix 1 before testing.</p> <p data-bbox="978 387 1445 492">Below the voltage shall be applied at Maximum operating temperature ±2°C for 1,000 +48, 0h.</p> <table border="1" data-bbox="1011 510 1410 748"> <tr><td data-bbox="1011 510 1410 562">Applied voltage</td></tr> <tr><td data-bbox="1011 562 1410 613">Rated voltage x2</td></tr> <tr><td data-bbox="1011 613 1410 665">Rated voltage x1.5</td></tr> <tr><td data-bbox="1011 665 1410 716">Rated voltage x1.2</td></tr> <tr><td data-bbox="1011 716 1410 748">Rated voltage x1</td></tr> </table> <p data-bbox="978 786 1437 891">For information which product has which applied voltage, please contact with our sales representative.</p> <p data-bbox="978 947 1404 1008">Charge/discharge current shall not exceed 50mA.</p> <p data-bbox="978 1064 1369 1169">Leave the capacitors in ambient condition for 24±2h before measurement.</p> <p data-bbox="978 1265 1430 1411">Voltage conditioning Voltage treat the capacitors under testing temperature and voltage for 1 hour.</p> <p data-bbox="978 1426 1369 1532">Leave the capacitors in ambient condition for 24±2h before measurement.</p> <p data-bbox="978 1547 1445 1570">Use this measurement for initial value.</p>	Applied voltage	Rated voltage x2	Rated voltage x1.5	Rated voltage x1.2	Rated voltage x1												
Characteristics	Change from the value before test																						
X5R X7R X7S X7T	± 15 %																						
Applied voltage																							
Rated voltage x2																							
Rated voltage x1.5																							
Rated voltage x1.2																							
Rated voltage x1																							
D.F.	Characteristics X5R/X7R/X7S/X7T : 200% of initial spec. max.																						
Insulation Resistance	50MΩ·μF min. (As for the capacitors of rated voltage 16V DC, 10MΩ·μF min..)																						

*As for the initial measurement of capacitors on number 6 and 10, leave capacitors at 150 –10,0°C for 1 hour and measure the value after leaving capacitors for 24±2h in ambient condition.

Appendix - 1

P.C. Board for reliability

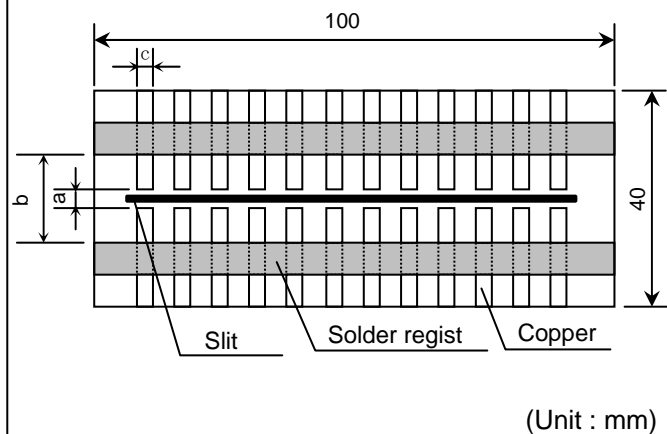

Appendix - 2

P.C. Board for bending

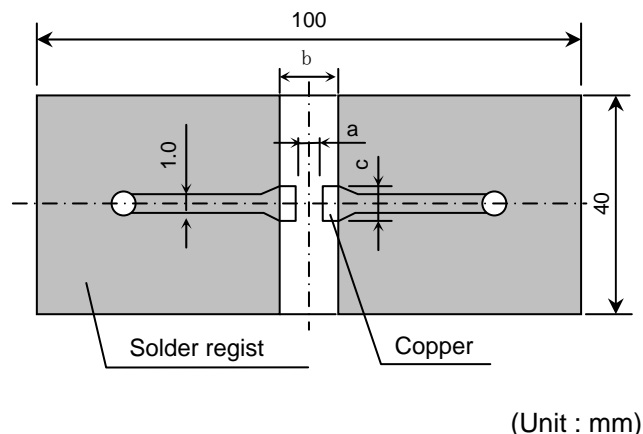



(Unit : mm)

Type	Dimensions		
TDK(EIA style)	a	b	c
CKG32K	2.2	5.0	2.9
CKG45K	3.5	6.1	2.9
CKG57K	4.1	7.6	4.7
CKG45N	3.5	6.1	2.9
CKG57N	4.1	7.6	4.7

1. Material : Glass Epoxy(As per JIS C6484 GE4)

2. Thickness : 1.6mm

 Copper(Thickness:0.035mm)
 Solder resist

7. INSIDE STRUCTURE AND MATERIAL

CKGK : Single**
(1 chip capacitor.)

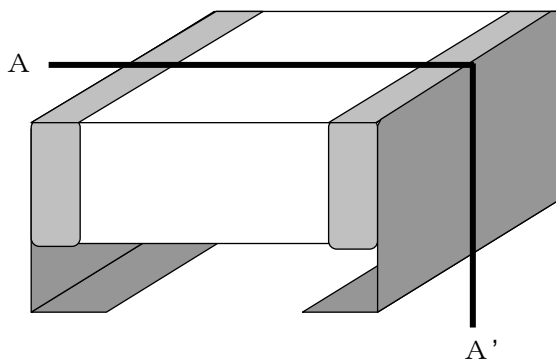

CKGN : Double**
(2 chip capacitors.)

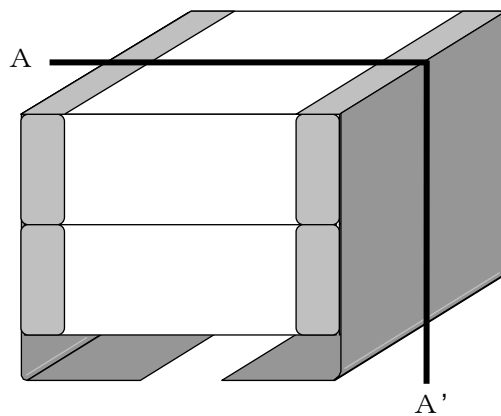

A - A'

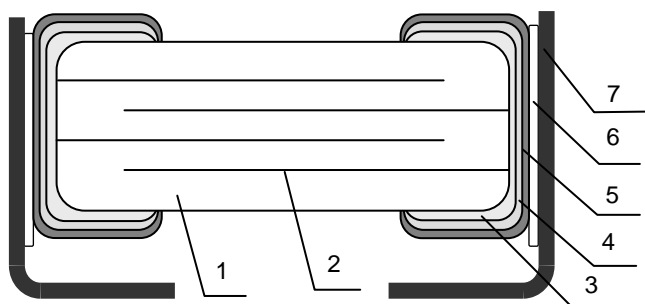

A - A'

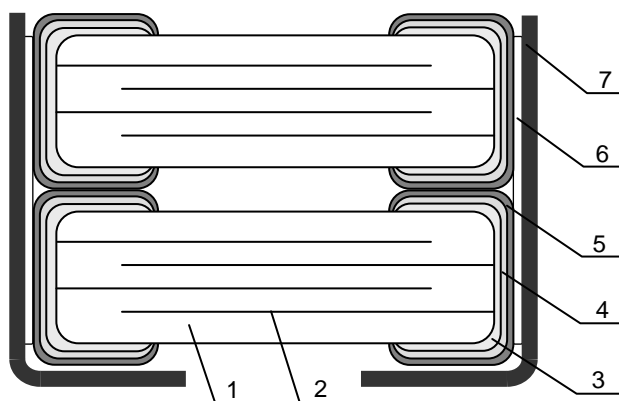

No.	NAME	MATERIAL
1	Dielectric	BaTiO ₃
2	Electrode	Nickel (Ni)
3	Termination	Copper (Cu)
4		Nickel (Ni)
5		Tin (Sn)
6	Metal cap joint	High temp solder
7	Metal cap	42 Alloy

8. RECOMMENDATION

It is recommended to provide a slit (about 1mm wide) in the board under the components to improve washing Flux.

And please make sure to dry detergent up completely before.

9. SOLDERING CONDITION

Reflow soldering only.

“Metal cap joint” is high temperature solder, but it may be melted under high temperature (more than 250°C).

Please keep a soldering temperature of 250°C or less and refer to “CAUTION” on page 15-17 in detail.

10. Caution

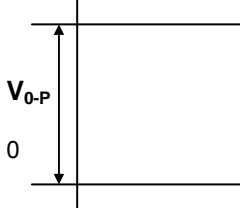
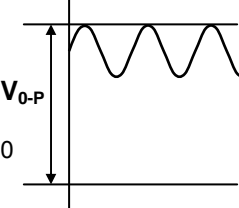
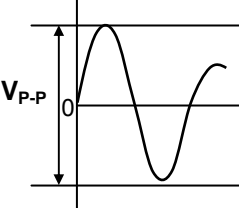
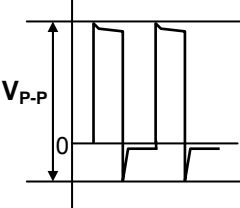
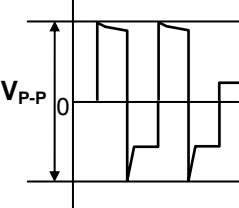
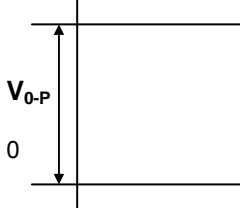
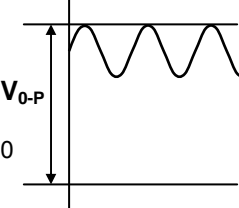
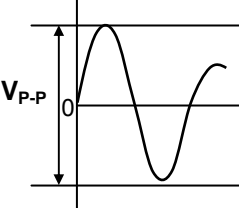
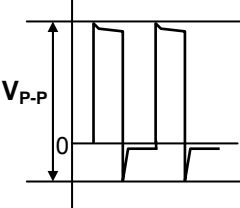
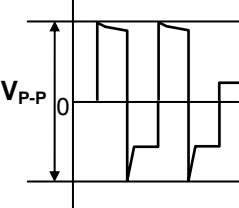
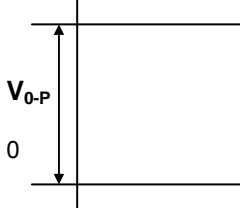
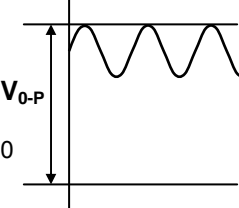
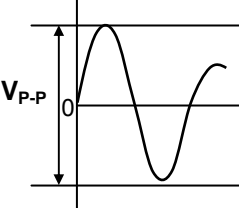
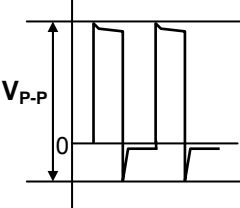
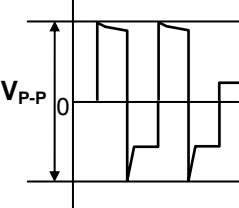
No.	Process	Condition														
1	Operating Condition (Storage, Transportation)	<p>1-1. Storage</p> <ol style="list-style-type: none"> The capacitors must be stored in an ambient temperature of 5 to 40°C with a relative humidity of 20 to 70%RH. The products should be used within 6 months upon receipt. The capacitors must be operated and stored in an environment free of dew condensation and these gases such as Hydrogen Sulphide, Hydrogen Sulphate, Chlorine, Ammonia and sulfur. Avoid storing in sun light and falling of dew. Do not use capacitors under high humidity and high and low atmospheric pressure which may affect capacitors reliability. Capacitors should be tested for the solderability when they are stored for long time. <p>1-2. Handling in transportation In case of the transportation of the capacitors, the performance of the capacitors may be deteriorated depending on the transportation condition. (Refer to JEITA RCR-2335B 9.2 Handling in transportation)</p>														
2	Circuit design ⚠ Caution	<p>2-1. Operating temperature Operating temperature should be followed strictly within this specification, especially be careful with maximum temperature.</p> <ol style="list-style-type: none"> Do not use capacitors above the maximum allowable operating temperature. Surface temperature including self heating should be below maximum operating temperature. (Due to dielectric loss, capacitors will heat itself when AC is applied. Especially at high frequencies around its SRF, the heat might be so extreme that it may damage itself or the product mounted on. Please design the circuit so that the maximum temperature of the capacitors including the self heating to be below the maximum allowable operating temperature. Temperature rise at capacitor surface shall be below 20°C) The electrical characteristics of the capacitors will vary depending on the temperature. The capacitors should be selected and designed in taking the temperature into consideration. <p>2-2. Operating voltage</p> <ol style="list-style-type: none"> Operating voltage across the terminals should be below the rated voltage. When AC and DC are super imposed, V_{0-P} must be below the rated voltage. _____ (1) and (2) AC or pulse with overshooting, V_{P-P} must be below the rated voltage. _____ (3), (4) and (5) When the voltage is started to apply to the circuit or it is stopped applying, the irregular voltage may be generated for a transit period because of resonance or switching. Be sure to use the capacitors within rated voltage containing these Irregular voltage. <table border="1" data-bbox="472 1447 1445 1720"> <thead> <tr> <th data-bbox="472 1447 660 1491">Voltage</th> <th data-bbox="660 1447 922 1491">(1) DC voltage</th> <th data-bbox="922 1447 1184 1491">(2) DC+AC voltage</th> <th data-bbox="1184 1447 1445 1491">(3) AC voltage</th> </tr> </thead> <tbody> <tr> <td data-bbox="472 1491 660 1720">Positional Measurement (Rated voltage)</td> <td data-bbox="660 1491 922 1720">  </td> <td data-bbox="922 1491 1184 1720">  </td> <td data-bbox="1184 1491 1445 1720">  </td> </tr> </tbody> </table> <table border="1" data-bbox="472 1749 1445 2016"> <thead> <tr> <th data-bbox="472 1749 660 1794">Voltage</th> <th data-bbox="660 1749 922 1794">(4) Pulse voltage (A)</th> <th data-bbox="922 1749 1445 1794">(5) Pulse voltage (B)</th> </tr> </thead> <tbody> <tr> <td data-bbox="472 1794 660 2016">Positional Measurement (Rated voltage)</td> <td data-bbox="660 1794 922 2016">  </td> <td data-bbox="922 1794 1445 2016">  </td> </tr> </tbody> </table>	Voltage	(1) DC voltage	(2) DC+AC voltage	(3) AC voltage	Positional Measurement (Rated voltage)				Voltage	(4) Pulse voltage (A)	(5) Pulse voltage (B)	Positional Measurement (Rated voltage)		
Voltage	(1) DC voltage	(2) DC+AC voltage	(3) AC voltage													
Positional Measurement (Rated voltage)																
Voltage	(4) Pulse voltage (A)	(5) Pulse voltage (B)														
Positional Measurement (Rated voltage)																

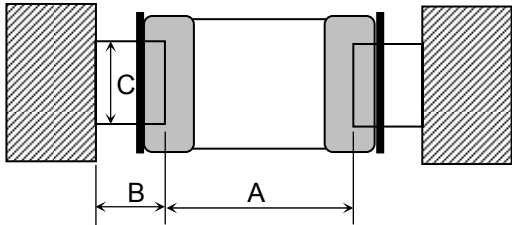
No.	Process	Condition																
2	Circuit design ⚠ Caution	2) Even below the rated voltage, if repetitive high frequency AC or pulse is applied, the reliability of the capacitors may be reduced. 3) The effective capacitance will vary depending on applied DC and AC voltages. The capacitors should be selected and designed in taking the voltages into consideration. 2-3. Frequency When the capacitors (Class 2) are used in AC and/or pulse voltages, the capacitors may vibrate themselves and generate audible sound.																
3	Designing P.C.board	The amount of solder at the terminations has a direct effect on the reliability of the capacitors. 1) The greater the amount of solder, the higher the stress on the chip capacitors, and the more likely that it will break. When designing a P.C.board, determine the shape and size of the solder lands to have proper amount of solder on the terminations. 2) Avoid using common solder land for multiple terminations and provide individual solder land for each terminations. 3) Size and recommended land dimensions. <div style="text-align: center;">  </div> <div style="text-align: right; margin-right: 100px;">(mm)</div> <table border="1" style="margin-left: auto; margin-right: auto;"> <thead> <tr> <th>Type Symbol</th> <th>CKG32K</th> <th>CKG45K CKG45N</th> <th>CKG57K CKG57N</th> </tr> </thead> <tbody> <tr> <td>A</td> <td>2.0 – 2.2</td> <td>3.3 – 3.7</td> <td>3.9 – 4.3</td> </tr> <tr> <td>B</td> <td>1.1 - 1.3</td> <td>1.2 - 1.5</td> <td>1.5 – 2.0</td> </tr> <tr> <td>C</td> <td>2.3 – 2.5</td> <td>2.7 – 3.2</td> <td>4.5 – 5.0</td> </tr> </tbody> </table>	Type Symbol	CKG32K	CKG45K CKG45N	CKG57K CKG57N	A	2.0 – 2.2	3.3 – 3.7	3.9 – 4.3	B	1.1 - 1.3	1.2 - 1.5	1.5 – 2.0	C	2.3 – 2.5	2.7 – 3.2	4.5 – 5.0
Type Symbol	CKG32K	CKG45K CKG45N	CKG57K CKG57N															
A	2.0 – 2.2	3.3 – 3.7	3.9 – 4.3															
B	1.1 - 1.3	1.2 - 1.5	1.5 – 2.0															
C	2.3 – 2.5	2.7 – 3.2	4.5 – 5.0															

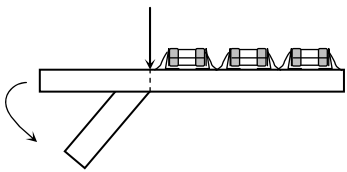
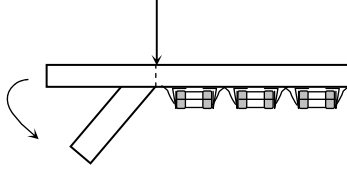
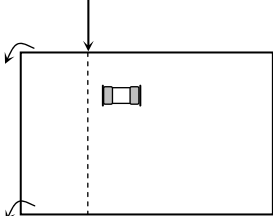
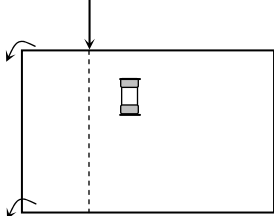
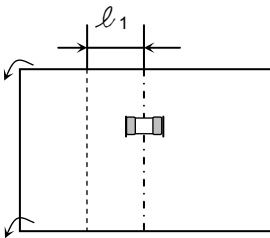
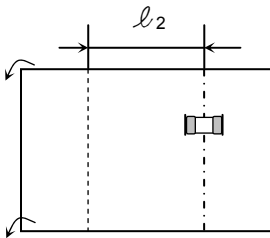
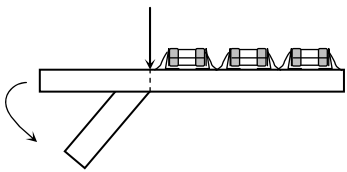
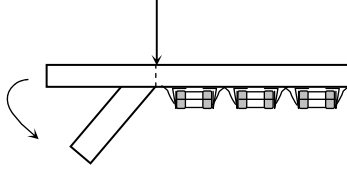
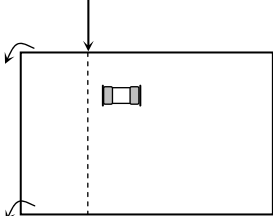
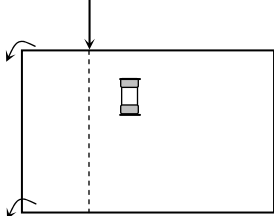
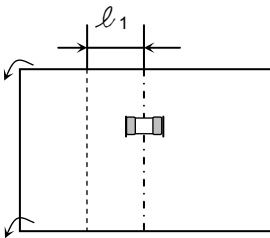
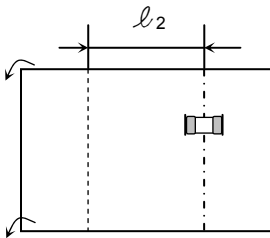
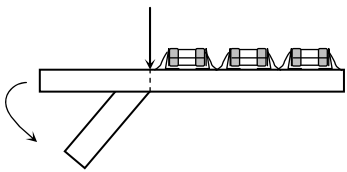
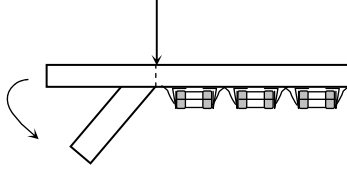
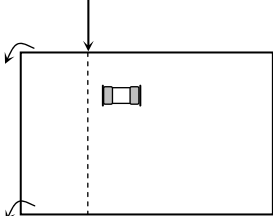
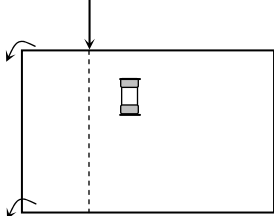
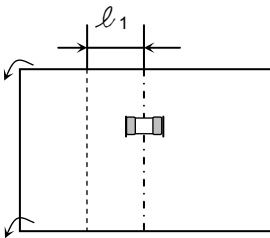
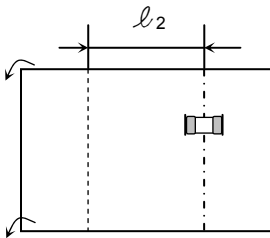
No.	Process	Condition												
3	Designing P.C.board	<p data-bbox="437 188 1098 219">4) Recommended chip capacitors layout is as following.</p> <table border="1" data-bbox="475 255 1430 1675"> <thead> <tr> <th data-bbox="475 255 660 331"></th> <th data-bbox="660 255 1043 331">Disadvantage against bending stress</th> <th data-bbox="1043 255 1430 331">Advantage against bending stress</th> </tr> </thead> <tbody> <tr> <td data-bbox="475 331 660 748">Mounting face</td> <td data-bbox="660 331 1043 748"> <p data-bbox="746 376 954 407">Perforation or slit</p>  <p data-bbox="699 636 944 703">Break P.C.board with mounted side up.</p> </td> <td data-bbox="1043 331 1430 748"> <p data-bbox="1136 376 1343 407">Perforation or slit</p>  <p data-bbox="1091 636 1340 703">Break P.C.board with mounted side down.</p> </td> </tr> <tr> <td data-bbox="475 748 660 1196">Chip arrangement (Direction)</td> <td data-bbox="660 748 1043 1196"> <p data-bbox="746 869 954 900">Perforation or slit</p>  </td> <td data-bbox="1043 748 1430 1196"> <p data-bbox="1136 869 1343 900">Perforation or slit</p>  </td> </tr> <tr> <td data-bbox="475 1196 660 1675">Distance from slit</td> <td data-bbox="660 1196 1043 1675"> <p data-bbox="673 1205 1005 1236">Closer to slit is higher stress</p>  <p data-bbox="880 1576 1008 1608">$(l_1 < l_2)$</p> </td> <td data-bbox="1043 1196 1430 1675"> <p data-bbox="1056 1205 1388 1236">Away from slit is less stress</p>  <p data-bbox="1264 1576 1391 1608">$(l_1 < l_2)$</p> </td> </tr> </tbody> </table>		Disadvantage against bending stress	Advantage against bending stress	Mounting face	<p data-bbox="746 376 954 407">Perforation or slit</p>  <p data-bbox="699 636 944 703">Break P.C.board with mounted side up.</p>	<p data-bbox="1136 376 1343 407">Perforation or slit</p>  <p data-bbox="1091 636 1340 703">Break P.C.board with mounted side down.</p>	Chip arrangement (Direction)	<p data-bbox="746 869 954 900">Perforation or slit</p> 	<p data-bbox="1136 869 1343 900">Perforation or slit</p> 	Distance from slit	<p data-bbox="673 1205 1005 1236">Closer to slit is higher stress</p>  <p data-bbox="880 1576 1008 1608">$(l_1 < l_2)$</p>	<p data-bbox="1056 1205 1388 1236">Away from slit is less stress</p>  <p data-bbox="1264 1576 1391 1608">$(l_1 < l_2)$</p>
	Disadvantage against bending stress	Advantage against bending stress												
Mounting face	<p data-bbox="746 376 954 407">Perforation or slit</p>  <p data-bbox="699 636 944 703">Break P.C.board with mounted side up.</p>	<p data-bbox="1136 376 1343 407">Perforation or slit</p>  <p data-bbox="1091 636 1340 703">Break P.C.board with mounted side down.</p>												
Chip arrangement (Direction)	<p data-bbox="746 869 954 900">Perforation or slit</p> 	<p data-bbox="1136 869 1343 900">Perforation or slit</p> 												
Distance from slit	<p data-bbox="673 1205 1005 1236">Closer to slit is higher stress</p>  <p data-bbox="880 1576 1008 1608">$(l_1 < l_2)$</p>	<p data-bbox="1056 1205 1388 1236">Away from slit is less stress</p>  <p data-bbox="1264 1576 1391 1608">$(l_1 < l_2)$</p>												

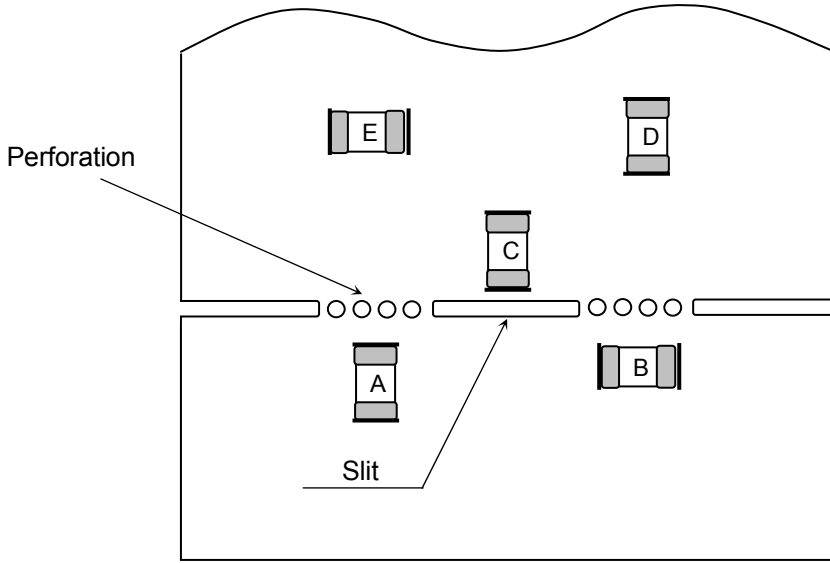
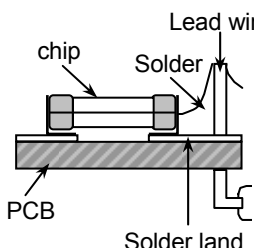
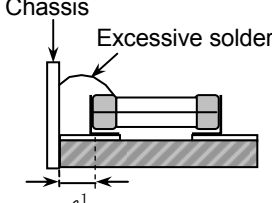
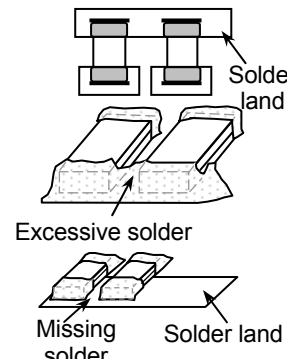
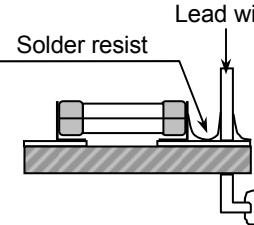
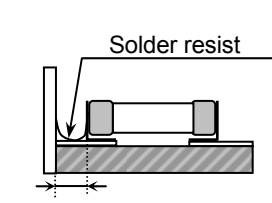
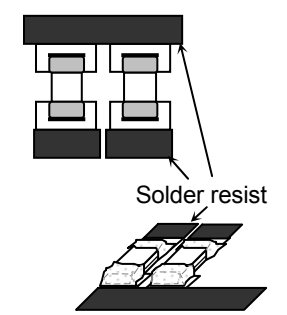
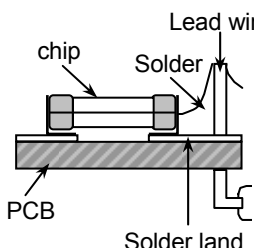
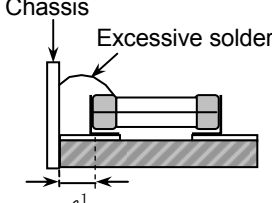
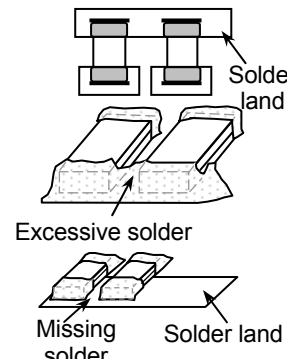
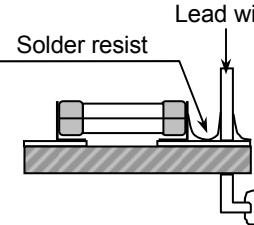
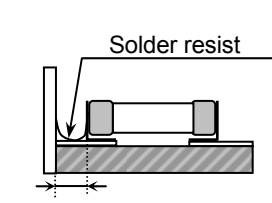
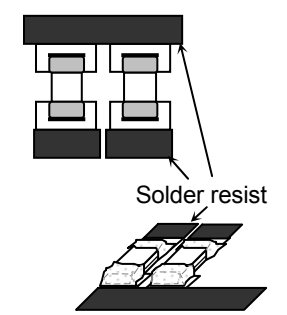
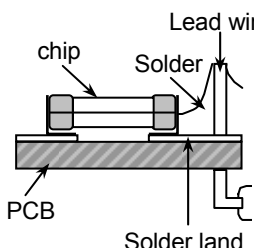
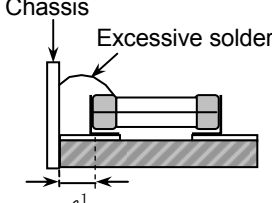
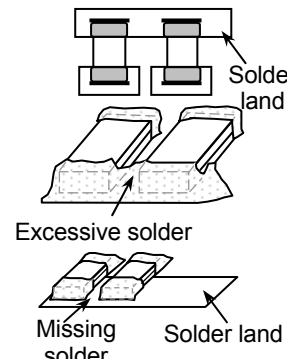
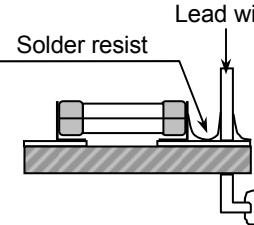
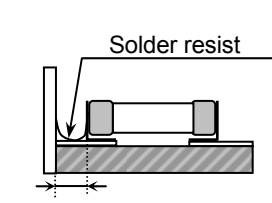
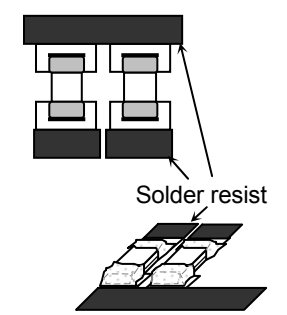
No.	Process	Condition												
3	Designing P.C.board	<p>5) Mechanical stress varies according to location of chip capacitors on the P.C.board.</p>  <p>The stress in capacitors is in the following order. $A > B = C > D > E$</p> <p>6) Layout recommendation</p> <table border="1"> <thead> <tr> <th data-bbox="379 1008 539 1124">Example</th> <th data-bbox="539 1008 842 1124">Use of common solder land</th> <th data-bbox="842 1008 1152 1124">Soldering with chassis</th> <th data-bbox="1152 1008 1489 1124">Use of common solder land with other SMD</th> </tr> </thead> <tbody> <tr> <td data-bbox="379 1124 539 1523">Need to avoid</td> <td data-bbox="539 1124 842 1523">  </td> <td data-bbox="842 1124 1152 1523">  </td> <td data-bbox="1152 1124 1489 1523">  </td> </tr> <tr> <td data-bbox="379 1523 539 1937">Recommendation</td> <td data-bbox="539 1523 842 1937">  </td> <td data-bbox="842 1523 1152 1937">  <p>$l^2 > l^1$</p> </td> <td data-bbox="1152 1523 1489 1937">  </td> </tr> </tbody> </table>	Example	Use of common solder land	Soldering with chassis	Use of common solder land with other SMD	Need to avoid				Recommendation		 <p>$l^2 > l^1$</p>	
Example	Use of common solder land	Soldering with chassis	Use of common solder land with other SMD											
Need to avoid														
Recommendation		 <p>$l^2 > l^1$</p>												

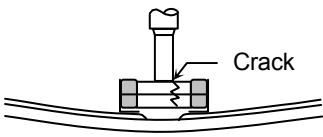
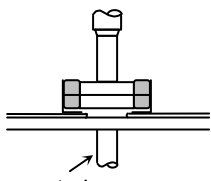
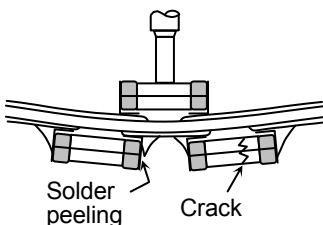
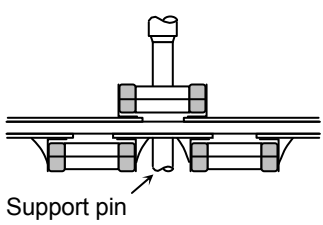
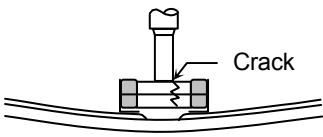
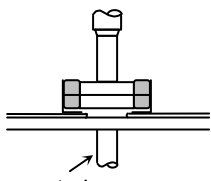
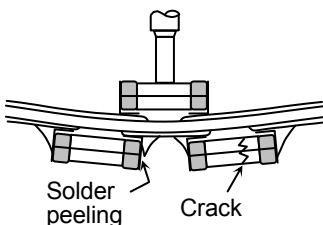
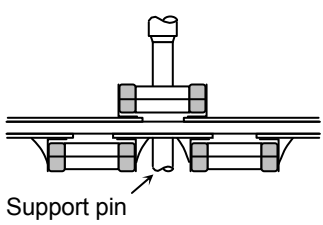
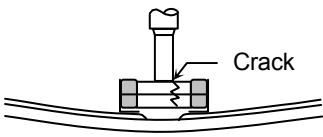
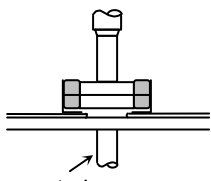
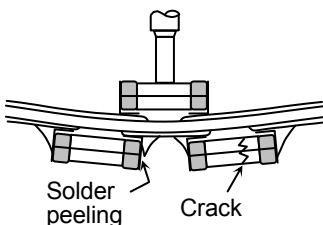
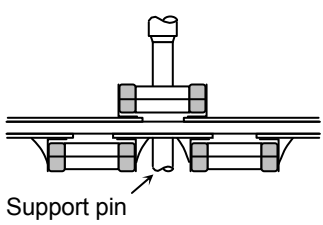
No.	Process	Condition									
4	Mounting	<p>4-1. Stress from mounting head</p> <p>If the mounting head is adjusted too low, it may induce excessive stress in the chip capacitors to result in cracking. Please take following precautions.</p> <ol style="list-style-type: none"> 1) Adjust the bottom dead center of the mounting head to reach on the P.C.board surface and not press it. 2) Adjust the mounting head pressure to be 1 to 3N of static weight. 3) To minimize the impact energy from mounting head, it is important to provide support from the bottom side of the P.C.board. See following examples. <table border="1" data-bbox="481 600 1433 1160"> <thead> <tr> <th data-bbox="481 600 665 651"></th> <th data-bbox="665 600 1061 651">Not recommended</th> <th data-bbox="1061 600 1433 651">Recommended</th> </tr> </thead> <tbody> <tr> <td data-bbox="481 651 665 898">Single sided mounting</td> <td data-bbox="665 651 1061 898">  </td> <td data-bbox="1061 651 1433 898">  </td> </tr> <tr> <td data-bbox="481 898 665 1160">Double-sides mounting</td> <td data-bbox="665 898 1061 1160">  </td> <td data-bbox="1061 898 1433 1160">  </td> </tr> </tbody> </table> <p>When the centering jaw is worn out, it may give mechanical impact on the capacitors to cause crack. Please control the close up dimension of the centering jaw and provide sufficient preventive maintenance and replacement of it.</p>		Not recommended	Recommended	Single sided mounting			Double-sides mounting		
	Not recommended	Recommended									
Single sided mounting											
Double-sides mounting											

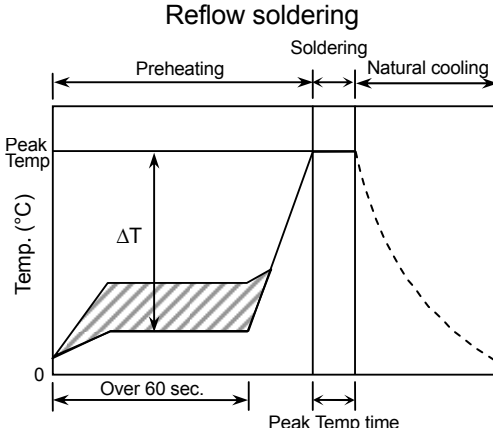
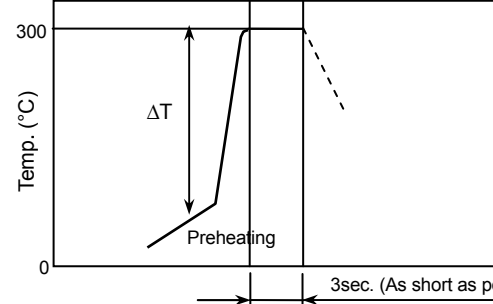
No.	Process	Condition														
5	Soldering	<p>5-1. Flux selection</p> <p>Although highly-activated flux gives better solderability, substances which increase activity may also degrade the insulation of the chip capacitors. To avoid such degradation, it is recommended following.</p> <ol style="list-style-type: none"> 1) It is recommended to use a mildly activated rosin flux (less than 0.1wt% chlorine). Strong flux is not recommended. 2) Excessive flux must be avoided. Please provide proper amount of flux. 3) When water-soluble flux is used, enough washing is necessary. <p>5-2. Recommended soldering profile by various methods</p> <ol style="list-style-type: none"> 1) Soldering condition (Pre heating temperature, soldering temperature and these times) is limited to reflow soldering method which is stipulated on the specification. 2) Chips should be mounted, shortly after a solder is on a P.C.Board. 3) Enough preheating is necessary to avoid chip cracking. Small temperature differences is less heat stress. 4) Temperature differences (ΔT) <div style="text-align: center;"> <p>Reflow soldering</p>  </div> <div style="text-align: center; margin-top: 20px;"> <p>Manual soldering (Solder iron)</p>  </div> <p style="text-align: right; margin-right: 100px;">* Temperature of metal cap surface should not exceed 250°C.</p> <p>5-3. Recommended soldering peak temp and peak temp duration</p> <table border="1" style="width: 100%; border-collapse: collapse;"> <thead> <tr> <th data-bbox="517 1668 762 1720" rowspan="2">Temp./Duration</th> <th colspan="2" data-bbox="762 1668 1220 1720">Reflow soldering</th> </tr> <tr> <th data-bbox="762 1720 995 1780">Peak temp(°C)</th> <th data-bbox="995 1720 1220 1780">Duration(sec.)</th> </tr> </thead> <tbody> <tr> <td data-bbox="517 1780 762 1841">Solder</td> <td></td> <td></td> </tr> <tr> <td data-bbox="517 1841 762 1901">Sn-Pb Solder</td> <td data-bbox="762 1841 995 1901">230 max.</td> <td data-bbox="995 1841 1220 1901">20 max.</td> </tr> <tr> <td data-bbox="517 1901 762 1962">Lead Free Solder</td> <td data-bbox="762 1901 995 1962">250 max.</td> <td data-bbox="995 1901 1220 1962">10 max.</td> </tr> </tbody> </table> <p>Recommended solder compositions</p> <p>Sn-37Pb (Sn-Pb solder)</p> <p>Sn-3.0Ag-0.5Cu (Lead Free Solder)</p>	Temp./Duration	Reflow soldering		Peak temp(°C)	Duration(sec.)	Solder			Sn-Pb Solder	230 max.	20 max.	Lead Free Solder	250 max.	10 max.
Temp./Duration	Reflow soldering															
	Peak temp(°C)	Duration(sec.)														
Solder																
Sn-Pb Solder	230 max.	20 max.														
Lead Free Solder	250 max.	10 max.														

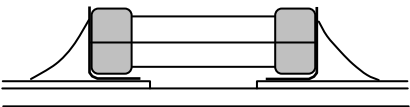
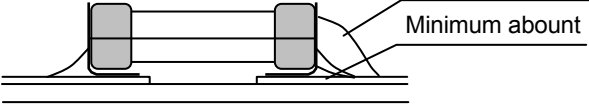
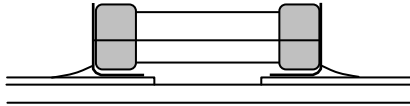
No.	Process	Condition														
5	Soldering	<p>5-4. Avoiding thermal shock</p> <p>1) Preheating condition</p> <table border="1" data-bbox="528 264 967 421"> <thead> <tr> <th>Soldering</th> <th>Temp. (°C)</th> </tr> </thead> <tbody> <tr> <td>Reflow soldering</td> <td>$\Delta T \leq 130$</td> </tr> <tr> <td>Manual soldering</td> <td>$\Delta T \leq 130$</td> </tr> </tbody> </table> <p>2) Cooling condition Natural cooling using air is recommended. If the chips are dipped into a solvent for cleaning, the temperature difference (ΔT) must be less than 100°C.</p> <p>5-5. Amount of solder</p> <p>Excessive solder will induce higher tensile force in chip capacitors when temperature changes and it may result in chip cracking. In sufficient solder may detach the capacitors from the P.C.board.</p> <div style="display: flex; justify-content: space-between; align-items: flex-start;"> <div style="width: 30%;"> <p>Excessive solder</p> </div> <div style="width: 30%; text-align: center;">  </div> <div style="width: 30%;"> <p>Higher tensile force in chip capacitors to cause crack</p> </div> </div> <hr/> <div style="display: flex; justify-content: space-between; align-items: flex-start;"> <div style="width: 30%;"> <p>Adequate</p> </div> <div style="width: 30%; text-align: center;">  </div> <div style="width: 30%;"></div> </div> <hr/> <div style="display: flex; justify-content: space-between; align-items: flex-start;"> <div style="width: 30%;"> <p>Insufficient solder</p> </div> <div style="width: 30%; text-align: center;">  </div> <div style="width: 30%;"> <p>Low robustness may cause contact failure or chip capacitors come off the P.C.board.</p> </div> </div> <hr/> <p>5-6. Solder repair by solder iron</p> <p>1) Selection of the soldering iron tip</p> <p>Tip temperature of solder iron varies by its type, P.C.board material and solder land size. The higher the tip temperature, the quicker the operation. However, heat shock may cause a crack in the chip capacitors. Please make sure the tip temp. before soldering and keep the peak temp and time in accordance with following recommended condition. (Please preheat the chip capacitors with the condition in 5-4 to avoid the thermal shock.)</p> <p>Recommended solder iron condition (Sn-Pb Solder and Lead Free Solder)</p> <table border="1" data-bbox="528 1570 1366 1682"> <thead> <tr> <th>Temp. (°C)</th> <th>Duration (sec.)</th> <th>Wattage (W)</th> <th>Shape (mm)</th> </tr> </thead> <tbody> <tr> <td>300 max.</td> <td>3 max.</td> <td>20 max.</td> <td>Ø 3.0 max.</td> </tr> </tbody> </table> <p>2) Direct contact of the soldering iron with ceramic dielectric of chip capacitors may cause crack. Do not touch the ceramic dielectric and the terminations by solder iron.</p>	Soldering	Temp. (°C)	Reflow soldering	$\Delta T \leq 130$	Manual soldering	$\Delta T \leq 130$	Temp. (°C)	Duration (sec.)	Wattage (W)	Shape (mm)	300 max.	3 max.	20 max.	Ø 3.0 max.
Soldering	Temp. (°C)															
Reflow soldering	$\Delta T \leq 130$															
Manual soldering	$\Delta T \leq 130$															
Temp. (°C)	Duration (sec.)	Wattage (W)	Shape (mm)													
300 max.	3 max.	20 max.	Ø 3.0 max.													

No.	Process	Condition
5	Soldering	<p>5-7. Sn-Zn solder Sn-Zn solder affects product reliability. Please contact TDK in advance when utilize Sn-Zn solder.</p> <p>5-8. Countermeasure for tombstone The misalignment between the mounted positions of the capacitors and the land patterns should be minimized. The tombstone phenomenon may occur especially the capacitors are mounted (in longitudinal direction) in the same direction of the reflow soldering. (Refer to JEITA RCR-2335B Annex 1 (Informative) Recommendations to prevent the tombstone phenomenon)</p>
6	Cleaning	<p>1) If an unsuitable cleaning fluid is used, flux residue or some foreign articles may stick to chip capacitors surface to deteriorate especially the insulation resistance.</p> <p>2) If cleaning condition is not suitable, it may damage the chip capacitors.</p> <p>2)-1. Insufficient washing</p> <p>(1) Terminal electrodes may corrode by Halogen in the flux.</p> <p>(2) Halogen in the flux may adhere on the surface of capacitors, and lower the insulation resistance.</p> <p>(3) Water soluble flux has higher tendency to have above mentioned problems (1) and (2).</p> <p>2)-2. Excessive washing</p> <p>When ultrasonic cleaning is used, excessively high ultrasonic energy output can affect the connection between the ceramic chip capacitor's body and the terminal electrode. To avoid this, following is the recommended condition.</p> <p style="text-align: center;">Power: 20 W/l max. Frequency: 40 kHz max. Washing time: 5 minutes max.</p> <p>2)-3. If the cleaning fluid is contaminated, density of Halogen increases, and it may bring the same result as insufficient cleaning.</p>
7	Coating and molding of the P.C.board	<p>1) When the P.C.board is coated, please verify the quality influence on the product.</p> <p>2) Please verify carefully that there is no harmful decomposing or reaction gas emission during curing which may damage the chip capacitors.</p> <p>3) Please verify the curing temperature.</p>

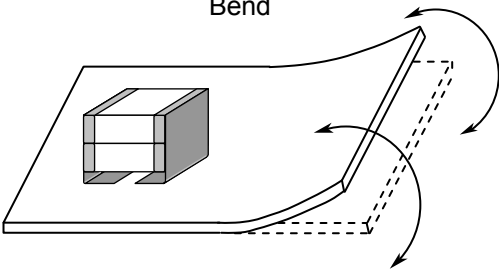
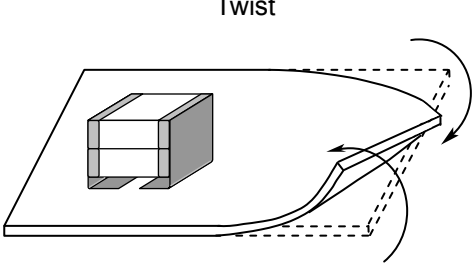
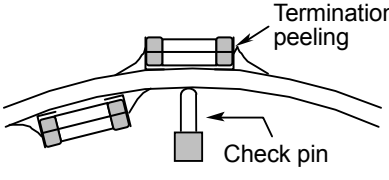
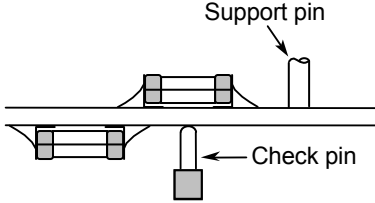
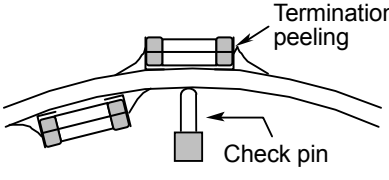
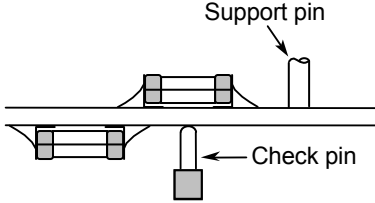
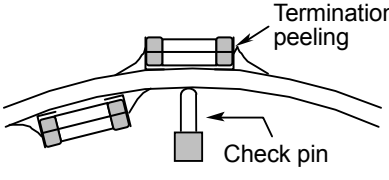
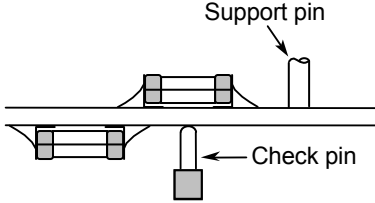
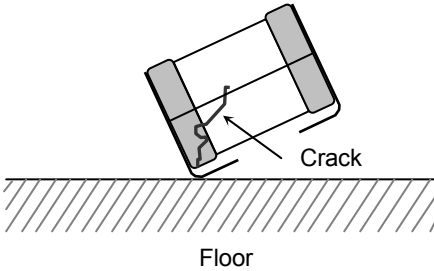
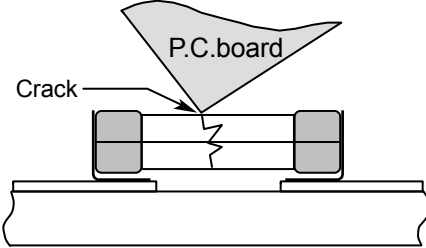
No.	Process	Condition						
8	Handling after chip mounted ⚠ Caution	<p>1) Please pay attention not to bend or distort the P.C.board after soldering in handling otherwise the chip capacitors may crack.</p> <div style="display: flex; justify-content: space-around; align-items: center;"> <div style="text-align: center;"> <p>Bend</p>  </div> <div style="text-align: center;"> <p>Twist</p>  </div> </div> <p>2) When functional check of the P.C.board is performed, check pin pressure tends to be adjusted higher for fear of loose contact. But if the pressure is excessive and bend the P.C.board, it may crack the chip capacitors or peel the terminations off. Please adjust the check pins not to bend the P.C.board.</p> <table border="1" style="width: 100%; border-collapse: collapse;"> <thead> <tr> <th data-bbox="491 779 628 837">Item</th> <th data-bbox="628 779 1046 837">Not recommended</th> <th data-bbox="1046 779 1449 837">Recommended</th> </tr> </thead> <tbody> <tr> <td data-bbox="491 837 628 1137" style="text-align: center; vertical-align: middle;">Board bending</td> <td data-bbox="628 837 1046 1137" style="text-align: center;">  </td> <td data-bbox="1046 837 1449 1137" style="text-align: center;">  </td> </tr> </tbody> </table>	Item	Not recommended	Recommended	Board bending		
Item	Not recommended	Recommended						
Board bending								
9	Handling of loose chip capacitors	<p>1) If dropped the chip capacitors may crack. Once dropped do not use it. Especially, the large case sized chip capacitors are tendency to have cracks easily, so please handle with care.</p> <div style="text-align: center;">  </div> <p>2) Piling the P.C.board after mounting for storage or handling, the corner of the P.C.board may hit the chip capacitors of another board to cause crack.</p> <div style="text-align: center;">  </div>						

No.	Process	Condition
10	Capacitance aging	The capacitors (Class 2) have aging in the capacitance. They may not be used in precision time constant circuit. In case of the time constant circuit, the evaluation should be done well.
11	Estimated life and estimated failure rate of capacitors	As per the estimated life and the estimated failure rate depend on the temperature and the voltage. This can be calculated by the equation described in JEITA RCR-2335B Annex 6 (Informative) Calculation of the estimated lifetime and the estimated failure rate (Voltage acceleration coefficient : 3 multiplication rule, Temperature acceleration coefficient : 10°C rule) The failure rate can be decreased by reducing the temperature and the voltage but they will not be guaranteed.
12	Others ⚠ Caution	<p>The products listed on this specification sheet are intended for use in general electronic equipment (AV equipment, telecommunications equipment, home appliances, amusement equipment, computer equipment, personal equipment, office equipment, measurement equipment, industrial robots) under a normal operation and use condition.</p> <p>The products are not designed or warranted to meet the requirements of the applications listed below, whose performance and/or quality require a more stringent level of safety or reliability, or whose failure, malfunction or trouble could cause serious damage to society, person or property. Please understand that we are not responsible for any damage or liability caused by use of the products in any of the applications below or for any other use exceeding the range or conditions set forth in this specification sheet. If you intend to use the products in the applications listed below or if you have special requirements exceeding the range or conditions set forth in this specification, please contact us.</p> <ul style="list-style-type: none"> (1) Aerospace/Aviation equipment (2) Transportation equipment (electric trains, ships, etc.) (3) Medical equipment (4) Power-generation control equipment (5) Atomic energy-related equipment (6) Seabed equipment (7) Transportation control equipment (8) Public information-processing equipment (9) Military equipment (10) Electric heating apparatus, burning equipment (11) Disaster prevention/crime prevention equipment (12) Safety equipment (13) Other applications that are not considered general-purpose applications <p>When designing your equipment even for general-purpose applications, you are kindly requested to take into consideration securing protection circuit/device or providing backup circuits in your equipment.</p>

11. Packaging label

Packaging shall be done to protect the components from the damage during transportation and storing, and a label which has the following information shall be attached.

- 1) Inspection No.
- 2) TDK P/N
- 3) Customer's P/N
- 4) Quantity

*Composition of Inspection No.

Example M 2 A - 00 - 000
 (a) (b) (c) (d) (e)

- a) Line code
- b) Last digit of the year
- c) Month and A for January and B for February and so on. (Skip I)
- d) Inspection Date of the month.
- e) Serial No. of the day

12. TAPE PACKAGING SPECIFICATION

1. CONSTRUCTION AND DIMENSION OF TAPING

1-1. Dimensions of carrier tape

Dimensions of paper tape shall be according to Appendix 3(CKG32K).

Dimensions of plastic tape shall be according to Appendix 4(CKG45K, CKG45N, CKG57K, CKG57N).

1-2. Bulk part and leader of taping

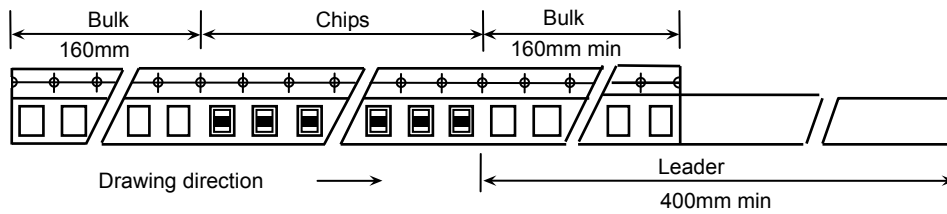

1-3. Dimensions of reel

Dimensions of $\varnothing 178$ reel shall be according to Appendix 5.

Dimensions of $\varnothing 330$ reel shall be according to Appendix 6.

1-4. Structure of taping

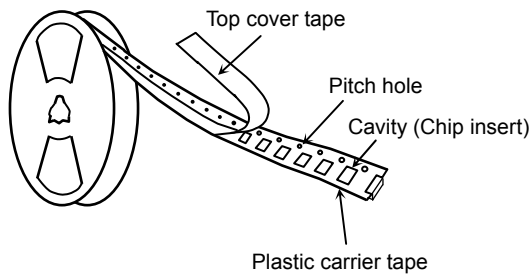

2. CHIP QUANTITY

Type	Taping Material	Chip quantity(pcs.)	
		$\varnothing 178$ mm reel	$\varnothing 330$ mm reel
CKG32K	plastic	1,000	4,000
CKG45K		————	1,000
CKG57K		————	1,000
CKG45N		————	1,000
CKG57N		————	1,000

3. PERFORMANCE SPECIFICATIONS

3-1. Fixing peeling strength (top tape)

0.05-0.7N. (See the following figure.)

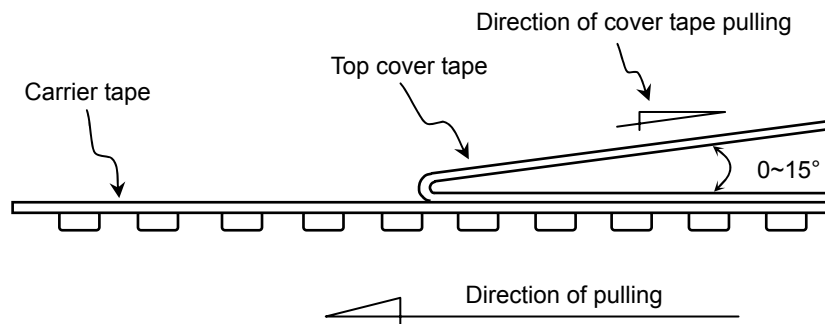

3-2. Carrier tape shall be flexible enough to be wound around a minimum radius of 30mm with components in tape.

3-3. The missing of components shall be less than 0.1%

3-4. Components shall not stick to fixing tape.

3-5. The fixing tapes shall not protrude beyond the edges of the carrier tape
not shall cover the sprocket holes.

Appendix 3

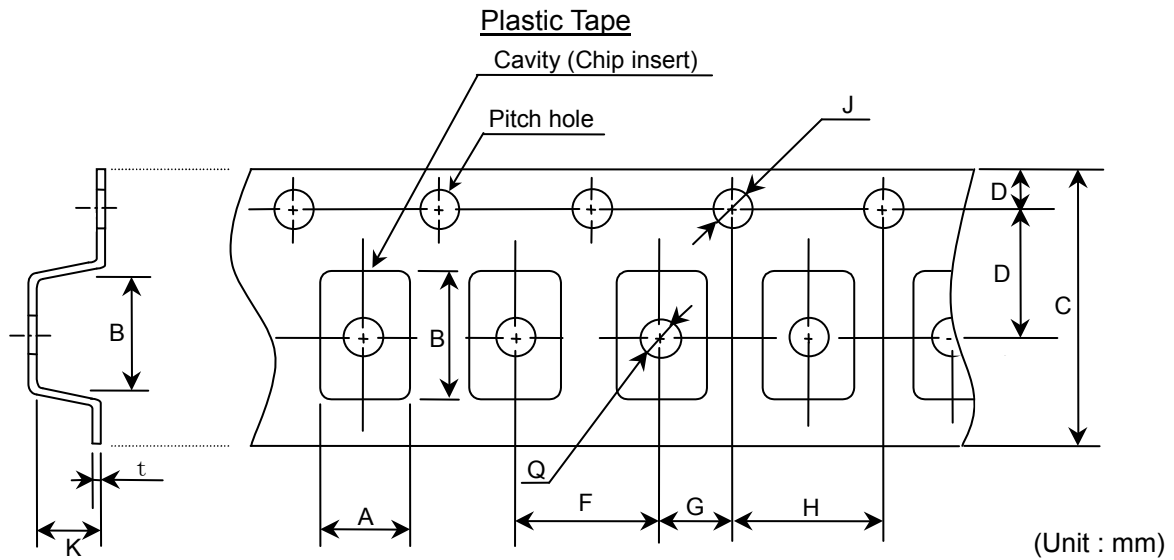

Symbol Type	A	B	C	D	E	F
CKG32K	(3.00)	(3.90)	12.0 ± 0.25	5.50 ± 0.05	1.75 ± 0.10	4.00 ± 0.10

Symbol Type	G	H	J	K	t	Q
CKG32K	2.00 ± 0.10	4.00 ± 0.10	∅ 1.5 ^{+0.10} ₀	3.75 max.	0.50 ± 0.05	∅ 1.65 ± 0.10

* The values in the parentheses () are for reference.

Appendix 4

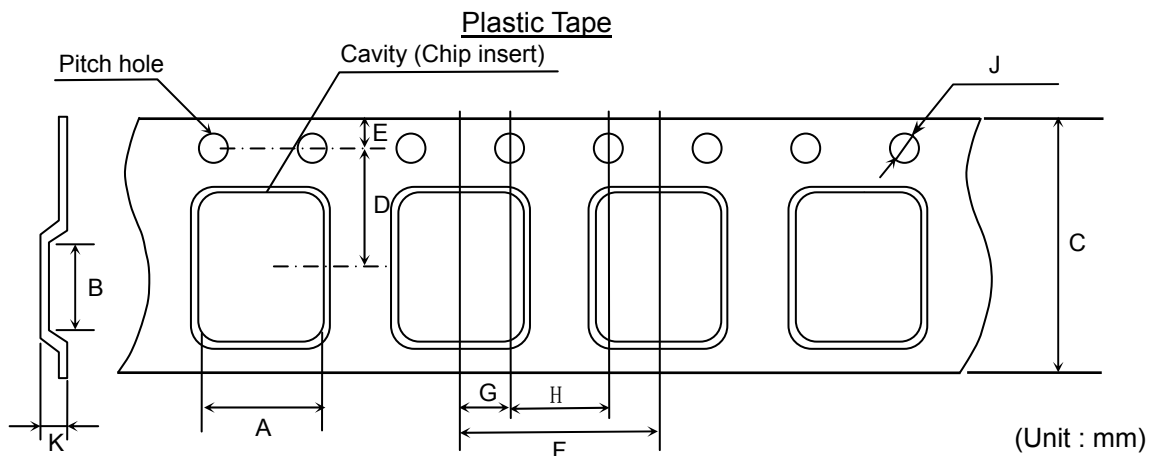

Symbol Type	A	B	C	D	E	F
CKG45K	(3.90)	(5.60)	12.0 ± 0.30	5.50 ± 0.10	1.75 ± 0.10	8.00 ± 0.10
CKG45N						
CKG57K	(5.60)	(6.60)	16.0 ± 0.30	7.50 ± 0.10	1.75 ± 0.10	8.00 ± 0.10
CKG57N						

Symbol Type	G	H	J	K
CKG45K	2.00 ± 0.10	4.00 ± 0.10	∅ 1.5 ^{+0.10} ₀	3.75 max.
CKG45N				6.15 max.
CKG57K	2.00 ± 0.10	4.00 ± 0.10	∅ 1.5 ^{+0.10} ₀	4.15 max.
CKG57N				6.15 max.

* The values in the parentheses () are for reference.

Appendix 5

(Material : Polystyrene)

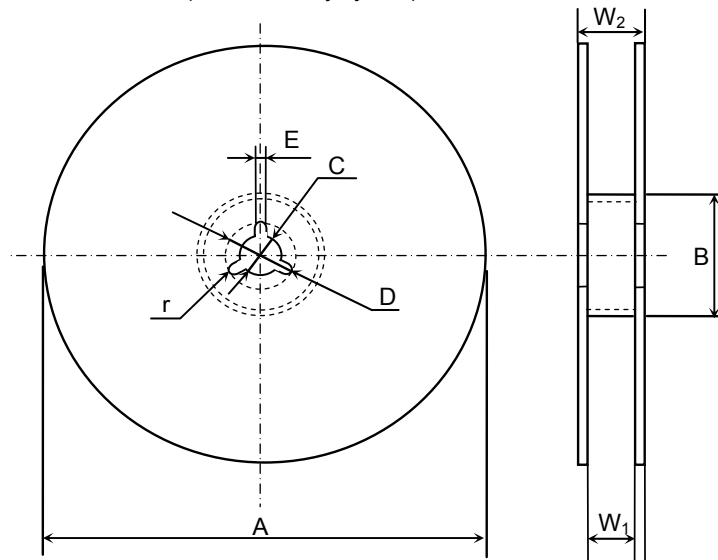

(Unit : mm)

Symbol Dimension	A	B	C	D	E	W ₁
CKG32	Ø178 ± 2.0	Ø60 ± 2.0	Ø13 ± 0.5	Ø21 ± 0.8	2.0 ± 0.5	13.0 ± 0.3

Symbol Dimension	W ₂	r
CKG32	17.0 ± 1.4	1.0

Appendix 6

(Material : Polystyrene)

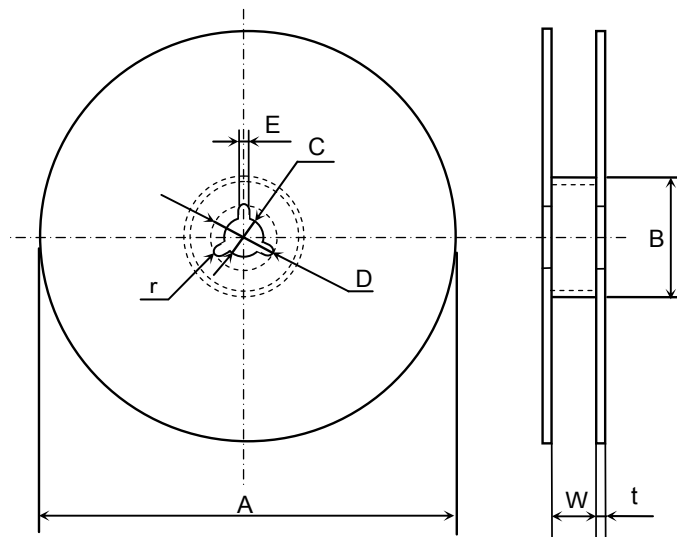

(Unit : mm)

Symbol Dimension	A	B	C	D	E	W
CKG32K	Ø382 max. (Nominal Ø330)	Ø50 min.	Ø13 ± 0.5	Ø21 ± 0.8	2.0 ± 0.5	14.0 ± 1.5
CKG45K, CKG45N						13.5 ± 1.5
CKG57K, CKG57N						17.5 ± 1.5

Symbol Dimension	t	r
CKG32	2.0 ± 0.5	1.0
CKG45K, CKG45N		
CKG57K, CKG57N		