

THIS DRAWING IS UNPUBLISHED. RELEASED FOR PUBLICATION, 19 .
 © COPYRIGHT 19 BY AMP INCORPORATED. ALL INTERNATIONAL RIGHTS RESERVED.

LOC		DIST		P		F		REVISIONS		DATE	APPD
G	14							ZONE	LTR	DESCRIPTION	
								C		REV PER 063A-0124-02	06MAR02 JS MS

METRIC
 DIMENSIONS LISTED IN mm [INCHES]

AMP WIRE RANGE	UL E13288 Listed
26-22 AWG STRANDED	NOT LISTED
SP LR7189 Certified	MILITARY P/N AND CLASS
NOT CERTIFIED	NOT APPLICABLE

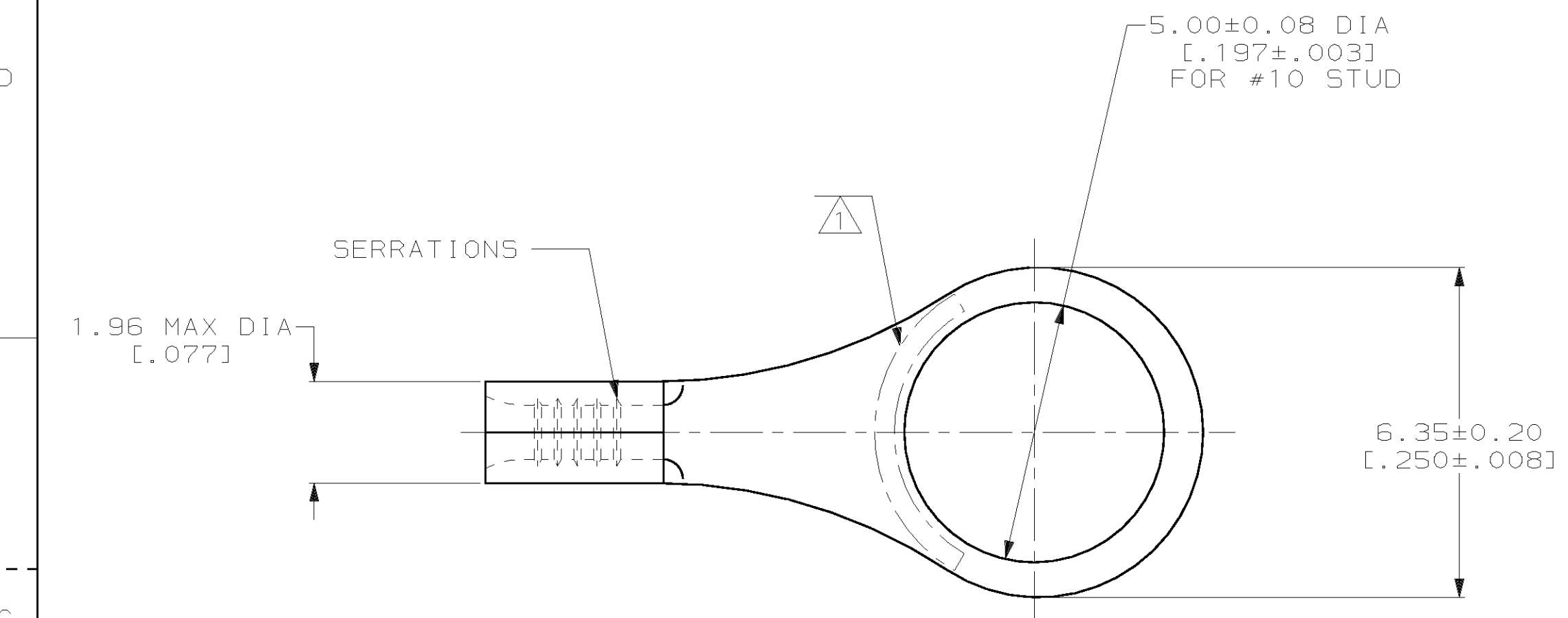

- ① STAMP AMP APPROX AS SHOWN
- ② 0.00254 [.000100] MIN TIN PER ASTM B-545
- ③ CLEANED, UNPLATED

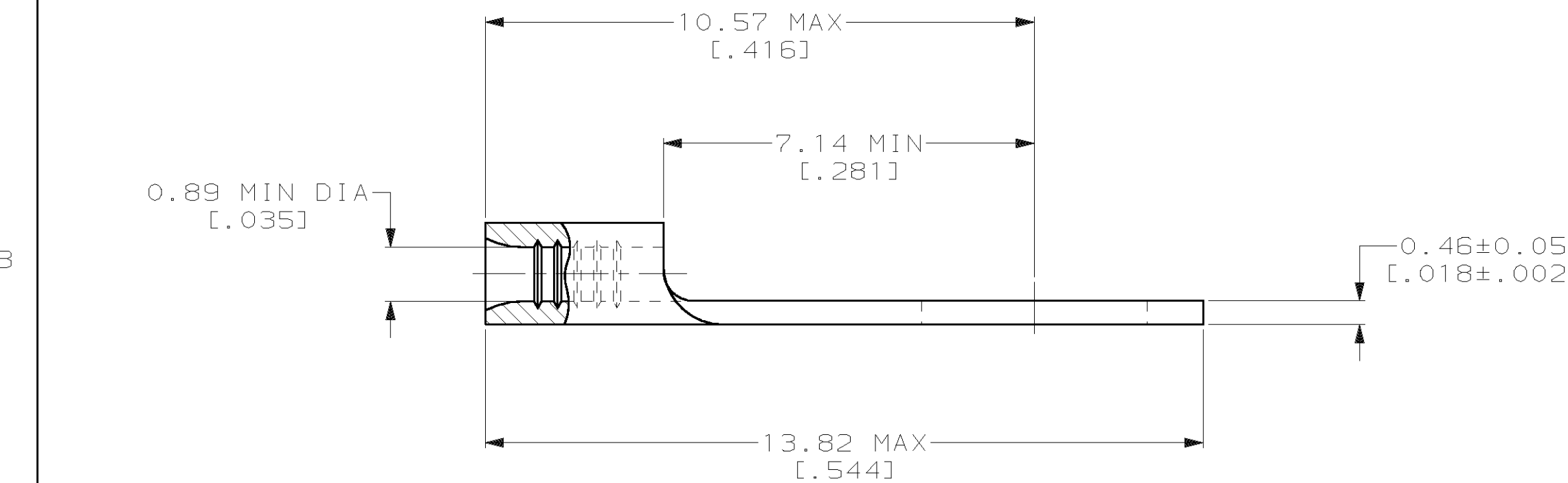

③	32860-1
②	32860
FINISH	PART NO

AMP INCORPORATED
CUSTOMER SERVICE SYSTEMS

FOR ADDITIONAL PRODUCT INFORMATION OR COPIES OF DRAWINGS AND TECHNICAL DOCUMENTS	PRODUCT INFORMATION CENTER 1-800-522-6752
FOR APPLICATION TOOLING INFORMATION	TOOLING ASSISTANCE CENTER 1-800-722-1111
FOR ORDER ENTRY	1-800-526-5142

MAX RECOMMENDED OPERATING TEMPERATURE:
 170°C MAX

VOLTAGE RATING:
 NOT APPLICABLE

WIRE CROSS SECTIONAL AREA RANGE:
 0.1-0.41mm² [202-810] CIR MILS
 STRANDED

THIS DRAWING IS A CONTROLLED DOCUMENT FOR AMP INCORPORATED. IT IS SUBJECT TO CHANGE AND THE CONTROLLING ENGINEERING ORGANIZATION SHOULD BE CONTACTED FOR THE LATEST REVISION.

DO NOT SCALE PRINT. UNLESS SPECIFIED DIMENSIONS IN mm [INCHES] TOLERANCES ON:

DR 2-2-93 TA BRINKMAN	CHK 2-2-93 DA PATTERSON
APPD 2-2-93 DE MILLER	APPD 2-2-93 JL MECKLEY
MATERIAL COPPER PER ASTM B-152 ANNEALED	PRODUCT SPEC -
FINISH -	APPLICATION SPEC -
WEIGHT -	

AMP AMP Incorporated
 Harrisburg, PA 17105-3608

NAME
**TERMINAL, RING
 TONGUE, BUDGET**

SIZE C	CAGE CODE 00779	DRAWING NO C-32860
SCALE 10:1	SHEET 1 OF 1	