

LOC	DIST	REV	DESCRIPTION	DATE	DWN	APVD
FT	0	D5	EDITED NOTES PER ECO-11-013836	15JUL2011	DW	JE

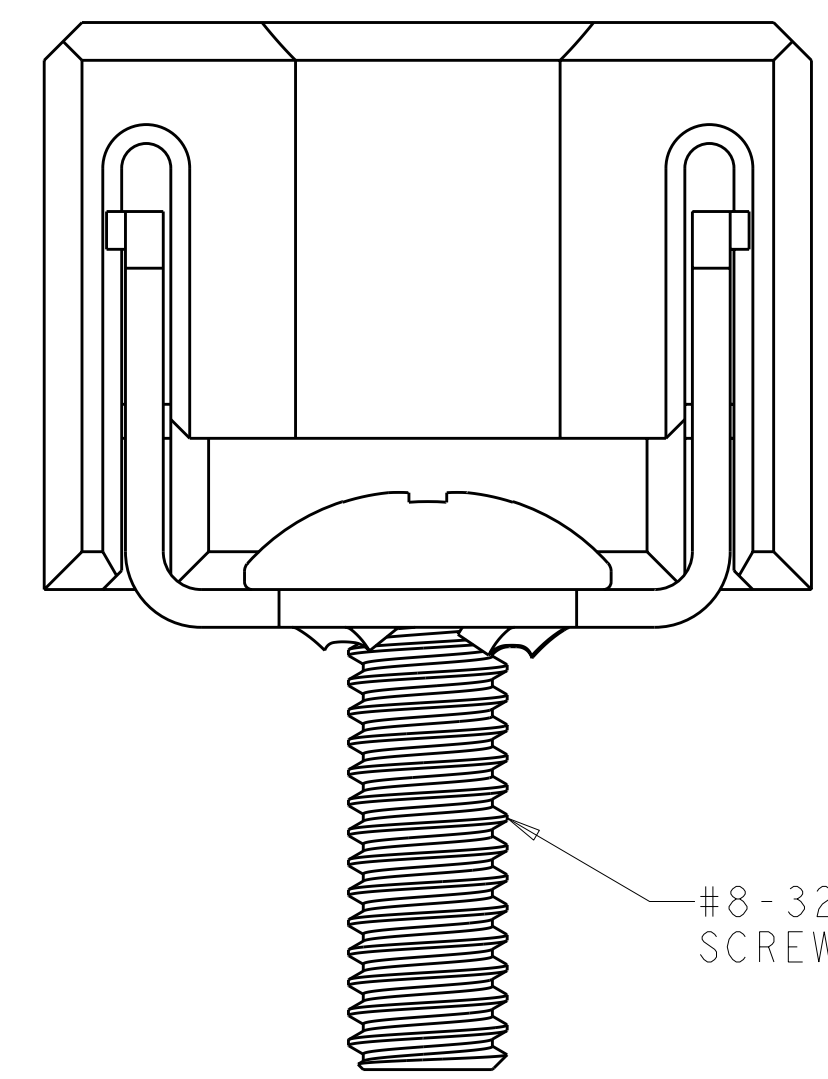

#8-32 PAN HEAD SCREW

1954381-2 & -3

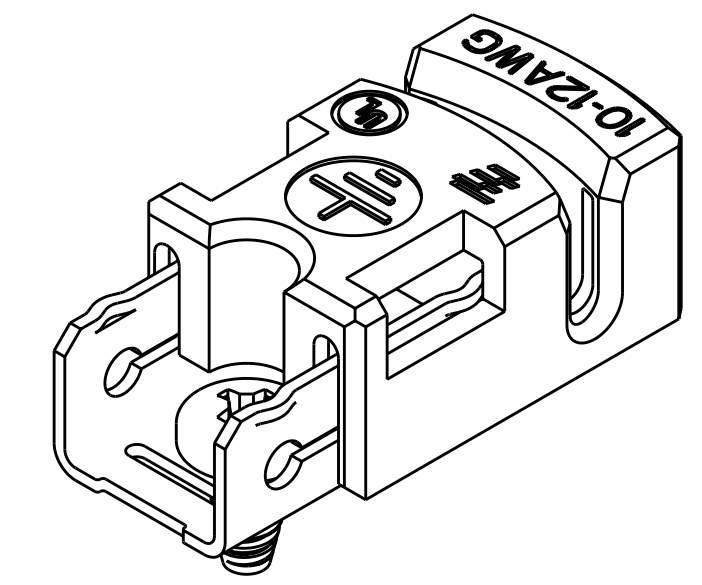
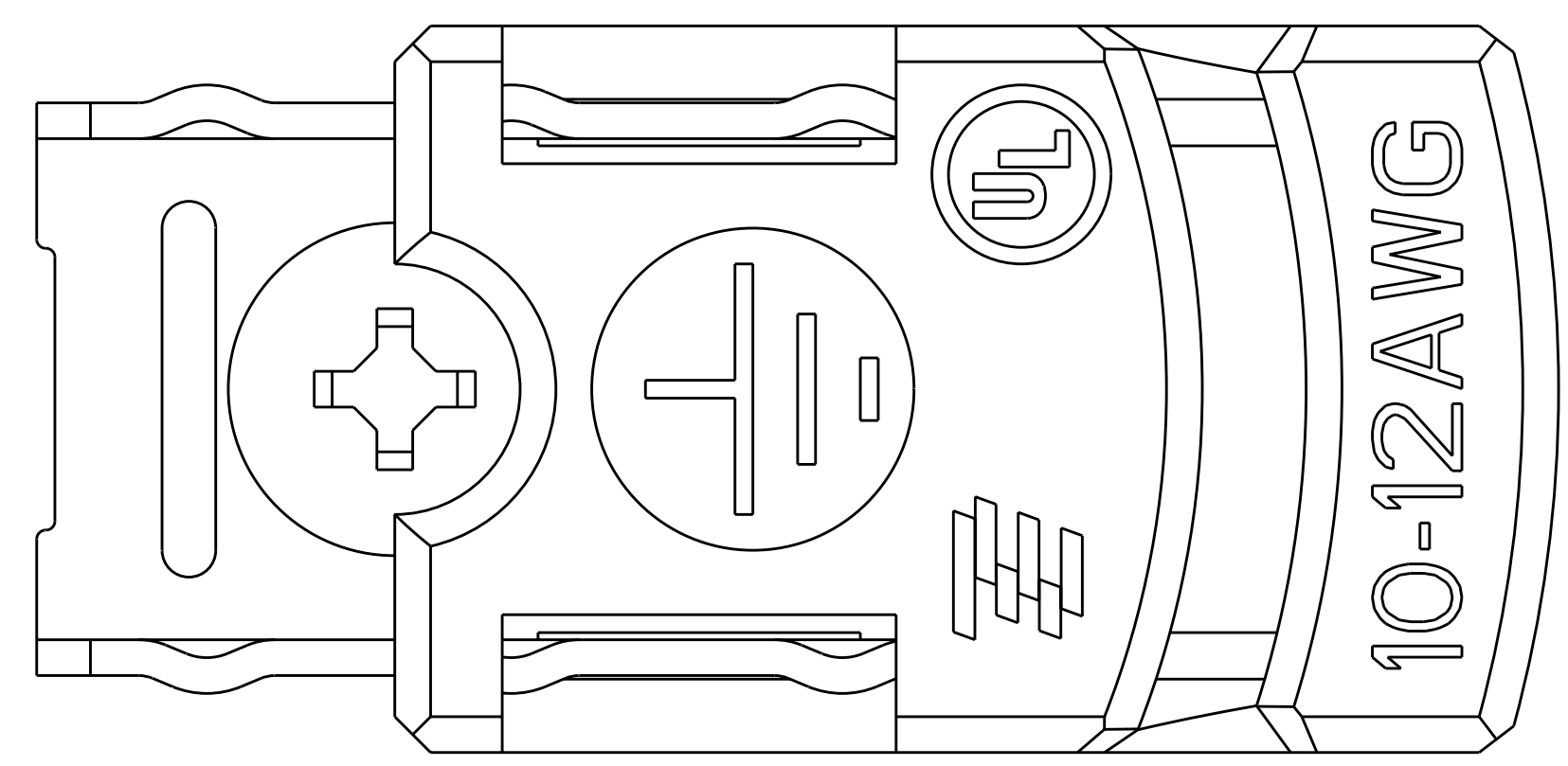
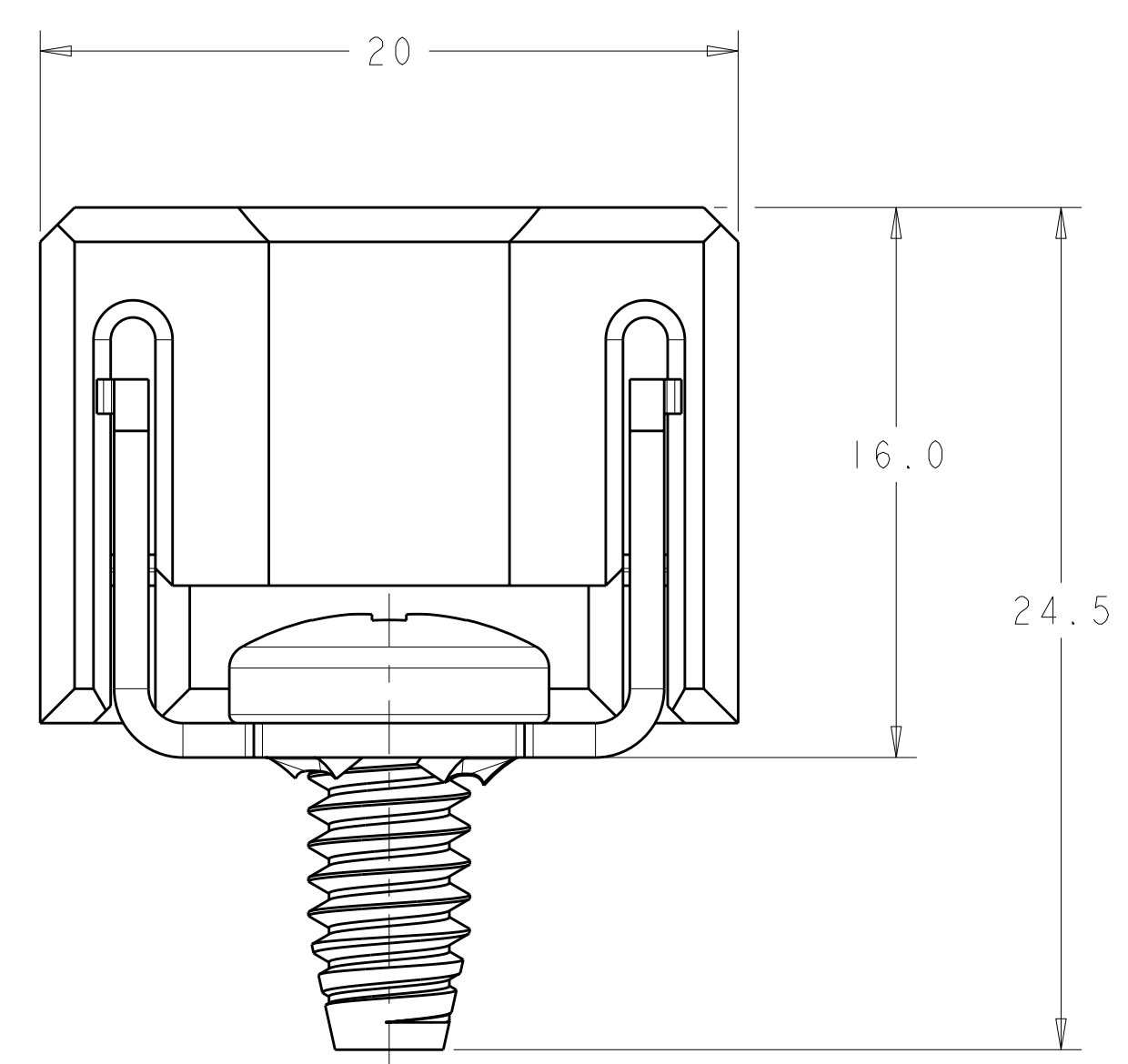

SCALE 2:1

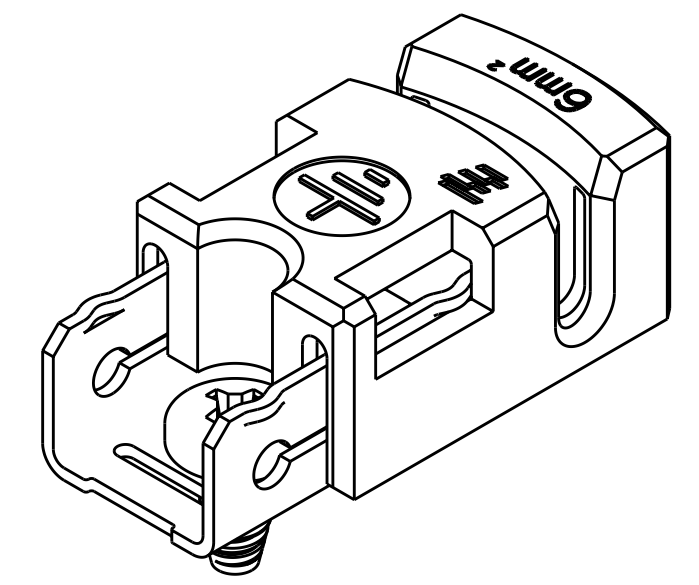

SCALE 2:1
1954381-5 ONLY

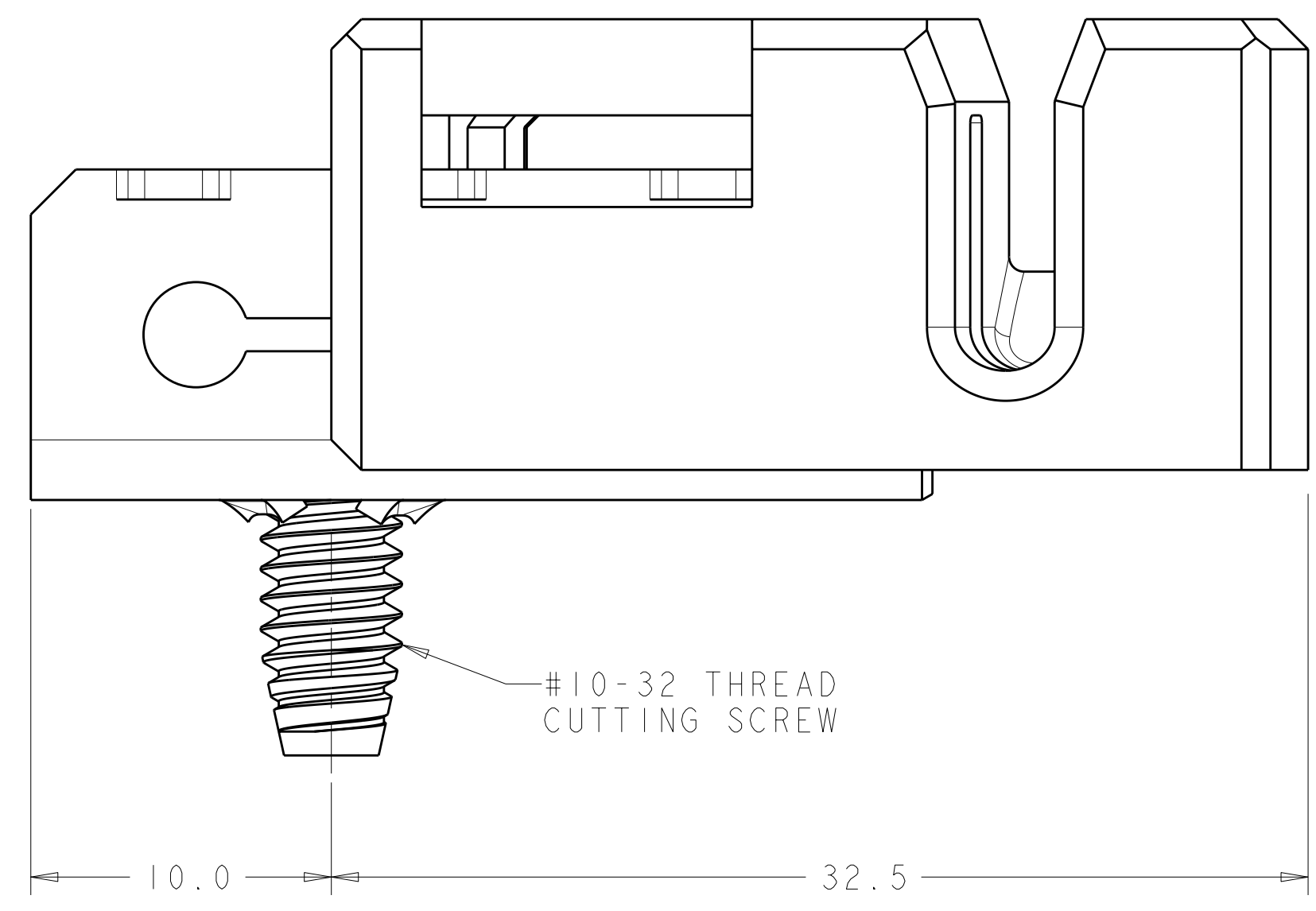

#10-32 THREAD CUTTING SCREW

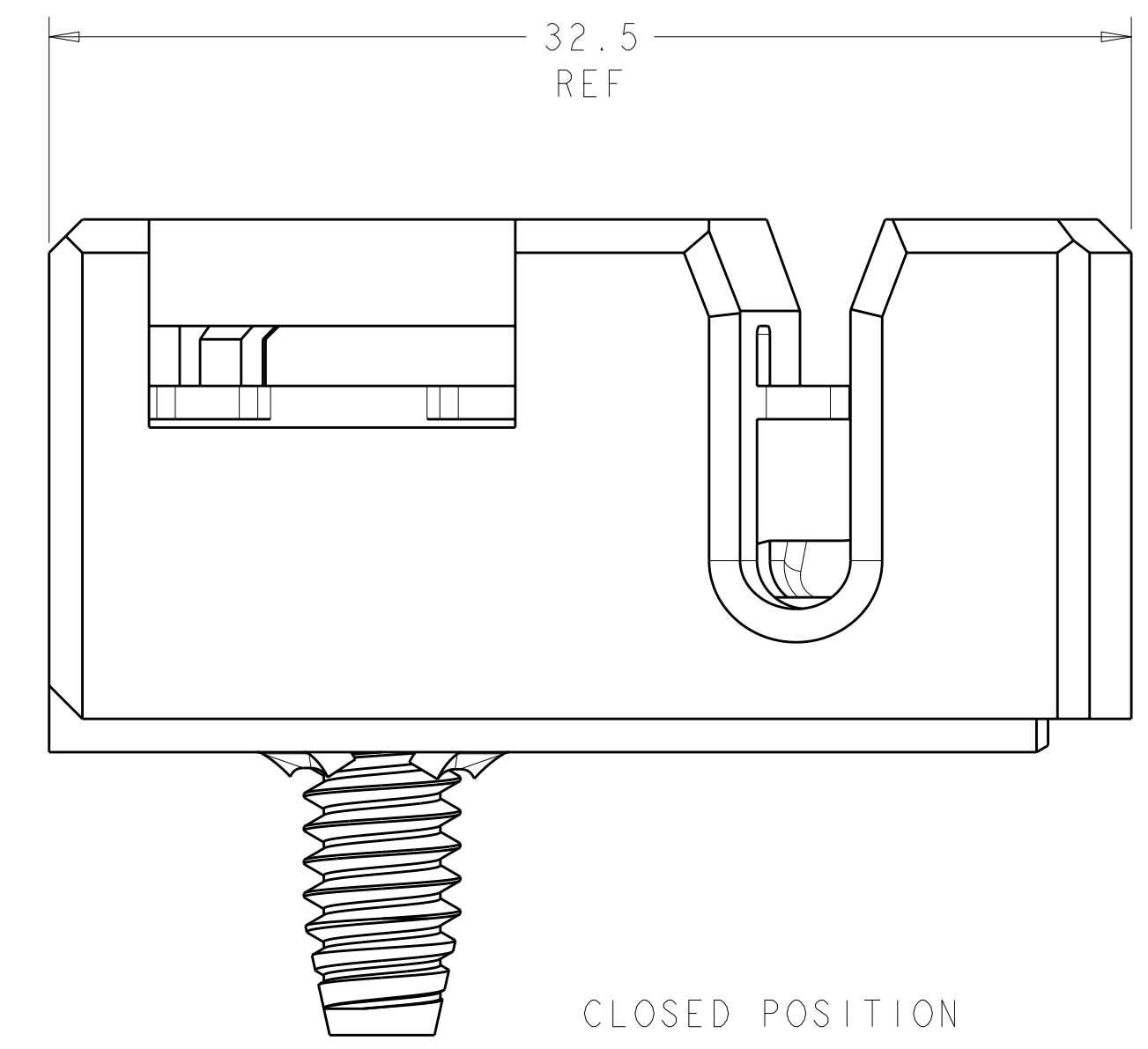

CLOSED POSITION

△ MATERIALS AND FINISH:
 SLIDER: PBT, UV F1 RATING, BLACK, 94V5
 BASE: PHOSPHOR BRONZE; FINISH: Sn OVER Ni
 MOUNTING HARDWARE: STAINLESS STEEL EXCEPT #8-32 HEX NUT WHICH IS CARBON STEEL

2. COMPLIES WITH DIRECTIVE 2002/95/EC (ROHS)
3. PATENTED.

△ NUTS ARE PACKAGED SEPERATELY IN A BAG.

NONE	NONE	6mm ² AND 4mm ²	1954381-6
NONE	#10-32 THREAD CUTTING .375LG	6mm ² AND 4mm ²	1954381-5
△ NUT WITH LOCKWASHER	#10-32 PAN HEAD .625LG	10-12 AWG, 4mm ²	1954381-4
△ NUT WITH LOCKWASHER	#8 PAN HEAD .500LG	10-12 AWG, 4mm ²	1954381-3
△ HEX NUT	#8-32 PAN HEAD .500LG	10-12 AWG, 4mm ²	1954381-2
NONE	#10-32 THREAD CUTTING .375LG	10-12 AWG, 4mm ²	1954381-1
NUT	SCREW	WIRE SIZE	PART NUMBER

THIS DRAWING IS A CONTROLLED DOCUMENT.		DWN: MOHAN 31OCT2006	TE Connectivity
DIMENSIONS: mm		CHK: S. DUESTERHOFF 01NOV2006	
TOLERANCES UNLESS OTHERWISE SPECIFIED:		APVD: M. STROCKWALD 01JUN2007	NAME: GROUNDING CLIP ASSEMBLY SOLID WIRE
0 PLC ±.1 1 PLC ±.10 2 PLC ±.15 3 PLC ±.2 4 PLC ±.25 ANGLES ±°	FINISH	PRODUCT SPEC	APPLICATION SPEC
MATERIAL	FINISH	WEIGHT	SIZE CAGE CODE DRAWING NO
CUSTOMER DRAWING		SCALE 5:1	SHEET 1 OF 1 REV D5