

4

3

2

1

THIS DRAWING IS UNPUBLISHED.

RELEASED FOR PUBLICATION

© COPYRIGHT -- By TE CONNECTIVITY

ALL RIGHTS RESERVED.

LOC
HBDIST
--

REVISIONS

P	LTR	DESCRIPTION	DATE	DWN	APVD
1		CHANGE THE WIDTH OF THE PIN TERMINAL FROM 0.8MM TO 0.9MM	ECO-14-011875	19-AUG-14	Q.L.B.F

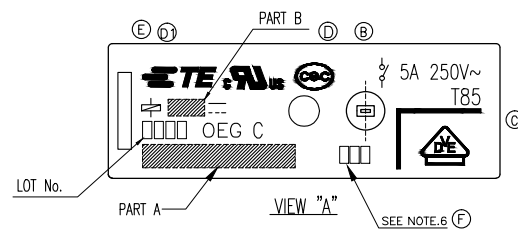
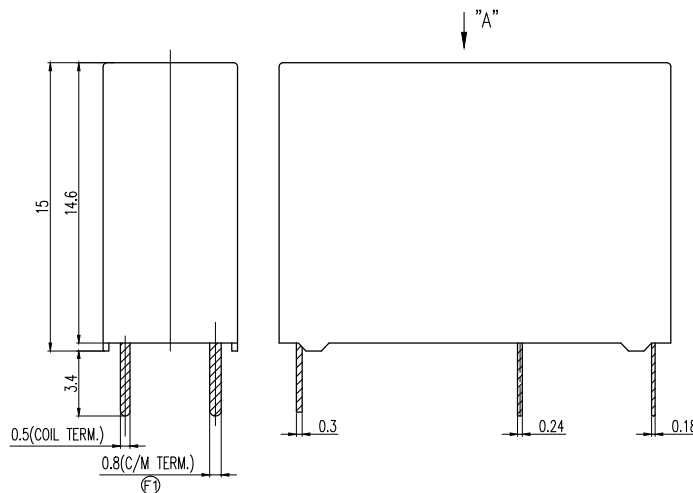

DRILLING DIAGRAM (BOTTOM VIEW)

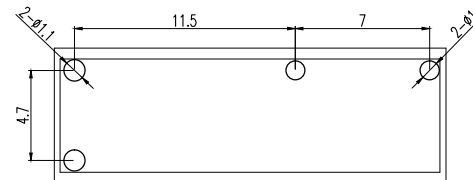

CIRCUIT DIAGRAM (BOTTOM VIEW)

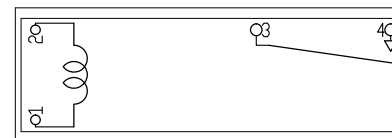

© NOTE:

1. LOT NO. SYSTEM AS FOLLOWING;

WEEK
YEAR

② 2. ONE CHARACTER DISTINGUISH THE LINE IDENTITY, SUCH AS: A, B...

③ 3. TERMINAL DIMENSION IS BEFORE SOLDER DIP.

④ 4. FOR THE TIN-PLATING OF THE PINS:

+0.1mm FOR WIDTH, THICKNESS AND DIAMETER.

+0.5mm FOR LENGTH.

⑤ 5. MARKING FROM INK CHANGE TO LASER

⑥ 6. ADD LOT NO. SYSTEM AS FOLLOWING;



I. DIGITS FOR DAY OF THE WEEK

1...MONDAY IN THIS WEEK;

2...TUESDAY IN THIS WEEK;

.....

7...SUNDAY IN THIS WEEK

II. DIGITS FOR SHIFT OF THE DAY

1...DAY SHIFT IN THIS DAY;

2...NIGHT SHIFT IN THIS DAY;

III. ONE CHARACTER DISTINGUISH THE LINE IDENTITY, SUCH AS: A, B,Z

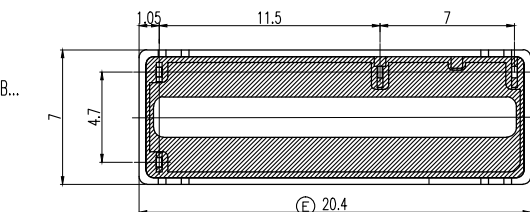

Diagram dimension	Tolerance
0.99mm max.	±0.1mm
1 - 2.99mm	±0.2mm
3mm min.	±0.3mm

THIS DRAWING IS A CONTROLLED DOCUMENT.

DIMENSIONS:

mm



TOLERANCES UNLESS OTHERWISE SPECIFIED:

0 PLC	±	-
1 PLC	±	-
2 PLC	±	-
3 PLC	±	-
4 PLC	±	-
ANGLES	±	-

MATERIAL

FINISH

DWN

CHK

APVD

PRODUCT SPEC

APPLICATION SPEC

WEIGHT

CUSTOMER DRAWING

DWN

CHK

APVD

PRODUCT SPEC

APPLICATION SPEC

WEIGHT

CUSTOMER DRAWING

NAME

NAME

PCJ-WG,000M SPEC

SIZE

CAGE CODE

DRAWING NO

RESTRICTED TO

A3

00779

C=1721547

-

SCALE

5:1

SHEET

1 of 2

REV

F1

4

3

2

1

THIS DRAWING IS UNPUBLISHED. RELEASED FOR PUBLICATION
 © COPYRIGHT - By TE CONNECTIVITY ALL RIGHTS RESERVED.

LOC	DIST	REVISIONS			
P	LTR	DESCRIPTION	DATE	DWN	APVD
HB	-	SEE SHEET 1	-	-	-

N	PCJ-12403MH-WG, 000M	1-1721547-4	SEAL UP INSPECTION ON EVERY PRODUCT	24V	PCJ-12403MH-WG
M	PCJ-11803MH-WG, 000M	1-1721547-3	SEAL UP INSPECTION ON EVERY PRODUCT	18V	PCJ-11803MH-WG
L	PCJ-11203MH-WG, 000M	1-1721547-2	SEAL UP INSPECTION ON EVERY PRODUCT	12V	PCJ-11203MH-WG
K	PCJ-10803MH-WG, 000M	1-1721547-1	SEAL UP INSPECTION ON EVERY PRODUCT	9V	PCJ-10803MH-WG
J	PCJ-10603MH-WG, 000M	1-1721547-0	SEAL UP INSPECTION ON EVERY PRODUCT	6V	PCJ-10603MH-WG
I	PCJ-10503MH-WG, 000M	1721547-9	SEAL UP INSPECTION ON EVERY PRODUCT	5V	PCJ-10503MH-WG
H	PCJ-10303MH-WG, 000M	1721547-8	SEAL UP INSPECTION ON EVERY PRODUCT	3V	PCJ-10303MH-WG
G	PCJ-12403M-WG, 000M	1721547-7	SEAL UP INSPECTION ON EVERY PRODUCT	24V	PCJ-12403M-WG
F	PCJ-11803M-WG, 000M	1721547-6	SEAL UP INSPECTION ON EVERY PRODUCT	18V	PCJ-11803M-WG
E	PCJ-11203M-WG, 000M	1721547-5	SEAL UP INSPECTION ON EVERY PRODUCT	12V	PCJ-11203M-WG
D	PCJ-10803M-WG, 000M	1721547-4	SEAL UP INSPECTION ON EVERY PRODUCT	9V	PCJ-10803M-WG
C	PCJ-10603M-WG, 000M	1721547-3	SEAL UP INSPECTION ON EVERY PRODUCT	6V	PCJ-10603M-WG
B	PCJ-10503M-WG, 000M	1721547-2	SEAL UP INSPECTION ON EVERY PRODUCT	5V	PCJ-10503M-WG
A	PCJ-10303M-WG, 000M	1721547-1	SEAL UP INSPECTION ON EVERY PRODUCT	3V	PCJ-10303M-WG
No.	DESCRIPTION	TE PART NO	DESCRIPTION	PART B	PART A

RELAY TYPE

	Sn-Ag-Cu	SOLDER	18	
94V-0	PA	⊕ CASE	17	
	UV	SEAL(CASE) JUST FOR WASH TIGHT	16	
	EPOXY	SEAL(CASE AND BASE)	15	
	SUEW	MAGNETIC WIRE	14	
94V-0	PBT	CARD	13	
	Ag ALLOY	STATIONARY CONTACT	12	
	Cu ALLOY	STATIONARY TERMINAL	11	
	Ag ALLOY	MOVABLE CONTACT	10	
	SOLDER DIP	Cu ALLOY MOVABLE SPRING	9	
94V-0	PET	⊕ BASE	8	
	STAINLESS	HINGE SPRING	7	
	NIP	STEEL ARMATURE	6	
	NIP	STEEL CORE	5	
	NIP	STEEL YOKE	4	
	SOLDER DIP	Cu ALLOY COIL TERMINAL B	3	
	SOLDER DIP	Cu ALLOY COIL TERMINAL A	2	
94V-0	PBT	BOBBIN	1	
COMBUSTIBILITY	TREATMENT	MATERIAL	DESCRIPTION	TEM

THIS DRAWING IS A CONTROLLED DOCUMENT.		DWN	TE Connectivity	
DIMENSIONS: mm		CHK	NAME	
		APVD	PCJ-WG,000M SPEC	
TOLERANCES UNLESS OTHERWISE SPECIFIED:		PRODUCT SPEC	SIZE	
0 PLC ± -		APPLICATION SPEC	CAGE CODE	DRAWING NO
1 PLC ± -		WEIGHT	A3	00779
2 PLC ± -		CUSTOMER DRAWING	SCALE	5:1
3 PLC ± -		RESTRICTED TO	SHEET	2 OF 2
4 PLC ± -		REV	REV	F1
ANGLES ± -		DRAWING NO: 1721547		
FINISH		SCALE: 5:1 SHEET: 2 OF 2 REV: F1		