

THIS DRAWING IS UNPUBLISHED. RELEASED FOR PUBLICATION
 BY AMP INCORPORATED. ALL RIGHTS RESERVED.

LOC	DIST	REVISIONS			
P	LTR	DESCRIPTION	DATE	DWN	APVD
BD	36	U	REDRAWN PER EC 0020-1346-95	16 JAN 96	-

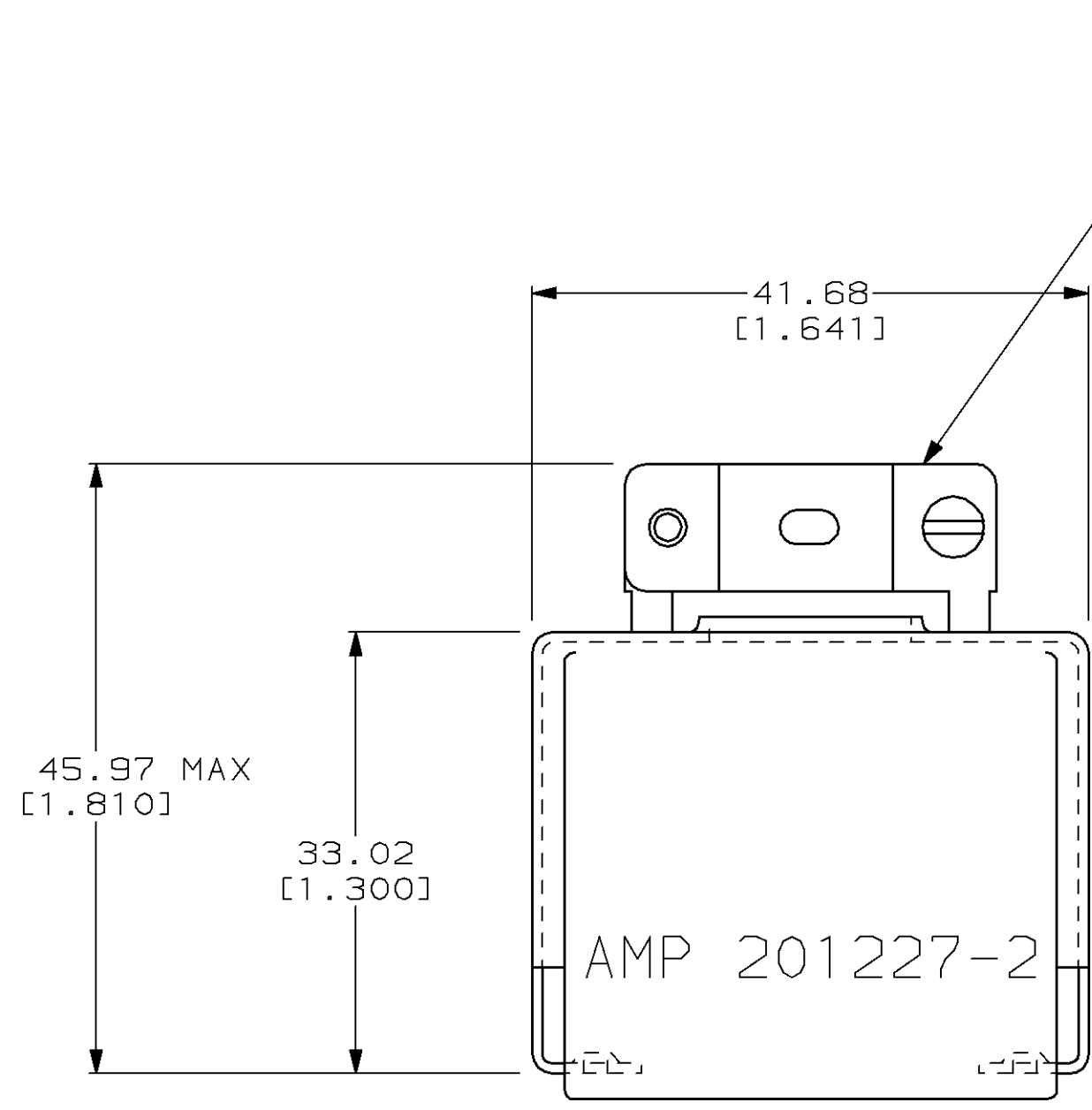

CABLE CLAMP
 MATERIAL: CARBON STEEL
 FINISH: 5.08µm [.000200] MIN NICKEL
 2 EACH

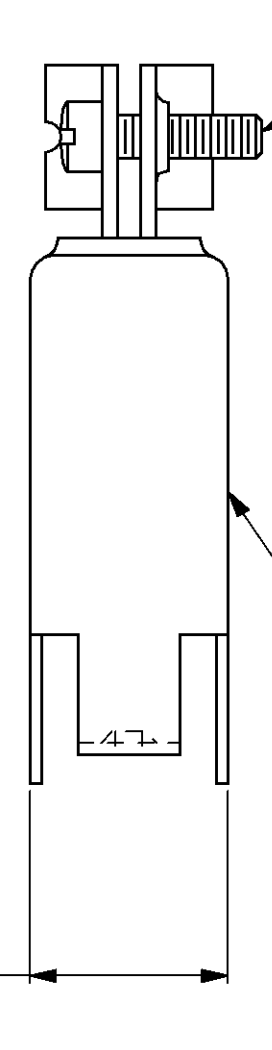

4-40 UNC FILLISTER HEAD SCREW
 MATERIAL: CARBON STEEL
 FINISH: 3.81µm [.000150] MIN ZINC
 2 EACH

SHIELD
 MATERIAL: CARBON STEEL
 FINISH: 5.08µm [.000200] MIN NICKEL

ASSEMBLED VIEW

1. CABLE CLAMP WILL ACCEPT 20 WIRES OF 1.78 [.070] MAX DIA.

201227-2
 PART NUMBER

<small>THIS DRAWING IS A CONTROLLED DOCUMENT FOR AMP INCORPORATED. IT IS SUBJECT TO CHANGE AND THE CONTROLLING ENGINEERING ORGANIZATION SHOULD BE CONTACTED FOR THE LATEST REVISION.</small>		DWN C. DORWART 16 JAN 96 CHK R. STONE 29 FEB 96 APVD G. STEINHAUER 07 MAR 96	AMP AMP Incorporated Harrisburg, PA 17105-3608
DIMENSIONS: mm [INCHES]	TOLERANCES UNLESS OTHERWISE SPECIFIED: 0 PLC ±- 1 PLC ±- 2 PLC ±0.41 [.016] 3 PLC ±- 4 PLC ±- ANGLES ±- FINISH -	PRODUCT SPEC - APPLICATION SPEC - WEIGHT -	NAME SIZE A2 CAGE CODE 00779 DRAWING NO. C-201227 SCALE 2:1 SHEET 1 OF 1 REV U
MATERIAL - CUSTOMER DRAWING			SHIELD KIT, UNASSEMBLED, 20 POSITION, M SERIES

201227