

MODEL CUB7P3 - PROGRAMMABLE ELECTRONIC 8-DIGIT COUNTER



- 3 (8 Digit 0.35") LCD DISPLAY OPTIONS (Reflective, Red Transmissive, Yellow/Green Transmissive. 9 to 28 VDC power supply required for versions w/ LED backlighting)
- AVAILABLE VOLTAGE INPUTS (10 TO 30 VAC/DC)
- PRESCALER FROM 0.0001 TO 1.9999
- SELECTABLE DECIMAL POINTS
- REPLACEABLE INTERNAL LITHIUM BATTERY PROVIDES UP TO 6 YEARS OF UNINTERRUPTED OPERATION (Battery Included)
- WIRE CONNECTIONS VIA SCREW CLAMP TYPE TERMINALS
- FRONT PANEL AND REMOTE RESET INPUT
- NEMA 4X/IP65 SEALED FRONT BEZEL
- BOTH FRONT PANEL PROGRAM AND RESET BUTTONS ARE INDIVIDUALLY ENABLED

DESCRIPTION

The CUB7P3 is an 8-digit miniature programmable counter with large 0.35 inch (8.90 mm) high digits. It has an LCD read-out available in Positive Image Reflective, Negative Image Transmissive with yellow/green backlighting, or red backlighting. Backlight units require an external 9 to 28 VDC power supply. The CUB7P3 versions operate from a signal voltage of 10 to 30 V (AC 50/60 Hz or DC).

The CUB7P3 has a programmable prescaler that can be set for any value between 0.0001 and 1.9999. The decimal point position can be set anywhere from 0 (no D.P.) to 0.000000 or no Leading Zero Blanking. Both the prescaler and DP selection are accessed using the front panel PGM and RESET push buttons. See Programming for details. Note that the count, prescaler and DP values will be lost if the battery is removed. See BATTERY INSTALLATION for additional information.

The CUB7P counters use a CMOS LSI chip, mounted on a gold-plated substrate, that is electrically connected by ultrasonic wire-bonding. Proven micro-electronic assembly and manufacturing techniques provide these units with the reliability and dependability required for industrial service.

The CUB7P series is housed in a lightweight, high impact plastic case with a clear viewing window. The sealed front panel with the silicone rubber buttons meets NEMA 4X/IP65 specifications for wash-down and/or dusty environments, when properly installed.

SAFETY SUMMARY

All instructions that appear in the bulletin or on equipment, all safety related regulations, and all local codes must be observed to ensure personal safety and to prevent damage to either the instrument or equipment connected to it. If equipment is used in a manner not specified by the manufacturer, the protection provided by the equipment may be impaired.



ORDERING INFORMATION

MODEL NO.	DESCRIPTION	PART NUMBER
*CUB7P3	Counter; Positive Image Reflective	CUB7P300
	Counter, w/Yel-Grn Backlighting	CUB7P310
	Counter; w/Red Backlighting	CUB7P320
BNL	Replacement 3 V Lithium Battery	BNL10000

* Battery is included with unit.

DIMENSIONS In inches (mm)

Note: Recommended minimum clearance (behind the panel) for mounting clip installation is 2.1" (53.4) H x 5.5" (140) W.

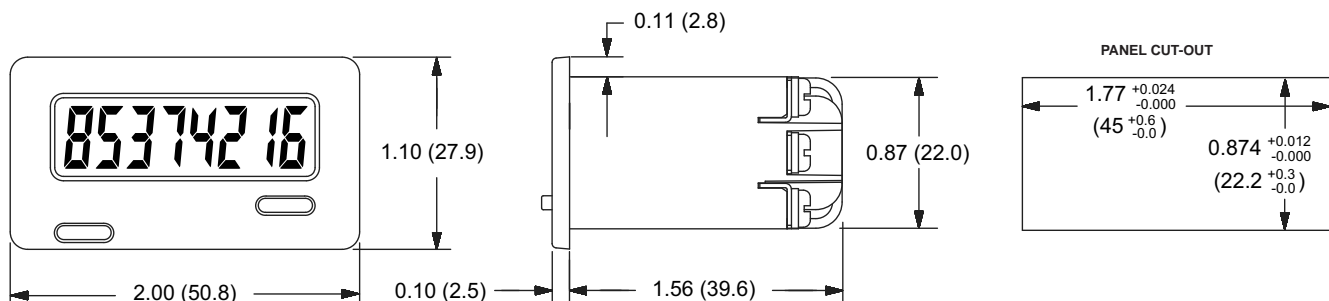

SPECIFICATIONS

- DISPLAY:** 8-digit LCD, 0.35" (8.90 mm) high digits.
- POWER SOURCE:** Replaceable Internal 3.0 V lithium battery to provide up to 6 years of continuous operation. (Battery life is dependent upon usage. Contacts that remain closed for long periods of time reduce battery life.)
- BACKLIGHT POWER REQUIREMENTS:** 9 to 28 VDC; 35 mA. typical, 50 mA max. Above 26 VDC, derate max. operating temperature to 40°C. Must use a NEC Class 2 or SELV rated power supply.
- SIGNAL INPUT:** (LS terminal #4) See *Count Edge* under Programming for incrementing edge of input signal.

Voltage Input (CUB7P3xx): 10 V min. to 30 V max. (AC 50/60 Hz. or DC) to Common. 30 cps max. ANY off-state leakage current may prevent counter from activating.

- REMOTE RESET:** 15 msec min. pulse width (active low) from 3.0 V bipolar output, an open collector transistor, or a switch contact to common.
- ENVIRONMENTAL CONDITIONS:**

Operating Temperature Range: 0 to 50°C Derate max. operating temperature to 40°C above 26 VDC (Backlight versions).

Storage Temperature: -30 to 80°C

Operating and Storage Humidity: 85% max. relative humidity (non-condensing) from 0°C to 50°C.

Vibration According to IEC 68-2-6: Operational 5 to 500 Hz, in X, Y, Z direction for 1.5 hours, 5 g's.

Shock According to IEC 68-2-27: Operational 30 g's, 11 msec in 3 directions.

Altitude: Up to 2000 meters

- CERTIFICATIONS AND COMPLIANCES:**

SAFETY

Type 4X Indoor Enclosure rating (Face only)

IEC-61010-1, EN 61010-1: Safety requirements for electrical equipment for measurement, control, and laboratory use, Part 1.

IP65 Enclosure rating (Face only), IEC 529

ELECTROMAGNETIC COMPATIBILITY

Immunity to EN 50082-2

Electrostatic discharge	EN 61000-4-2	Level 2; 4 Kv contact Level 3; 8 Kv air
Electromagnetic RF fields	EN 61000-4-3	Level 3; 10 V/m 80 MHz - 1 GHz
Fast transients (burst)	EN 61000-4-4	Level 4; 2 Kv I/O Level 3; 2 Kv power ¹
RF conducted interference	EN 61000-4-6	Level 3; 10 V/rms 150 KHz - 80 MHz
Simulation of cordless telephone	ENV 50204	Level 3; 10 V/m 900 MHz ± 5 MHz 200 Hz, 50% duty cycle

Emissions to EN 50081-1

RF interference	EN 55022	Enclosure class B
-----------------	----------	-------------------

Notes

1. Backlit powered units require a power line filter to be installed, RLC LFIL0000 or equivalent, so as not to impair the function of the backlighting.

Refer to EMC Installation Guidelines for additional information.

- CONSTRUCTION:** High impact plastic case with clear viewing window. The front panel meets NEMA 4X/IP65 requirements for indoor use when properly installed. Installation Category I, Pollution Degree 2. Panel gasket and mounting clip included.
- CONNECTIONS:** Wire clamping screw terminals
Wire Strip Length: 0.3" (7.5 mm).
Wire Gauge: 30-14 AWG copper wire
Torque: 5 inch-pounds (0.565 N-m) max.
- WEIGHT:** 2 oz. (57 grams) [with battery]

PROGRAMMING

The CUB7P has programmable prescale values and decimal point positions. These values are changed using the front panel push buttons. Connect wires between RST EN (Reset Enable) and COM. (Common); and between HS (Program Enable) and COM. (Common) to enable front panel push buttons.

Note: Upon entering the PGM mode for the first time, the Prescaler value is set to 0.0000. Some value between 0.0001 and 1.9999 must be entered in order for the CUB7P to operate properly. Previously stored values are retained until changed by the user.

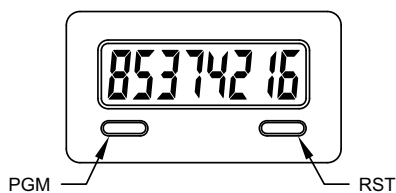

With the front panel push buttons enabled, press the PGM button to enter the program mode. The CUB7P display will change to the current prescale value, with the least significant digit flashing at a 2 Hz rate. The prescale value can be set to any value between 0.0001 and 1.9999. Press the RST button to increment the flashing digit to the desired value. Pressing the PGM button will lock in the value of the flashing digit and advance to the next significant digit. The most significant digit can only be set to 0 or 1. When the entire prescale value has been programmed, press the PGM button once to enable decimal point selection. Any new count pulses will be accumulated using the new prescale value.

After performing the prescale selection, the display will show 0.0000. Decimal point positions can be set for:

```

0
0.0
0.00
0.000
0.0000 (Default)
0.00000
0.000000
00000000
    
```

Press the RST button until the desired decimal point position is displayed. Press the PGM button to select that position and return to the counter mode. Remove the wire from the HS (Program Enable) terminal to prevent accidental changes to the programmed values.

Note: The incrementing edge of the count signal will change when the PGM button is pressed for the first time. To avoid incorrect display information, it is recommended that the CUB7P be reset after making programming changes.

COUNT EDGE

Accessing program mode for the first time will complement the incrementing edge of the count signal. See below for the incrementing edge of the count signal for the CUB7P3:

After installing or replacing battery: Falling Edge

After entering program mode: Rising Edge

EMC INSTALLATION GUIDELINES

Although this unit is designed with a high degree of immunity to ElectroMagnetic Interference (EMI), proper installation and wiring methods must be followed to ensure compatibility in each application. The type of the electrical noise, source or coupling method into the unit may be different for various installations. In extremely high EMI environments, additional measures may be needed. The unit becomes more immune to EMI with fewer I/O connections. Cable length, routing and shield termination are very important and can mean the difference between a successful or a troublesome installation. Listed below are some EMC guidelines for successful installation in an industrial environment.

- Use shielded (screened) cables for all Signal and Control inputs. The shield (screen) pigtail connection should be made as short as possible. The connection point for the shield depends somewhat upon the application. Listed below are the recommended methods of connecting the shield, in order of their effectiveness.
 - Connect the shield only at the panel where the unit is mounted to earth ground (protective earth).
 - Connect the shield to earth ground at both ends of the cable, usually when the noise source frequency is above 1 MHz.
 - Connect the shield to common of the unit and leave the other end of the shield unconnected and insulated from earth ground.
- Never run Signal or Control cables in the same conduit or raceway with AC power lines, conductors feeding motors, solenoids, SCR controls, and heaters, etc. The cables should be run in metal conduit that is properly grounded. This is especially useful in applications where cable runs are long and portable two-way radios are used in close proximity or if the installation is near a commercial radio transmitter.
- Signal or Control cables within an enclosure should be routed as far away as possible from contactors, control relays, transformers, and other noisy components.
- In extremely high EMI environments, the use of external EMI suppression devices, such as ferrite suppression cores, is effective. Install them on Signal and Control cables as close to the unit as possible. Loop the cable through the core several times or use multiple cores on each cable for additional protection. Install line filters on the power input cable to the unit to suppress power line interference. Install them near the power entry point of the enclosure. The following EMI suppression devices (or equivalent) are recommended:

Ferrite Suppression Cores for signal and control cables:

Fair-Rite # 0443167251 (RLC #FCOR0000)
 TDK # ZCAT3035-1330A
 Steward #28B2029-0A0
 Line Filters for input power cables:
 Schaffner # FN610-1/07 (RLC #LFIL0000)
 Schaffner # FN670-1.8/07
 Corcom #1VR3

Note: Reference manufacturer's instructions when installing a line filter.

5. Long cable runs are more susceptible to EMI pickup than short cable runs. Therefore, keep cable runs as short as possible.

WARNING: Lithium battery may explode if incinerated. To prevent damage to the unit, the voltage on all inputs must not exceed 3.0 VDC with the following exceptions: V+ (all models: 28 VDC max.) and LS (voltage versions: 30 V max.).



WIRING CONNECTIONS

The electrical connections are made via screw-clamp terminals located on the back of the unit. All conductors should meet voltage and current ratings for each terminal. Also, cabling should conform to appropriate standards of good installation, local codes and regulations. It is recommended that power supplied to the unit be protected by a fuse or circuit breaker. When wiring the unit, use the battery cover to identify the wire position with the proper function. Strip the wire, leaving approximately 1/4" bare wire exposed (stranded wires should be tinned with solder). Insert the wire under the screw-clamp and tighten down the screw until the wire is clamped in tightly. Each terminal can accept up to two #14 AWG wires.

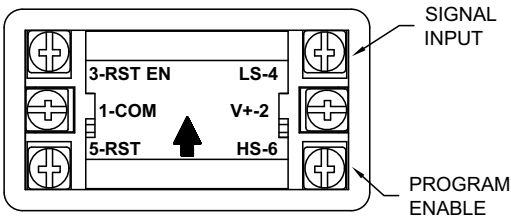

WARNING: Lithium battery may explode if incinerated.



BATTERY INSTALLATION

1. Remove all power to the unit before removing battery cover.
2. To remove the battery cover, push upward in the direction of the arrow on the rear cover (See drawing below), until the cover unlatches. Pull the cover straight out from unit to fully remove.
3. Remove old battery* and replace it with an RLC battery (BNL10000). Observe proper polarity when replacing the battery as shown in the drawing.
4. Replace the cover. The battery cover is keyed so that it cannot be placed upside down. The arrow on the rear of the cover should point toward the top of the CUB7P when properly installed.

* - Dispose of properly.

WARNING: Lithium battery may explode if incinerated.

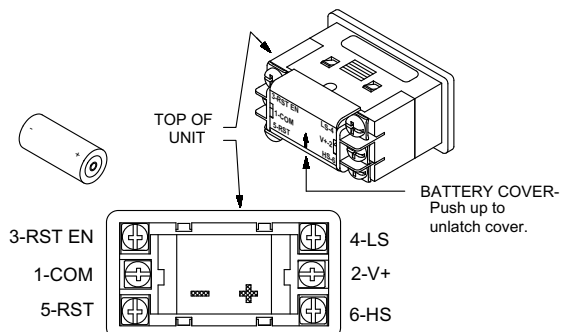
INSTALLATION ENVIRONMENT

The unit should be installed in a location that does not exceed the maximum operating temperature and provides good air circulation. Placing the unit near devices that generate excessive heat should be avoided.

The bezel should be cleaned only with a soft cloth and neutral soap product. Do NOT use solvents. Continuous exposure to direct sunlight may accelerate the aging process of the bezel. Do not use tools of any kind (screwdrivers, pens, pencils, etc.) to operate the push buttons of the unit.

INSTALLATION

The CUB7P meets NEMA 4X/IP65 requirements for indoor use when properly installed. The units are intended to be mounted into an enclosed panel. The viewing window and reset button are factory sealed for a washdown environment. A sponge rubber gasket and mounting clip are provided for installing the unit in the panel cut-out.

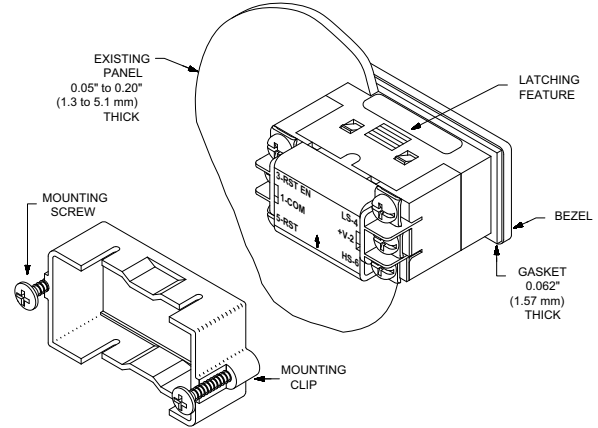

The following procedure assures proper installation:

1. Cut panel opening to specified dimensions. Remove burrs and clean around panel opening.
2. Carefully remove and discard the center section of the gasket.
3. Slide the panel gasket over the rear of the counter body to the back of the bezel. Install CUB7P unit through the panel cut-out.
4. Insert the mounting screws onto both sides of mounting clip. Tip of screw should NOT project from hole in mounting clip.
5. Slide the mounting clip over the rear of the unit until the clip is against the back of the panel. The mounting clip has latching features which engage into mating features on the CUB7P housing.
6. Note: It is necessary to hold the unit in place when sliding mounting clip into position.
7. Alternately tighten each screw to ensure uniform gasket pressure. Visually inspect the front panel gasket. The gasket should be compressed to about 75 to 80% of its original thickness. If not, gradually turn mounting screws to further compress gasket.
8. If the gasket is not adequately compressed and the mounting screws can no longer be turned, loosen mounting screws, and check that the mounting clip is latched as close as possible to the panel.
9. Repeat from step #5 for tightening mounting screws.

TROUBLESHOOTING

For further technical assistance, contact technical support at the appropriate company numbers listed.

LIMITED WARRANTY

The Company warrants the products it manufactures against defects in materials and workmanship for a period limited to two years from the date of shipment, provided the products have been stored, handled, installed, and used under proper conditions. The Company's liability under this limited warranty shall extend only to the repair or replacement of a defective product, at The Company's option. The Company disclaims all liability for any affirmation, promise or representation with respect to the products.

The customer agrees to hold Red Lion Controls harmless from, defend, and indemnify RLC against damages, claims, and expenses arising out of subsequent sales of RLC products or products containing components manufactured by RLC and based upon personal injuries, deaths, property damage, lost profits, and other matters which Buyer, its employees, or sub-contractors are or may be to any extent liable, including without limitation penalties imposed by the Consumer Product Safety Act (P.L. 92-573) and liability imposed upon any person pursuant to the Magnuson-Moss Warranty Act (P.L. 93-637), as now in effect or as amended hereafter.

No warranties expressed or implied are created with respect to The Company's products except those expressly contained herein. The Customer acknowledges the disclaimers and limitations contained herein and relies on no other warranties or affirmations.

L.S. INPUT; VOLTAGE VERSIONS (30 Hz MAX.)

The CUB7P3 accepts most machine control voltage signals. The input accepts single phase AC (50/60 Hz) or DC control voltages from 10 to 30 V at count speeds up to 30 Hz. The counter increments when voltage is applied between the LS input and Common. Any off-state leakage current may prevent the counter from operating properly.

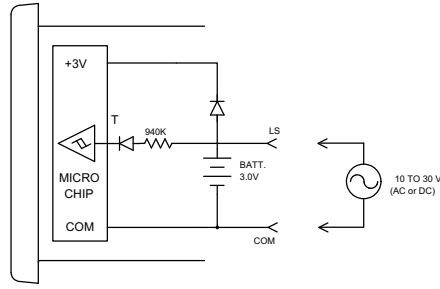

RESET AND PROGRAM OPTIONS

Connecting a wire from the RST EN (Reset Enable) or the HS (Program Enable) Input terminals to Common will enable the front panel Reset or Program buttons respectively.

Pulling the "RST." input low causes the counter to reset. The "RST." can be pulled low by either a mechanical switch or solid-state transistor switch. The Switch load is 15 μ A (max. voltage drop 0.5 V) when ON. The OFF-state leakage current must be less than 2 μ A.

Note: The RC protection circuit on the "RST." Input causes a delay of approximately 15 msec in Reset response.

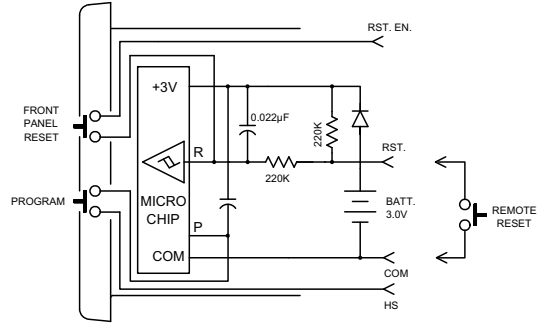

BACKLIGHT OPTION

Optional backlight versions of the CUB7P require an external 9 to 26 VDC power supply. The external supply is connected between the V+ and common terminals as shown in the drawing.

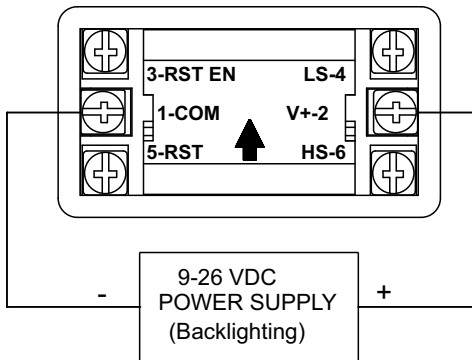

PROGRAMMING EXAMPLES

SCALING A COUNTER

Example: An encoder generates 600 pulses per foot. The Desired Display is tenths of inches. The Prescaler is determined using the formula below.

$$\text{Prescaler} = \frac{1 \text{ (inch)} \times 10 \text{ (Decimal Point Value)}}{600 \text{ pulses/foot} \times 1 \text{ foot} / 12 \text{ inches}}$$

Where:

Desired Display = The number of Desired Display units (revolutions, feet, 10ths of feet, meters, etc.).

Number of Pulses = The number of pulses required to achieve the Desired Display

Decimal Point Value = The desired decimal point placement on the display.

Decimal Point Value	Multiply By
0	1
0.0	10
0.00	100
0.000	1000
0.0000	10000
0.00000	100000

Example: Display tenths of inches when using

$$\text{Prescaler} = \frac{\text{Desired Display Units} \times \text{Decimal Point Value}}{\text{Number of Pulses}}$$

$$= 10/50 = 0.2$$

APPLICATION - TOTAL YARDS OF MATERIAL

The management at an amusement park wants to know how many miles (in tenths) each of their parking lot trams travel. They know that a 24 VDC input pulse is given for each revolution of the 6 foot in circumference wheel. The small CUB7P300 can meet this need. There are 5280 feet in one mile and with 6 feet per revolution; there would be 880 revolutions or pulses in a mile. To obtain the desired display of miles in tenths, the CUB7P300 decimal point would be programmed for 0.0 with the prescale value of 0.0114 (1 x 10 decimal point value / 880 pulses per mile). TO program these values, connect wires between RST EN (Reset Enable) and COM (Common); and between HS (Program Enable) and COM (Common) to enable the front panel push buttons. (See PROGRAMMING for more details) Remove these wires after programming to prevent the mileage from being reset.

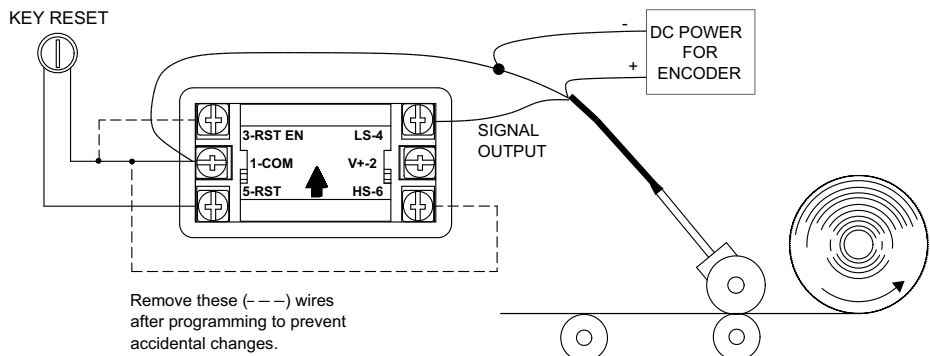

Remove these (---) wires after programming to prevent accidental changes.