

THIS DRAWING IS UNPUBLISHED. RELEASED FOR PUBLICATION .19  
 © COPYRIGHT 19 BY AMP INCORPORATED. ALL RIGHTS RESERVED.

LOC		DIST		REVISIONS			
P	LTR	DESCRIPTION		DATE	DWN	APVD	
AF	50	A	RELEASE TO PRODUCTION 063A-0273-99		30NOV99	MSF	KAR

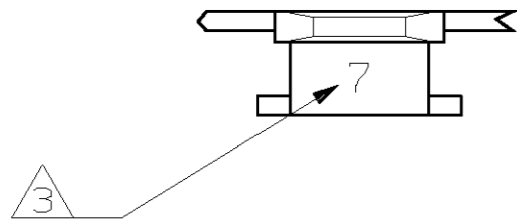

- 1 CONTINUOUS STRIP ON REELS WITH TERMINALS LOCATED ON 5.08±0.08 [.200±.003] CENTERS.
- 2 SLOT ACCEPTS 0.29-0.36mm [#29-#27] AWG COPPER MAGNET WIRE 2 WIRES MAX OF THE SAME SIZE PER SLOT.
- 3 IDENTIFICATION NUMBER 7 FOR WIRE SLOT SIZE.
- 4 0.00203 [.000080]-0.00381 [.000150] TIN PLATE OVER  
0.00127 [.000050]-0.00254 [.000100] NICKEL UNDERPLATE.

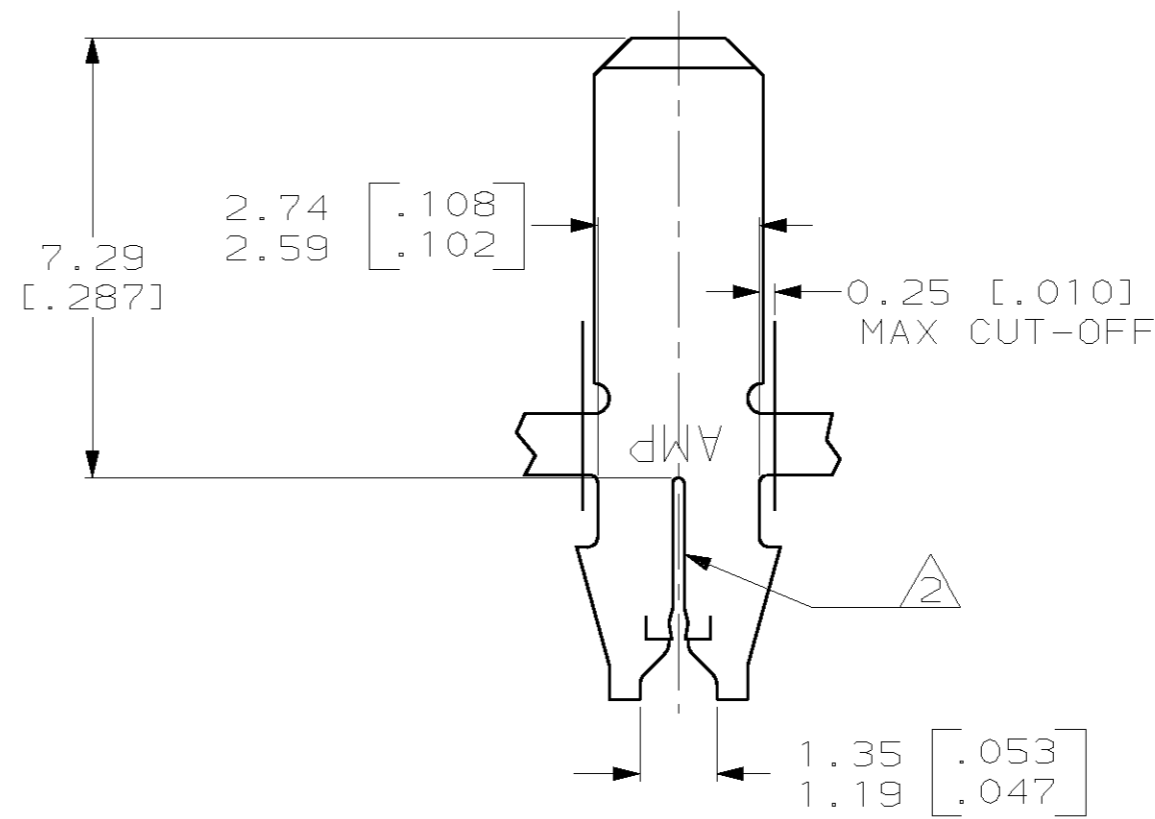
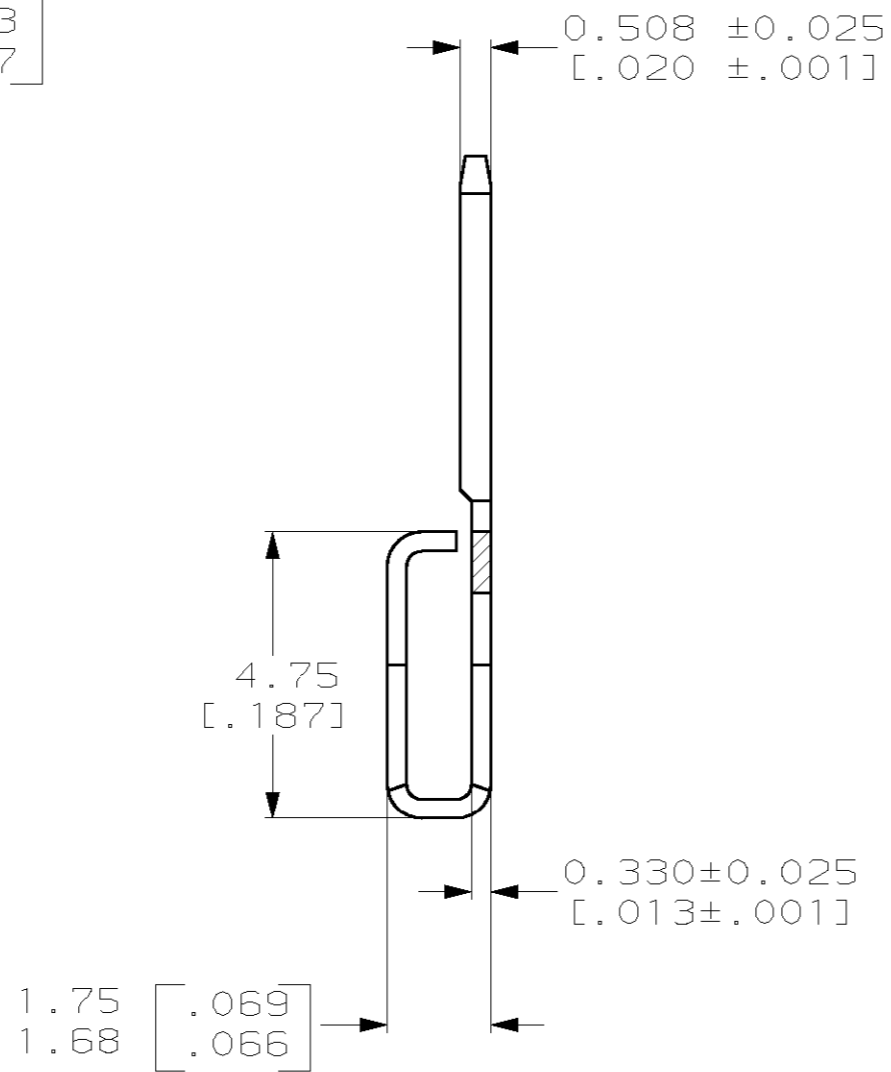
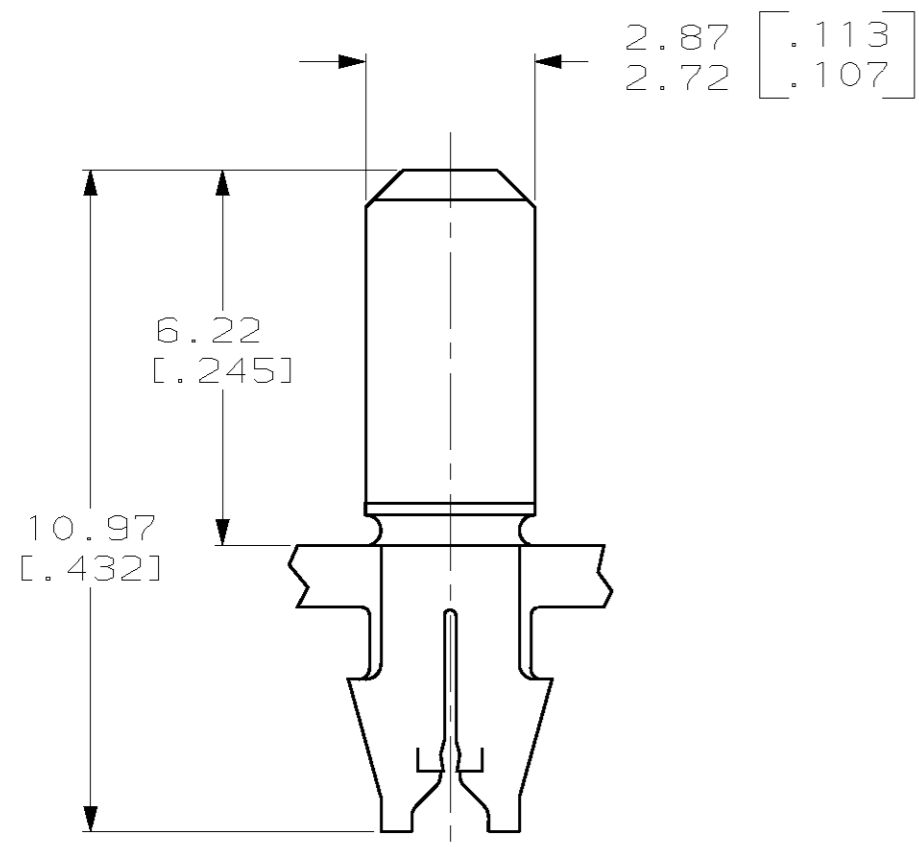

1217196-1  
PART NUMBER

THIS DRAWING IS A CONTROLLED DOCUMENT.		DWN MICHAEL S. FEHER 16AUG1999	AMP Incorporated Harrisburg, PA 17105-3608
DIMENSIONS: mm [INCHES]		CHK KURT A. RANDOLPH 16AUG1999	
TOLERANCES UNLESS OTHERWISE SPECIFIED: 0 PLC ±- 1 PLC ±- 2 PLC ±0.25 [.010] 3 PLC ±- 4 PLC ±- ANGLES ±- FINISH -		APVD KURT A. RANDOLPH 16AUG1999	
MATERIAL H03 PRE-MILLED BRASS		NAME KURT A. RANDOLPH	
		PRODUCT SPEC 108-2012	TAB, 2.79 [.110] FASTON™ 187 SERIES MAG-MATE™
		APPLICATION SPEC 114-2069	SIZE A2
		WEIGHT -	CAGE CODE 00779
		CUSTOMER DRAWING	DRAWING NO 1217196
		SCALE 8:1	RESTRICTED TO -
		SHEET 1 OF 1	REV A

1217196