

THIS DRAWING IS UNPUBLISHED.

RELEASED FOR PUBLICATION

ALL RIGHTS RESERVED.

© COPYRIGHT - By -

LOC AF DIST 50

REVISIONS

P	LTR	DESCRIPTION	DATE	DWN	APVD
	H	REVISED PER ECR-12-013518	23NOV2012	KH	PD

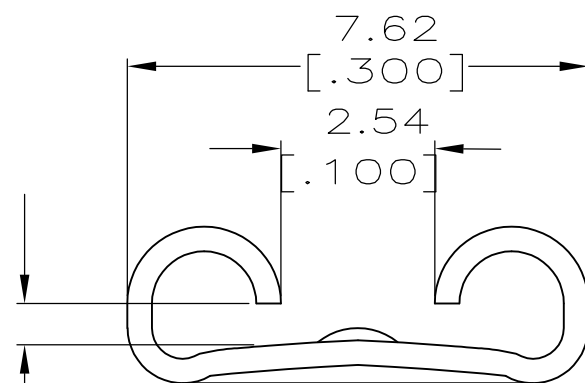
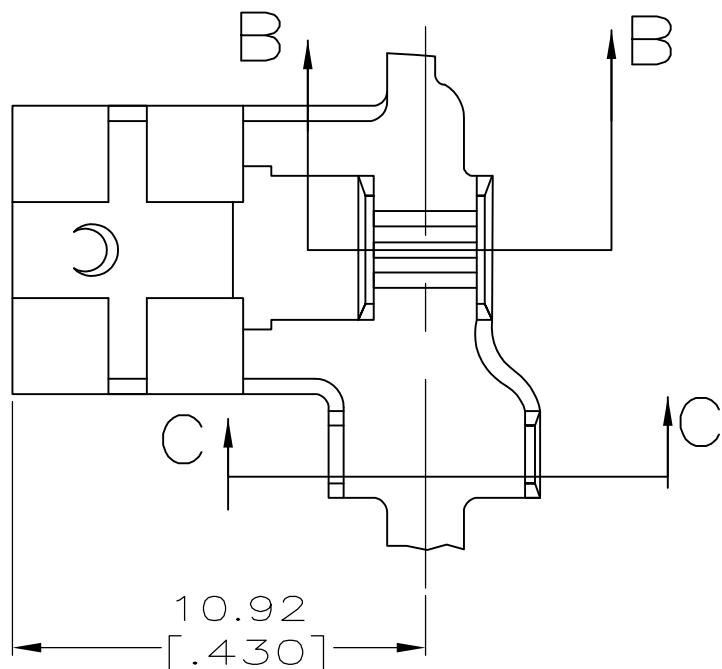

FITS .250 SERIES FASTON TAB

VIEW A-A SCALE 8:1

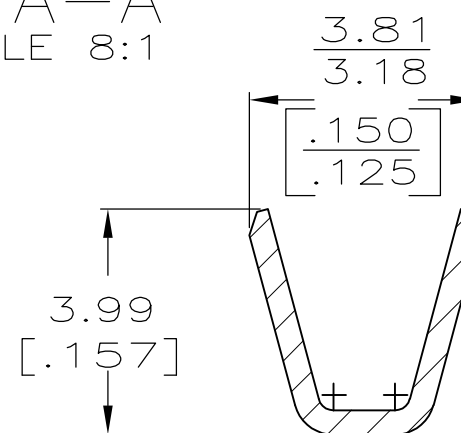
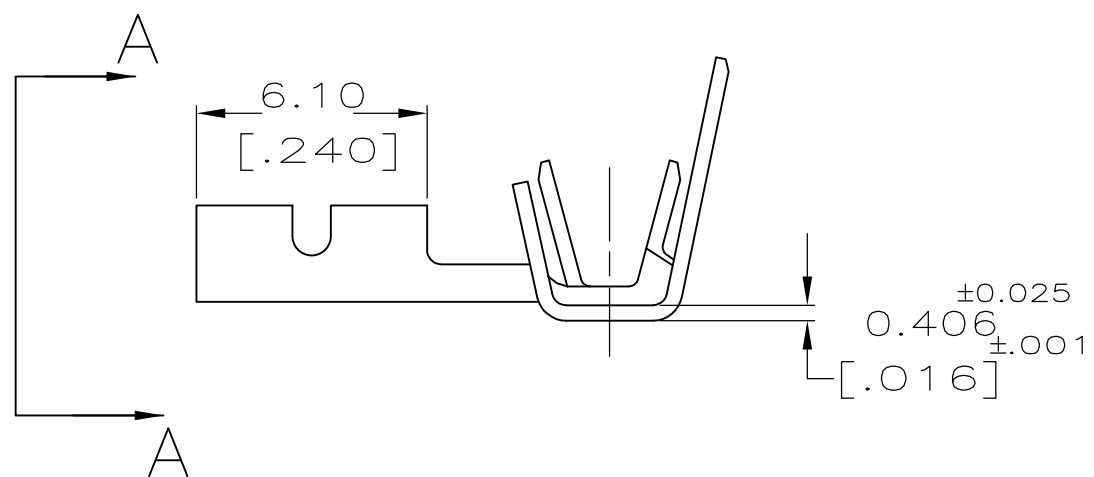

SECTION B-B SCALE 8:1

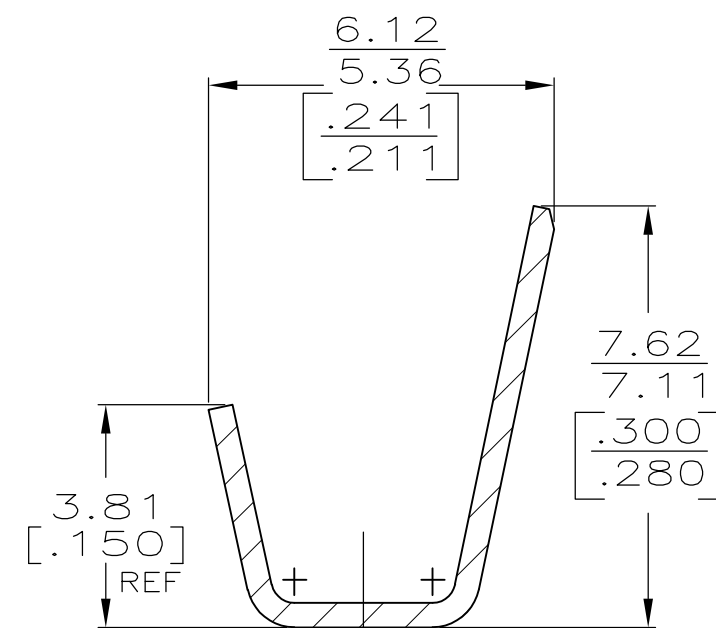

SECTION C-C SCALE 8:1

- 1 CONTINUOUS STRIP ON REELS
- 2 TIN 0.002032 [.000080] MIN THK PER MIL-T-10727
- 3 SPECIAL REELING
- 4 PRELIMINARY - NOT FOR PRODUCTION

OBSOLETE	-	2.79-5.08	[#18-#14]	0.813±0.025	3 4 63538-3
	TIN	[.110-.200]	TWO [#18'S]	[.032±.001]	
	-				63538-1
	FINISH	INSUL RANGE	WIRE SIZE	MATING TAB THICKNESS	PART NO

THIS DRAWING IS A CONTROLLED DOCUMENT.		DWN JR RUTH 7/31/89	TE Connectivity				
DIMENSIONS: mm [INCHES]		CHK MS FEHER 7/31/89					
TOLERANCES UNLESS OTHERWISE SPECIFIED:		APVD R KUZO 7/31/89	NAME				
0 PLC ± - 1 PLC ± - 2 PLC ± - 3 PLC ± 0.25 [.010] 4 PLC ± - ANGLES ± -		PRODUCT SPEC	RECPT, FASTON, FLAG, LOW-INSERTION, .250 SERIES				
MATERIAL BRASS		FINISH SEE TABLE	APPLICATION SPEC	SIZE	CAGE CODE	DRAWING NO	RESTRICTED TO
				A3	00779	C-63538	-
CUSTOMER DRAWING			WEIGHT -	SCALE 5:1	SHEET 1 OF 1	REV H	