

GROMMET NO.	GROMMET DASH NO.	"W"±.012 [0.3]	"H"±.008 [0.2]	"L" REF	"T" MAX	"T1" MAX	"DR" REMOVABLE PANEL HOLE DIA. RANGE	"DF" FIXED PANEL HOLE DIA. RANGE	MATING PLUNGER	ALTERNATE MATING PLUNGER NO.	PLUNGER DASH NO.
SLG	1L	.425 [10.8]	.079 [2]	.354 [9]	.063 [1.6]	.079-.165 [2-4.2]	.295-.303 [7.5-7.7]	.315-.323 [8-8.2]	SLPL	SLPB	1L
	2L										2L
	1M	.335 [8.5]	.071 [1.8]	.315 [8]	.043 [1.1]	.059-.146 [1.5-3.7]	.234-.240 [5.95-6.1]	.250-.256 [6.35-6.5]	SLPB	---	1M
	2M										2M
	3M										3M
	1S	.256 [6.5]	.047 [1.2]	.299 [7.6]	.039 [1]	.079-.158 [2-4]	.177-.181 [4.5-4.6]	.185-.189 [4.7-4.8]	SLPB	---	1S
	2S										2S

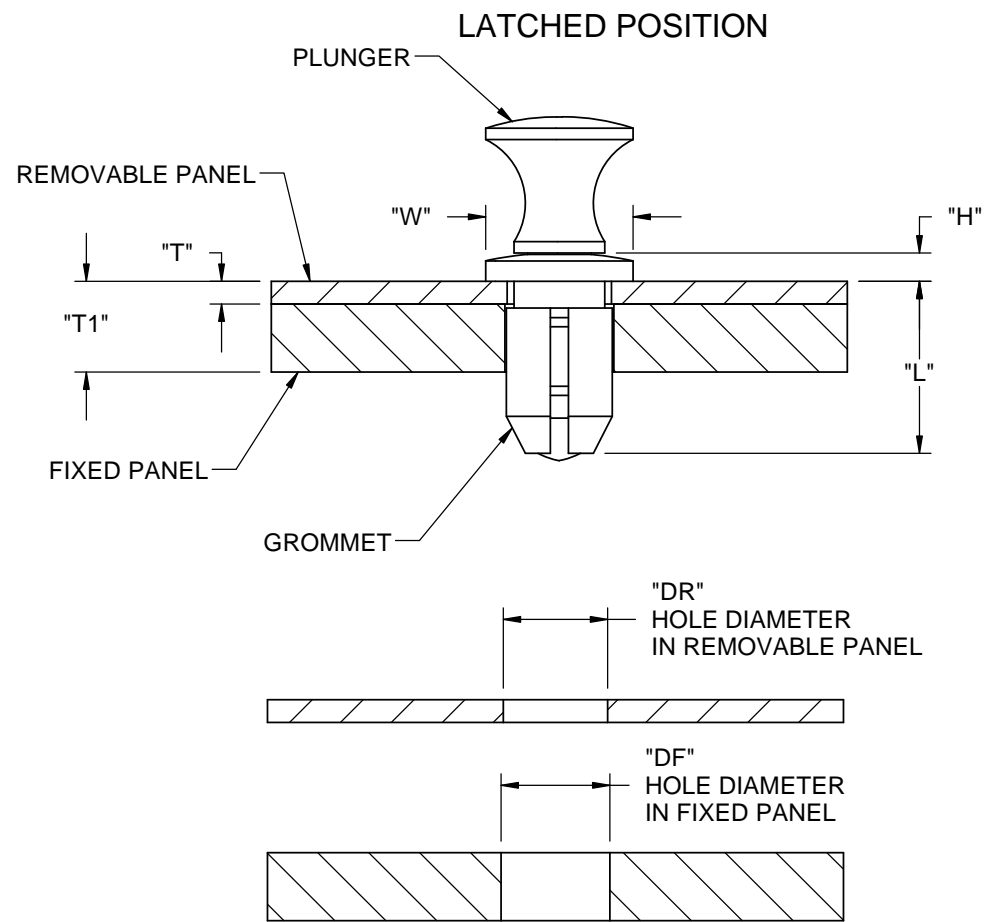

**PLUNGER STYLES**

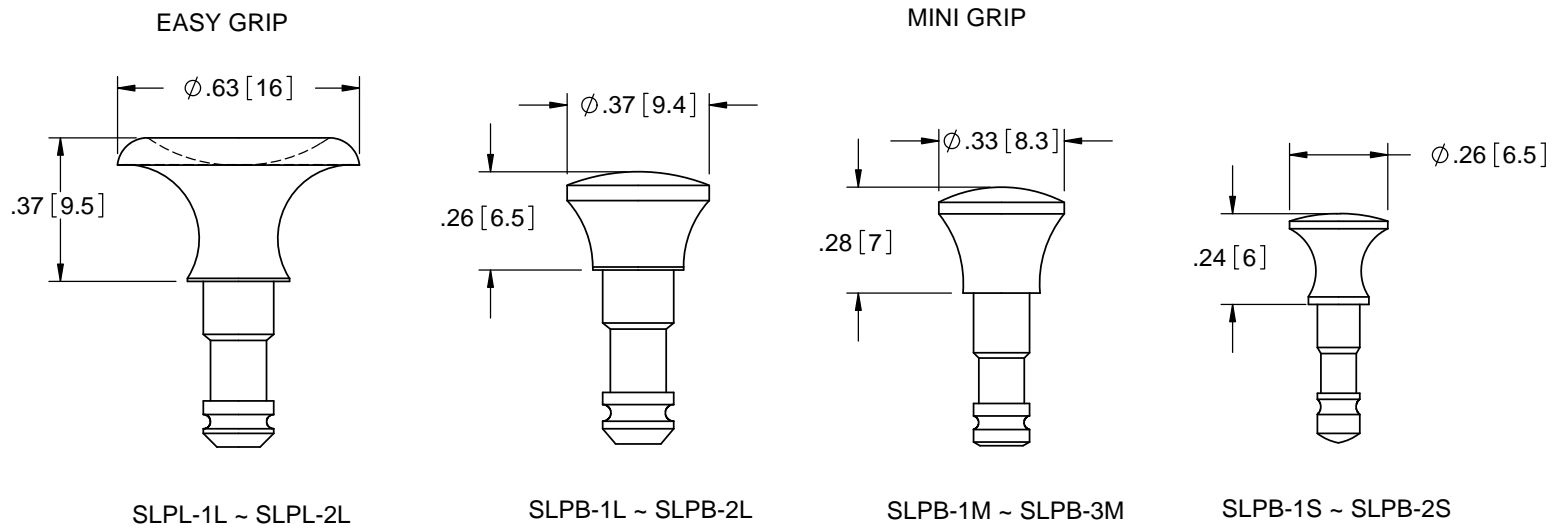

NOTES:  
 1. PLUNGER MATERIAL: NYLON 6, (RMS-120).  
 SLPB-2M MATERIAL: NYLON 6 (RMS-52)  
 2. GROMMET MATERIAL: POLYCARBONATE, (RMS-72).  
 3. COLOR: BLACK OR WHITE; ADD SUFFIX "-B" OR "-W" TO PART NO.

O	SEE CO 200747 FOR CHANGES	SK	01/12/2012
N	SEE CO 200725 FOR CHANGES	SK	10/11/11
M	SEE CO 200724 FOR CHANGES	SK	10/11/11
L	SEE CO 200604 FOR CHANGES	SK	12/01/10
K	SEE CO 200302 FOR CHANGES	SK	01/06/09
J	SEE CO 200187 FOR CHANGES	S.K.	05/21/08
I	SEE ECN #1157 FOR CHANGES	SJ	4/25/06
H	SEE ECN #944 FOR CHANGES	SK	02/22/05
-	SEE ENG. FOR REVISIONS A-G	-	---
REV.	DESCRIPTION	ENGR.	DATE

TITLE: <b>SNAP LATCH</b>				DWG IN IN [MM]	
CREATED USING SOLIDWORKS	FILE #: SL	DWN: SK	APP: SK	FINAL	
TOLERANCES UNLESS NOTED .XX=±.01 .XXX=±.005 FRAC.=±1/64 ANG.=±1°	SHEET: 1 OF 1   SHEET SIZE: B	DT: 02/22/05	CHKD: RDG	PART #	PRINT TYPE
RE: <b>RICHCO, INC.</b>				<b>RICHCO, INC.</b> ENG@RICHCO-INC.COM (773) 539-4060	<b>CA</b>
				<b>SEE TABLE</b>	