

RoHS compliant

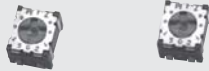

FEATURES

- RoHS compliant
- Compact and low-profile □2 mm single turn type
- Sealed construction

INTERNAL STRUCTURE

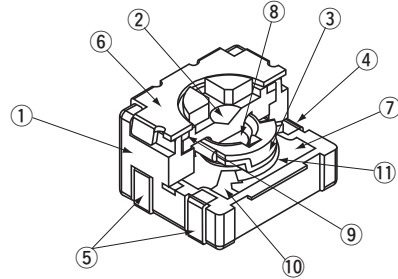

	Part name	Material	Flammability
①	Housing	Epoxy	UL 94V-0
②	Rotor	Polyphenylenesulphide	
③	Wiper	Stainless steel (SUS 304)	—
④	Terminal #2	Copper alloy, Sn-Cu-plated	
⑤	Terminal #1, #3		
⑥	Cover	Stainless steel (SUS 304)	
⑦	substrate	Ceramic	
⑧	Pin	Blass, Sn-plated	UL 94HB
⑨	“O” ring	Silicone rubber	
⑩	Terminations	Ag-Pd cermet	
⑪	Resistive element	RuO ₂ cermet	—

PART NUMBER DESIGNATION

ST-2 T A 100Ω (101)

Series name

Resistance code

Form of packaging

Resistance value

Taping (Reel)

Blank : Bulk in plastic bag

Product shape (Shape of terminal)

A : J-hook

※ Please refer to the LIST OF PART NUMBERS when placing orders.

ST-2

SURFACE MOUNT TRIMMERS

LIST OF PART NUMBERS

Adjustment position	Shape of terminal	Form of packaging	
		Taping (reel)	Plastic bag
Top adjustment	A (J-hook)	ST-2TA	ST-2A
Pieces in package		500 pcs./reel	100 pcs./pack

< Nominal resistance values >

100 Ω	200 Ω	500 Ω	1 kΩ	2 kΩ	5 kΩ	10 kΩ
20 kΩ	50 kΩ	100 kΩ	200 kΩ	500 kΩ	1 MΩ	

Fig.1

- ※The part numbers on the left are all available with the respective combination of <Nominal resistance values> (Fig. 1).
- ※Verify the above part numbers when placing orders.
- ※Taping version is not sold separately and must be purchased in reel units.

ELECTRICAL CHARACTERISTICS

Nominal resistance range	100 Ω ~ 1 MΩ
Resistance tolerance	± 20 %
Power ratings	0.1 W (70 °C) 0 W (125 °C)
Resistance law	(B) Linear law
Maximum input voltage	DC50 V or power rating, whichever is smaller
Maximum wiper current	($I = \sqrt{P/R}$ A) Within power ratings
Effective electrical angle	240 ° (1 turn)
End resistance	1 % or 2 Ω, whichever is greater
C.R.V.	2 % or 3 Ω, whichever is greater
Operating temp. range	-55 ~ 125 °C
Temp. coefficient	± 150 10 ⁻⁶ /°C
Insulation resistance	1000 MΩ minimum (DC500 V)
Dielectric strength	AC500 V, 60 s
Net weight	Approx. 0.032 g

MECHANICAL CHARACTERISTICS

Mechanical angle	270 ° (1 turn)
Operating torque	5 mN·m (51 gf·cm) maximum
Stop strength	8 mN·m (78.4 gf·cm) minimum
Rotational life	50 cycles [$\Delta R/R \leq \pm (2 \Omega + 5 \%)$]
Thrust to rotor	3 N (0.31 kgf) minimum
Solderability	245 ± 3 °C, 2 ~ 3 s
Shear (Adhesion)	5 N (0.51 kgf) 10 s
Substrate bending	Width 90 mm, bend 3 mm, 5 s, 1 time
Pull-off strength	5 N (0.51 kgf) 10 s

{ } : Reference only

ST-2

SURFACE MOUNT TRIMMERS

ENVIRONMENTAL CHARACTERISTICS

Test item	Test conditions	Specifications
Thermal shock	-65 ~ 125 °C (0.5 h), 5 cycles	[$\Delta R/R \leq 2\%$] [S.S. $\leq 2\%$]
Humidity	-10 ~ 65 °C (80 ~ 98 %), 10 cycles, 240 h	[$\Delta R/R \leq 2\%$]
Shock	981 m/s ² , 6 ms 6 directions for 3 times each	[$\Delta R/R \leq 2\%$] [S.S. $\leq 1\%$]
Vibration	(Amplitude) 1.52 mm or (Acceleration) 196 m/s ² , 10 ~ 2000 Hz, 3 directions, 12 times each	
Load life	70 °C, 0.1 W 1000 h	[$\Delta R/R \leq 3\%$] [S.S. $\leq 1\%$]
Low temp. operation	-55 °C, 2 h	[$\Delta R/R \leq 2\%$] [S.S. $\leq 2\%$]
High temp. exposure	125 °C, 250 h	[$\Delta R/R \leq 3\%$] [S.S. $\leq 2\%$]
Immersion seal	85 °C, 60 s	No leaks (No continuous bubbles)
Soldering heat	Reflow Peak temperature : 255 °C (Please refer to the profile below) Flow soldering : 260 ± 3 °C, 5 ~ 6 s, two times maximum Manual soldering : 350 ± 10 °C, 3 ~ 4 s	[$\Delta R/R \leq \pm 1\%$]

$\Delta R/R$: Change in total resistance
S.S. : Setting stability

MAXIMUM INPUT RATINGS

Nominal resistance values (Ω)	Resistance code	Maximum input voltage (V)	Maximum wiper current (mA)
100	101	3.16	31.6
200	201	4.47	22.4
500	501	7.07	14.1
1 k	102	10.0	10.0
2 k	202	14.1	7.1
5 k	502	22.3	4.5
10 k	103	31.6	3.2
20 k	203	44.7	2.2
50 k	503	50.0	1.0
100 k	104	50.0	0.5
200 k	204	50.0	0.25
500 k	504	50.0	0.1
1 M	105	50.0	0.05

Reflow profile for soldering heat evaluation

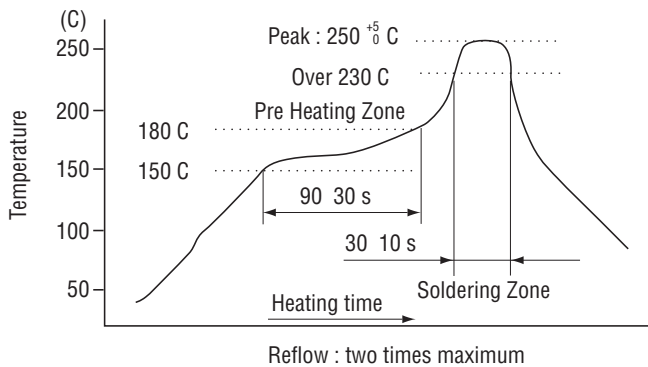

RECOMMENDED P.C.B. PAD OUTLINE DIMENSIONS

(Unit : mm)

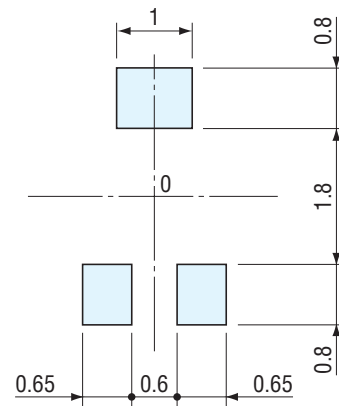

Note) The zero point is the center of mounting.

ST-2

SURFACE MOUNT TRIMMERS

OUTLINE DIMENSIONS

ST-2A

Top adjustment

Unless otherwise specified, tolerance : ± 0.3 (Unit : mm)

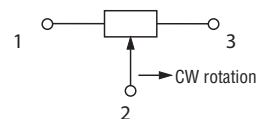

※ Note the terminal position.

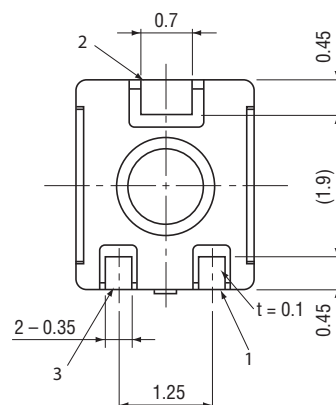
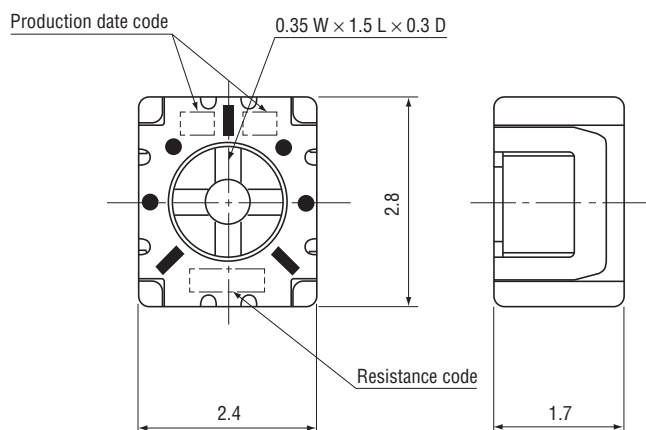

ST-2/ST-32 ADJUSTMENT TOOL

● Compliant with two models (ST-2/ST-32)

Recommended models	
ST-32	ST-2

Material : Polyoxymethylene

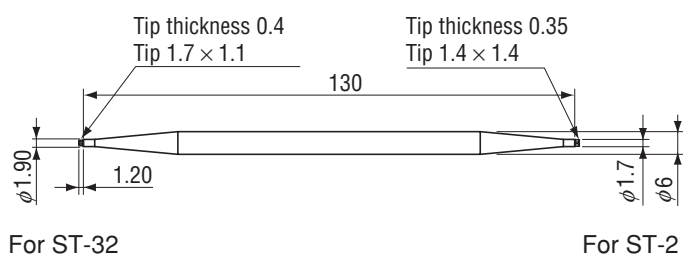

For ST-32

For ST-2

Recommended screwdrivers for use

Manufacturer	Model
ENGINEER INC.	DA-54

※ Note : Please do not use the tool for purposes other than adjustment of electronic components.

ST-2

SURFACE MOUNT TRIMMERS

PACKAGING SPECIFICATIONS

<Taping packaging specifications>

- Taping version is packaged in 500 pcs. per reel.
Orders will be accepted for units of 500 pcs., i.e., 500, 1000, 1500 pcs., etc.
- Taping version is boxed with one reel (500 pcs.).

Maximum number of consecutive missing pieces=2
Leader length and reel dimension are shown in the diagrams below.

EMBOSED TAPE DIMENSIONS

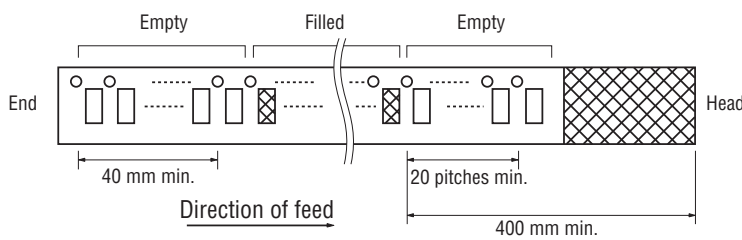

REEL DIMENSIONS

(Conforms to JIS C 0806-3)
(In accordance with EIAJ ET-7200A)

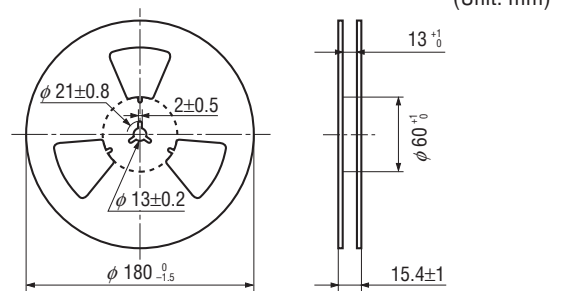

ST-2TA

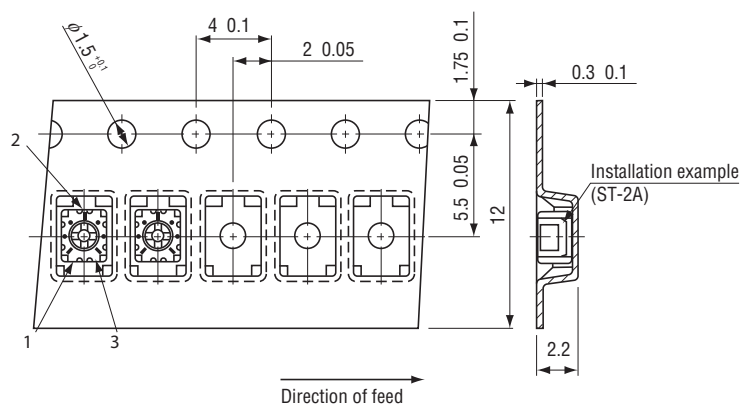

<Bulk pack specifications>

- Unit of bulk in a plastic bag is 100 pcs. per pack.
- Boxing of bulk in a plastic bag is performed with 500 pcs. per box.