

## Demonstration board kit for L638xE and L639x high voltage gate

Data brief

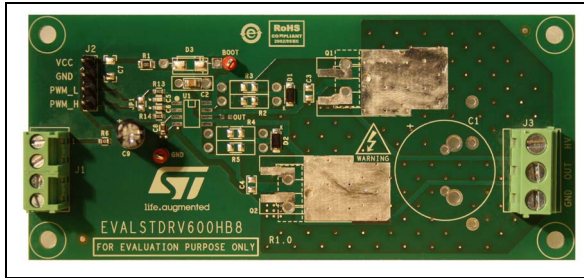

### Features

- Half-bridge configuration
- High voltage rail up to 600 V
- Includes samples of each compatible gate driver in SO8 package
  - L6385E, L6387E, L6388E, L6389E,
  - L6395, L6398, L6399
- Compatible with MOSFETs/IGBTs in
  - DPAK, D2PAK, TO-220, TO-220FP
- dV/dt transient immunity  $\pm 50$  V/ns in full temperature range
- Integrated bootstrap diode
- Dedicated high- and low-side driving inputs
- Compact and simplified layout
- Gate drivers in the kit features different functionalities and characteristics
  - UVLO on both - high-side and low-side
  - Internal deadtime, or no deadtime
  - Interlocking for anti cross-conduction protection
  - Ability to drive asymmetrical half-bridges and switched reluctance motors
  - Active high or active low LIN for single input gate driving

### Description

The L638xE and L639x are high voltage devices manufactured with the BCD™ “offline” technology. They are single chip half-bridge gate drivers for N-channel power MOSFET or IGBT.

The high-side (floating) section is designed to stand a voltage rail up to 600 V. The logic inputs are CMOS/TTL compatible down to 3.3 V for the easy interfacing microcontroller and up to 15 V for Hall-effect interfaces.

The integrated bootstrap diode allows a more compact and cost-effective design, but the use of the external diode is still possible in case of specific requirements.

The EVALSTDRV600HB8 contains 2 samples in the SO8 package for each of the compatible gate drivers, and allows evaluating all of the gate drivers features and functionalities while driving a half-bridge power stage based on N-channel MOSFETs or IGBTs in several different packages and with voltage rating up to 600 V.

Essential passive components such as the filtering and bootstrap capacitor are already mounted on the PCB, while the gate driving network shall be populated depending on the selected power switch.

Passive components footprints are compatible with both SMT and T.H. components, so they allow a fast and easy configuration and modification.

# 1 Supported devices

The EVALSTDRV600HB8 board supports several high voltage high- and low-side driver devices all in the SO8 package.

**Table 1. Supported devices and characteristics**

Part name	Max. supply voltage	Current capability sink/source	3.3 V compatible inputs	UVLO on V <sub>CC</sub>	UVLO on V <sub>BO</sub>	Deadtime	Interlocking
L6385ED	17 V	650 mA 400 mA	NO	ON 9.6 V OFF 8.3 V	ON 9.5 V OFF 8.2 V	NO	NO
L6387ED	17 V	650 mA 400 mA	NO	ON 6.0 V OFF 5.5 V	NO	NO	YES
L6388ED	17 V	650 mA 400 mA	YES	ON 9.6 V OFF 8.3 V	ON 9.5 V OFF 8.2 V	320 ns	YES
L6389ED	17 V	650 mA 400 mA	YES	ON 9.6 V OFF 8.3 V	ON 9.5 V OFF 8.2 V	470 ns	YES
L6395D	20 V	430 mA 290 mA	YES	ON 9.5 V OFF 8.8 V	ON 8.6 V OFF 8.0 V	NO	NO
L6398D <sup>(1)</sup>	20 V	430 mA 290 mA	YES	ON 9.5 V OFF 8.0 V	ON 9.0 V OFF 8.0 V	320 ns	YES
L6399D	20 V	430 mA 290 mA	YES	ON 9.5 V OFF 8.0 V	ON 9.0 V OFF 8.0 V	320 ns	YES

1. LIN input active low, allows single input driving configuration.

## 2 Schematic diagram

Figure 1. EVALSTDRV600HB8 circuit schematic

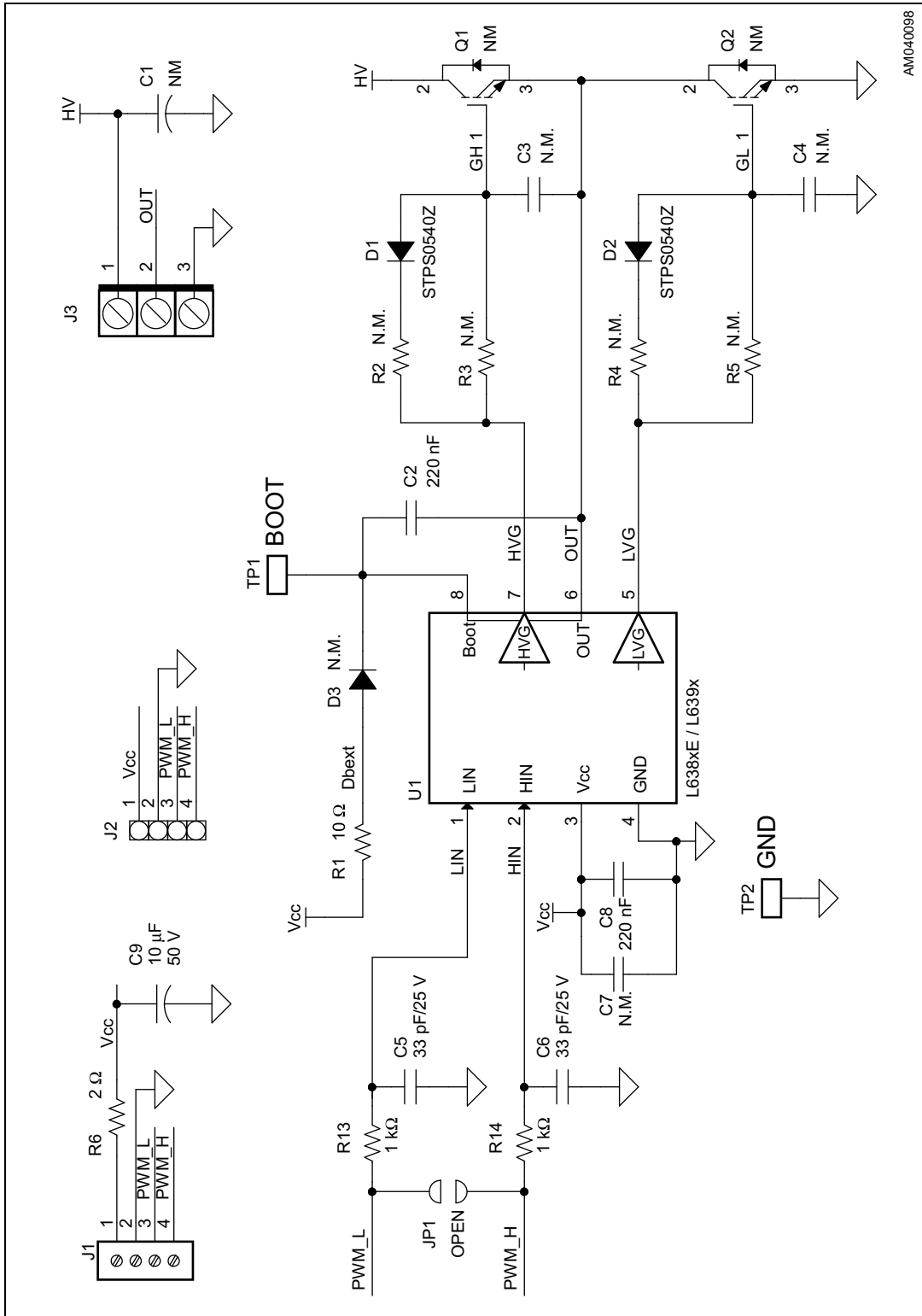

AM040098

### 3 Bill of material

**Table 2. EVALSTDRV600HB8 - bill of material**

Part reference	Part value	Part description
C1	N.M.	Electrolytic capacitor, D18, P7.62
C2	220 nF / 50 V	Ceramic capacitor, SMT 0805 (or 2.5 x 7.5 P05)
C3, C4	N.M.	Ceramic capacitor, SMT 0805
C5, C6	33 pF / 25 V	Ceramic capacitor, SMT 0603
C7	N.M.	Ceramic capacitor, SMT 1206
C8	220 nF / 50 V	Ceramic capacitor, SMT 0603
C9	10 $\mu$ F / 50 V	Electrolytic capacitor, D5, P2.5
D1, D2	STPS0540Z	Schottky diode 40 V, 0.5 A, SOD-123
D3	N. M.	DO41 or SMA
J1	MORSV350-4P	PCB terminal block 3.50 mm, 4 POS
J2	STRIP254P-M-4	Male pin strip 2.54 mm, 4 POS
J3	MORSV508-3P	PCB terminal block 5.08 mm, 3 POS
Q1, Q2	N. M.	Power MOSFETs or IGBTs, DPAK, D2PAK, or TO220
R1	10 $\Omega$	Resistor, SMT 0805
R2, R3, R4, R5	N.M.	Resistor, SMT 0805 or T.H. P10
R6	2 $\Omega$	Resistor, SMT 0603
R13, R14	1 k $\Omega$	Resistor, SMT 0603
TP1, TP2	TPTH-RING-1MM	PCB test terminal 1 mm
U1	N.M.	600 V high- and low-side gate driver, SO8

# 4 Layout and component placements

Figure 2. EVALSTDRV600HB8 - layout (top layer)

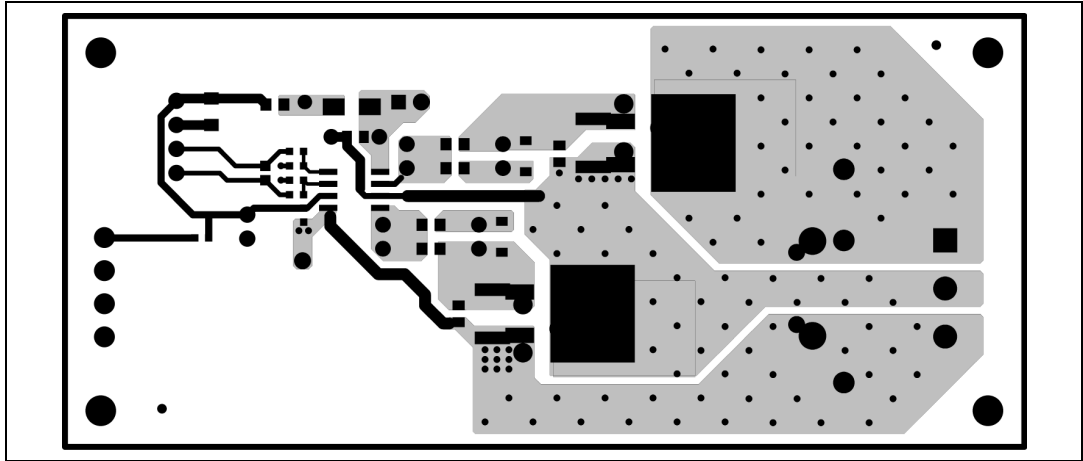

Figure 3. EVALSTDRV600HB8 - Layout (bottom layer)

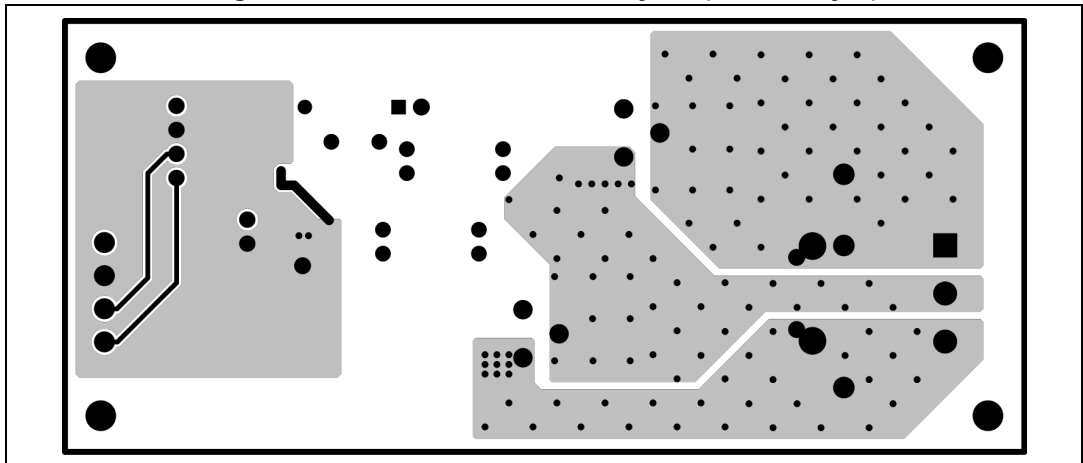
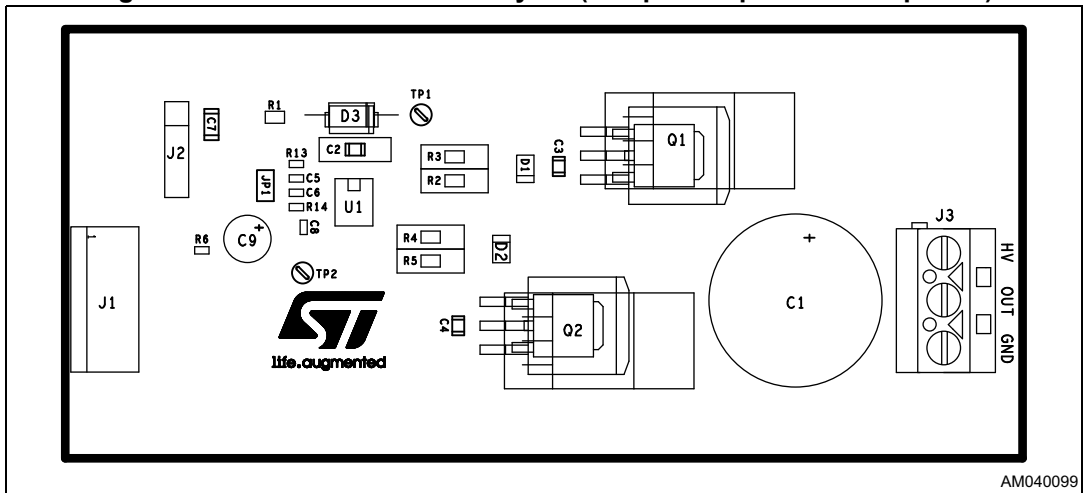

Figure 4. EVALSTDRV600HB8 - layout (component placement top view)



AM040099

## 5 Revision history

Table 3. Document revision history

Date	Revision	Changes
28-Apr-2017	1	Initial release.

**IMPORTANT NOTICE – PLEASE READ CAREFULLY**

STMicroelectronics NV and its subsidiaries ("ST") reserve the right to make changes, corrections, enhancements, modifications, and improvements to ST products and/or to this document at any time without notice. Purchasers should obtain the latest relevant information on ST products before placing orders. ST products are sold pursuant to ST's terms and conditions of sale in place at the time of order acknowledgement.

Purchasers are solely responsible for the choice, selection, and use of ST products and ST assumes no liability for application assistance or the design of Purchasers' products.

No license, express or implied, to any intellectual property right is granted by ST herein.

Resale of ST products with provisions different from the information set forth herein shall void any warranty granted by ST for such product.

ST and the ST logo are trademarks of ST. All other product or service names are the property of their respective owners.

Information in this document supersedes and replaces information previously supplied in any prior versions of this document.

© 2017 STMicroelectronics – All rights reserved