

1. INTRODUCTION

This instruction sheet provides instructions on product application and a maintenance and inspection procedure for crimping dies 68312-1 and 68313-1 used in machine 68250-1.

These dies crimp SOLISTRAND terminals on solid or stranded copper wire sizes 8 and 6.

Dies are coated with preservative to prevent rust and corrosion. Wipe preservative from dies, particularly from crimping surfaces.

Section 2 of this publication, "INSTRUCTIONS", provides personal safety, die installation and wire preparation information. Section 3 features a terminal and splice "CRIMP INSPECTION" procedure. Section 4 contains a "MAINTENANCE AND INSPECTION PROCEDURE" which will enable you to establish and maintain a die certification program.

For further instructions relative to the machine, tooling adjustment, tape loading, etc., refer to instructions packaged with the machine.



NOTE

Dimensions are in metric units with [inches in brackets]. Figures and illustrations are for reference only and are not drawn to scale.

2. INSTRUCTIONS



DANGER

Avoid personal injury. Always disconnect machine from power supply when performing adjustments, die installation or removal, and machine maintenance. Always keep guards and covers in place during normal machine operation.

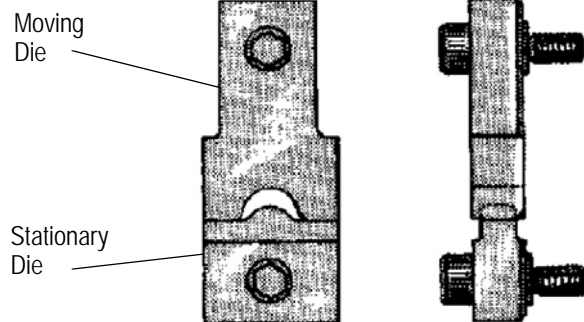

WIRE SIZE	DIE PART NUMBER	STRIP LENGTH	
		MIN	MAX
8	68312-1	8.33 [.328]	9.12 [.359]
6	68313-1	9.93 [.391]	10.72 [.422]

Figure 1

2.1. Die Installation

1. Refer to the table in Figure 1 and select the die number for the wire size being used. Wire size displayed on dies must match wire size stamped under terminal tongue.
2. **TURN OFF MAIN POWER SWITCH**, disconnect machine from power supply.
3. Remove front applicator guard, then depress terminal extractor, (see Figure 2), and pivot it away from crimping die holder.
4. With tape release lever "up", insert moving (upper) die into die holder and tighten holding screw. See Figure 2.
5. Insert stationary (lower) die into die holder and tighten holding screw. See Figure 2.
6. Pivot terminal extractor to vertical position and reinstall applicator guard.
7. Lower tape release lever.
8. Connect machine to power supply and turn on main power switch.

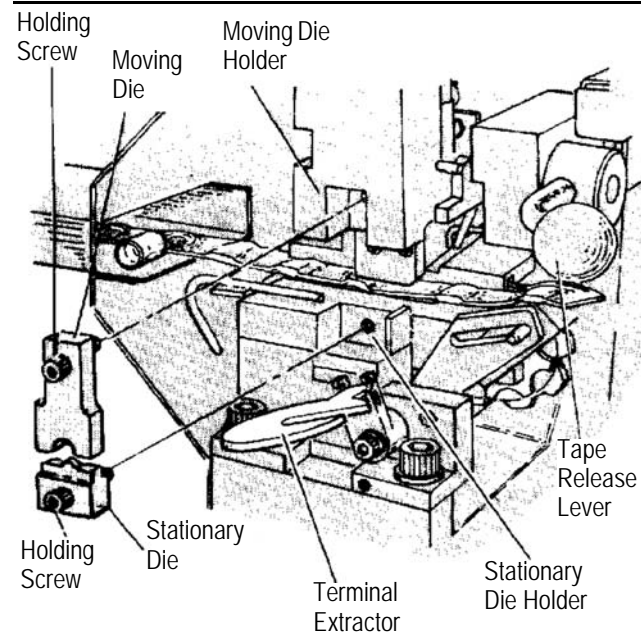

Figure 2

2.2. Die Removal

1. **TURN OFF MAIN POWER SWITCH**, disconnect machine from power supply.
2. Remove front applicator guard, then depress terminal extractor and pivot it away from crimping die holder.

3. With tape release lever “up”, remove holding screws and dies.

2.3. Wire Preparation and Crimp Instructions

1. Select the correct wire strip length from Figure 1. Do NOT use wires with nicked or missing conductor strands.
2. Place main power switch in the ON position and be sure tape release lever is lowered.
3. Insert stripped wire conductor into terminal wire barrel until it butts against the stop, see Figure 3.
4. Depress and release foot switch. The machine will cycle and crimp the terminal.
5. Remove crimped terminal.
6. Repeat steps (3) thru (5) for each terminal to be crimped.
7. Refer to Section 3 and Figure 4 for “Crimp Inspection” procedure.

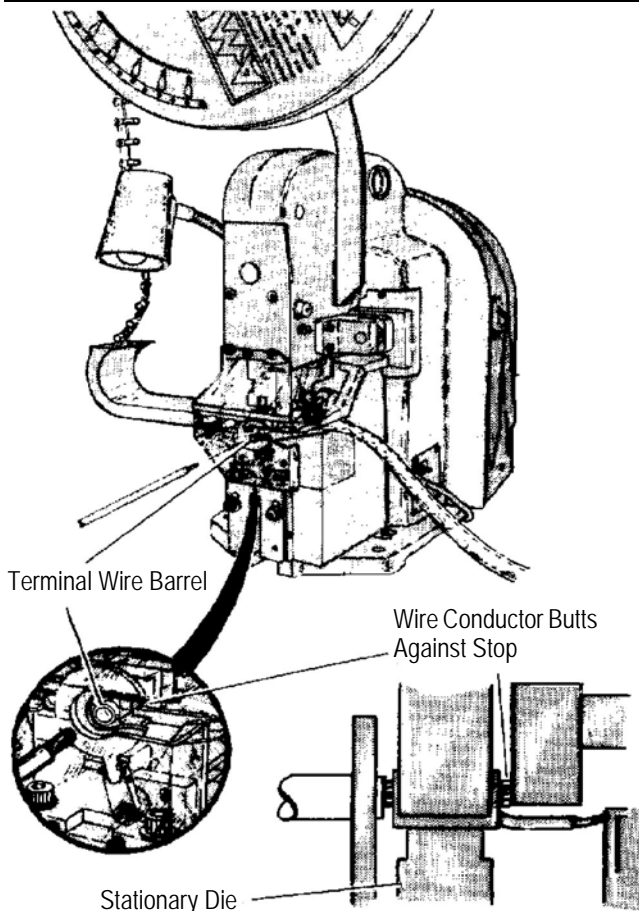

Figure 3

3. CRIMP INSPECTION

Inspect crimped terminals by checking the features described in Figure 4.

Use only the terminals that meet the conditions shown in the “ACCEPT” column. “REJECT” terminals can be avoided through careful use of instructions provided in the machine manual and by performing regular die maintenance as instructed in Section 4.

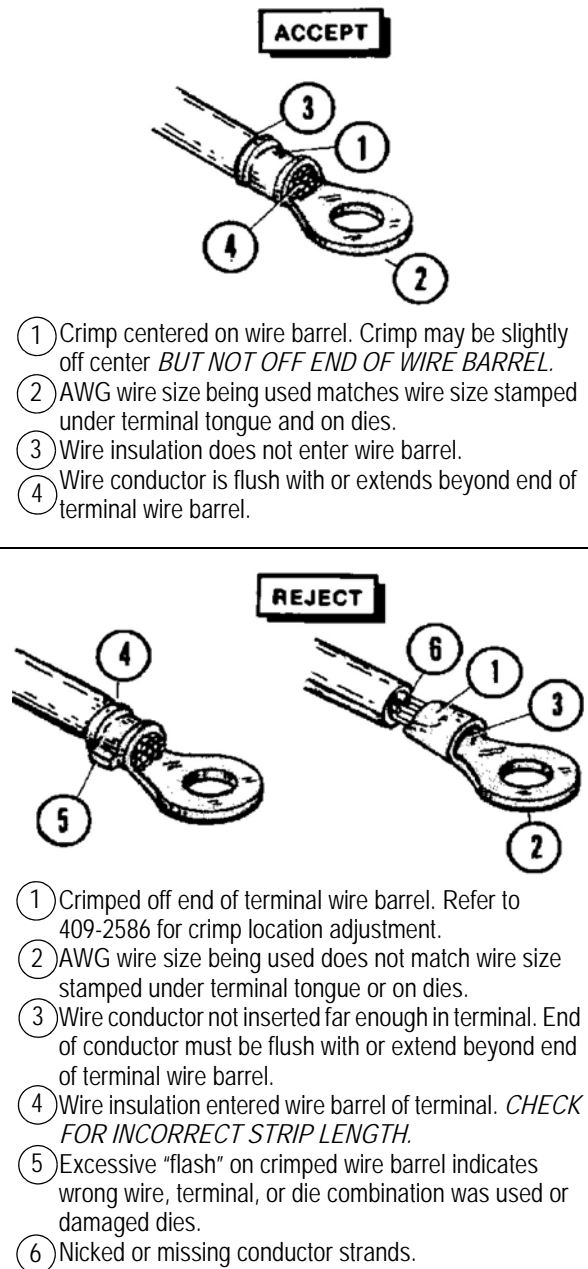

Figure 4

4. MAINTENANCE / INSPECTION PROCEDURE

TE Connectivity recommends that a maintenance and inspection program be performed periodically to ensure dependable and uniform terminations. Dies should be inspected at least once a month. Frequency of inspection may be adjusted to suit your requirements through experience. Frequency of inspection is dependent upon:

- The card, amount of use, and handling of the dies.
- The degree of operator skill.
- The presence of abnormal amounts for dust and dirt.
- Your own established standards.

All dies are thoroughly inspected before packaging. Since there is a possibility of die damage in shipment, new dies should be inspected in accordance with Section 4 when received in your plant.

4.1. Cleaning

Do NOT allow deposits of dirt, grease, and foreign matter to accumulate in the die closure surfaces and on the bottoming surfaces of the dies. These deposits may prevent the dies from bottoming fully and may also cause excessive wear in the die closure surfaces, thereby affecting the quality of the crimp. The dies should be wiped clean frequently with a clean cloth.

4.2. Visual Inspection

Visually inspect the die closure surfaces for chipped or pitted conditions. Although dies may gage within permissible limits, worn or damaged die closure surfaces are objectionable and can affect the quality of the crimp. Examples of possible damaged die closure surfaces are shown in Figure 5.

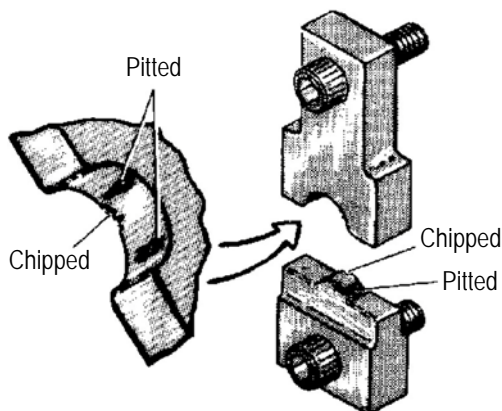

Figure 5

4.3. Die Closure Inspection

Every die is inspected and tested for proper die closure before packaging. An inspection should be performed periodically to check the die closure for excessive wear.

Die closure inspection is accomplished using GO / NO-GO plug gages. TE neither manufactures nor sells plug gages. A suggested plug gage design and the GO / No-GO dimensions of the plug gage members are listed in Figure 6. The following procedure is recommended for inspecting the die closures.

1. Clean oil or dirt from the die closure surfaces, bottoming surfaces, and plug gage members.

Suggested Plug Gage Design

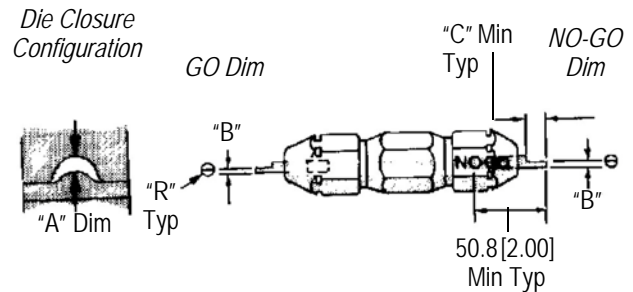

TOOL NO.	DIE CLOSURE DIM'S "A"†		GAGE MEMBER‡ DIM'S "B"		"C"	"R"
	GO	NO-GO	GO	NO-GO		
68312-1	2.540 [.1000]	2.692 [.1060]	2.540-2.548 [.1000-.1003]	2.690-2.692 [.1059-.1060]	7.92 [.312]	3.581 [.1410]
68313-1	3.150 [.1240]	3.302 [.1300]	3.150-3.157 [.1240-.1243]	3.299-3.302 [.1299-.1300]	9.52 [.375]	4.496 [.1770]

†Die closure dimensions apply when dies are bottomed but not under pressure.
‡Material - Tool steel.

Figure 6

2. Assemble dies so they are bottomed but not under pressure. See Figure 7A.

3. With dies bottomed, inspect the die closure using the proper plug gage. Hold gage in straight alignment with the die closure and carefully try to insert without forcing, the GO member. See Figure 7B. the GO member must pass completely through the die closure. Try to insert the NO-GO member. The NO-GO member may enter partially, but must not pass completely through the die closure.

4. If the dies meet GO / NO-GO gage conditions, the dies are dimensionally correct.

5. If dies do not meet the GO / NO-GO gage conditions, contact your local TE Representative.

Inspection of Die Closure

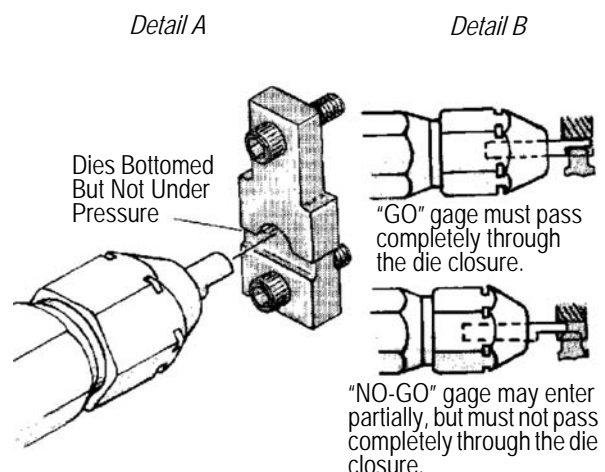

Figure 7

4.4. Replacement Parts

Die sets and die replacement parts, see Figure 8, can be purchased from TE.

5. REVISION SUMMARY

- Updated document to incorporate requirements
- Deleted product trademark name in all instances

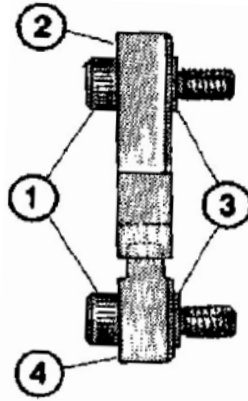

ITEM NUMBER	DESCRIPTION	QTY PER SET	DIE SET NUMBERS AND COMPONENT PART NUMBERS	
			88312-1	88313-1
1	SCREW	2	1-59781-2	59781-9
2	MOVING DIE	1	308983-2	308983-1
3	RING, Retaining	2	1-21046-3	1-21046-3
4	STATIONARY DIE	1	308984-2	308984-1

Figure 8