

LOC	DIST	REVISIONS				
G	14	ZONE	LTR	DESCRIPTION	DATE	APPD
			B	REV, RDRW, & SM PKG PER 0720-0040-93	3-26-93	JL DAP

METRIC
 DIMENSIONS LISTED IN mm [INCHES]

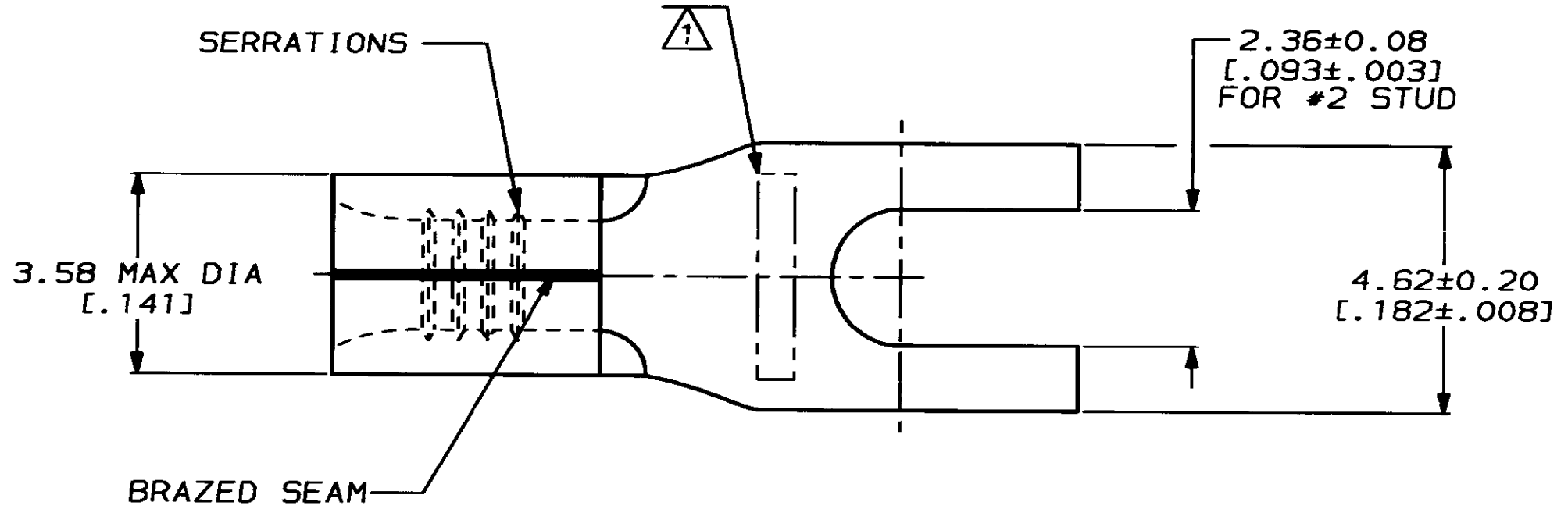

AMP WIRE RANGE	E13288 Listed
22-16 AWG SOLID OR STRANDED	22-16 AWG SOLID OR STRANDED
LR7189 Certified	MILITARY P/N AND CLASS
22-16 AWG SOLID OR STRANDED	NOT APPLICABLE

△ STAMP AMP 22-18* APPROX AS SHOWN
 22-16 TERMINALS ARE STAMPED 22-18 IN
 ACCORDANCE WITH MILITARY SPECIFICATION
 MIL-T-7928, COMMERCIAL WIRE RANGE IS 22-16

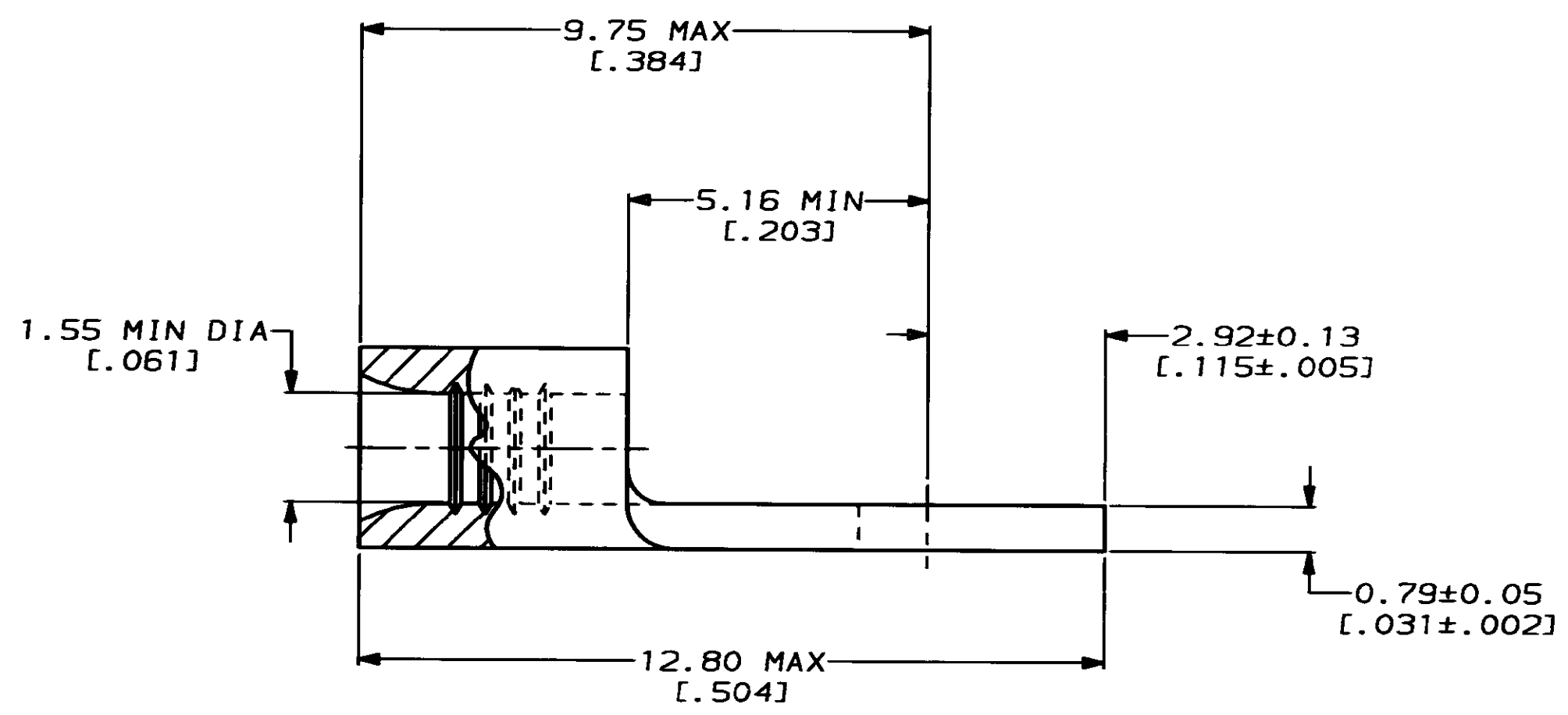

100	LOOSE PIECE, BOX	8-53555-1
5000	ON TAPE	53555-2
---	LOOSE PIECE	53555-1
QUANTITY	PACKAGING TYPE	PART NO

AMP INCORPORATED CUSTOMER SERVICE SYSTEMS		MAX RECOMMENDED OPERATING TEMPERATURE: 170°C MAX	DO NOT SCALE PRINT. UNLESS SPECIFIED DIMENSIONS IN mm [INCHES] TOLERANCES ON: 2 PLC DEC ± - 3 PLC DEC ± - ANGLES ± -	DR 3-26-93 TA BRINKMAN CHK 3-26-93 DA PATTERSON APPD 3-26-93 DE MILLER APPD 3-26-93 JL MECKLEY PRODUCT SPEC APPLICATION SPEC WEIGHT -	AMP AMP Incorporated Harrisburg, PA 17105-3608
FOR ADDITIONAL PRODUCT INFORMATION OR COPIES OF DRAWINGS AND TECHNICAL DOCUMENTS	PRODUCT INFORMATION CENTER 1-800-522-6752	VOLTAGE RATING: NOT APPLICABLE	MATERIAL COPPER PER ASTM B-152 ANNEALED		NAME TERMINAL, SPADE TONGUE, SOLISTRAND™
FOR APPLICATION TOOLING INFORMATION	TOOLING ASSISTANCE CENTER 1-800-722-1111	WIRE CROSS SECTIONAL AREA RANGE: 0.26-1.65mm ² [509-3,260] CIR MILS SOLID OR STRANDED	FINISH TIN PLATE 0.00254 [.000100] MIN THK PER MIL-T-10727		SIZE CAGE CODE DRAWING NO C 00779 C-53555
FOR ORDER ENTRY	1-800-526-5142	THIS DRAWING IS A CONTROLLED DOCUMENT FOR AMP INCORPORATED. IT IS SUBJECT TO CHANGE AND THE CONTROLLING ENGINEERING ORGANIZATION SHOULD BE CONTACTED FOR THE LATEST REVISION.			SCALE 10:1 SHEET 1 OF 1