

SECTION A-A

SECTION B-B

spec ref	-	dr	De-Ming Lu	2013/10/10	projection	MM	size	A2	scale	3:1	
tolerance std	ASME Y14.5	eng	Sunny2 Liu	2016/05/10			ecn no	ELX-DG-24036-1			
TOLERANCES UNLESS OTHERWISE SPECIFIED		chr	Terris Liu	2016/05/20			rel level	Released			
surface	linear	appr	Pai-Ming Zheng	2016/05/24	product family	CARD EDGE	rel level	Released			
ASME Y14.5	angular	0°	±0.5	±0.25	±0.10	±2°	title	SMT REC (20P+8S) OMIT 8P			
							HPCE - (STRADDLE MOUNT)	cat. no.	-	Product - Customer Drw	
							rel level	10127593		rev	C
										sheet 1 of 4	

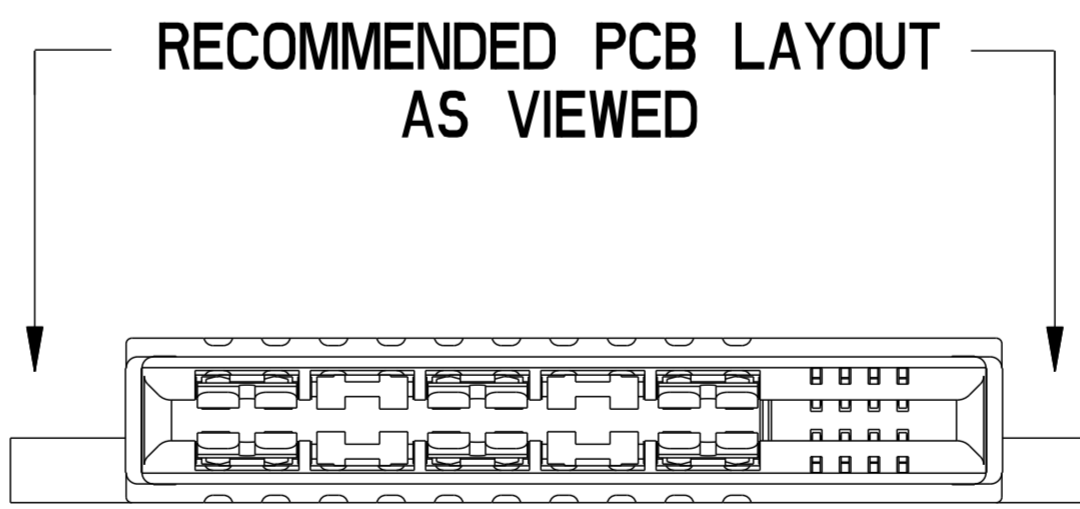
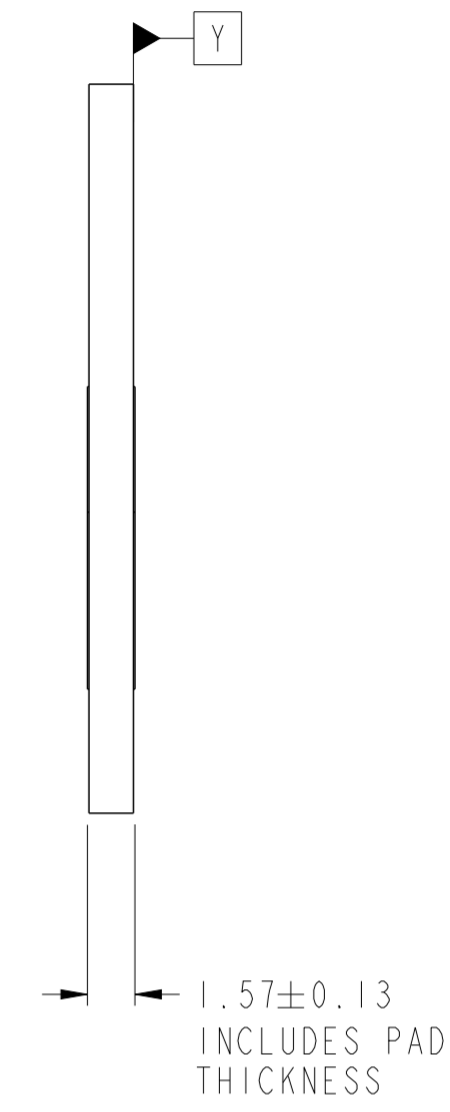
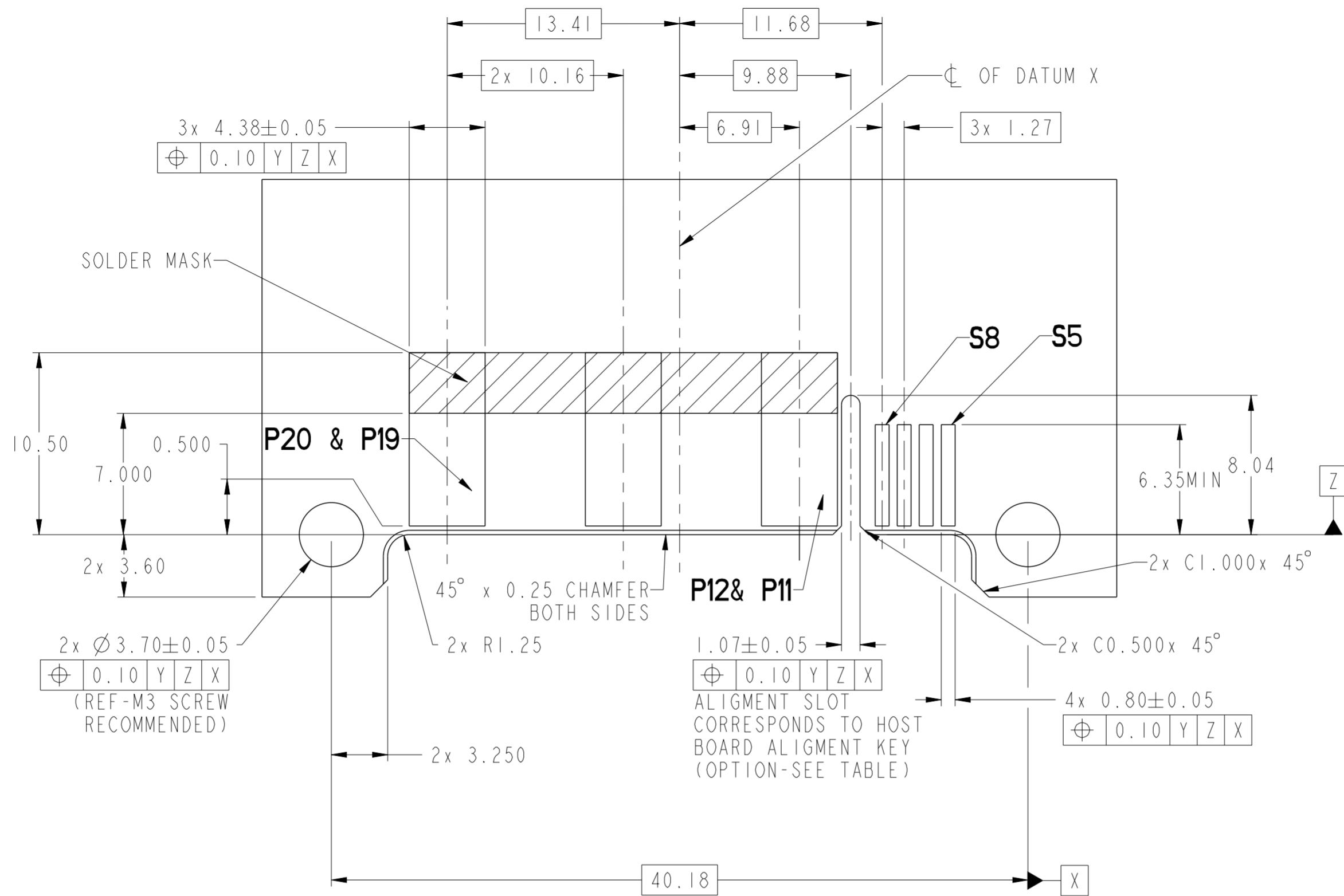

spec ref	-	dr	De-Ming Lu	2013/10/10	projection	MM	size	A2	scale	3:1	
tolerance std	ASME Y14.5	eng	Sunny2 Liu	2016/05/10		CARD EDGE	ecn no	ELX-DG-24036-1			
TOLERANCES UNLESS OTHERWISE SPECIFIED		chr	Terris Liu	2016/05/20			rel level	Released			
surface	ASME Y14.5	appr	Pai-Ming Zheng	2016/05/24			product family	SMT REC (20P+8S) OMIT 8P HPCE - (STRADDLE MOUNT)			
linear	0.X ±0.5 0.XX ±0.25 0.XXX ±0.10	Amphenol FCI	title		cat. no.	Product - Customer Drw	sheet 2 of 4	rev	C		
angular	0° ±2°	PDS: Rev :C		STATUS:Released		Printed: May 24, 2016					

Amphenol FCI

© 2016 AFCI

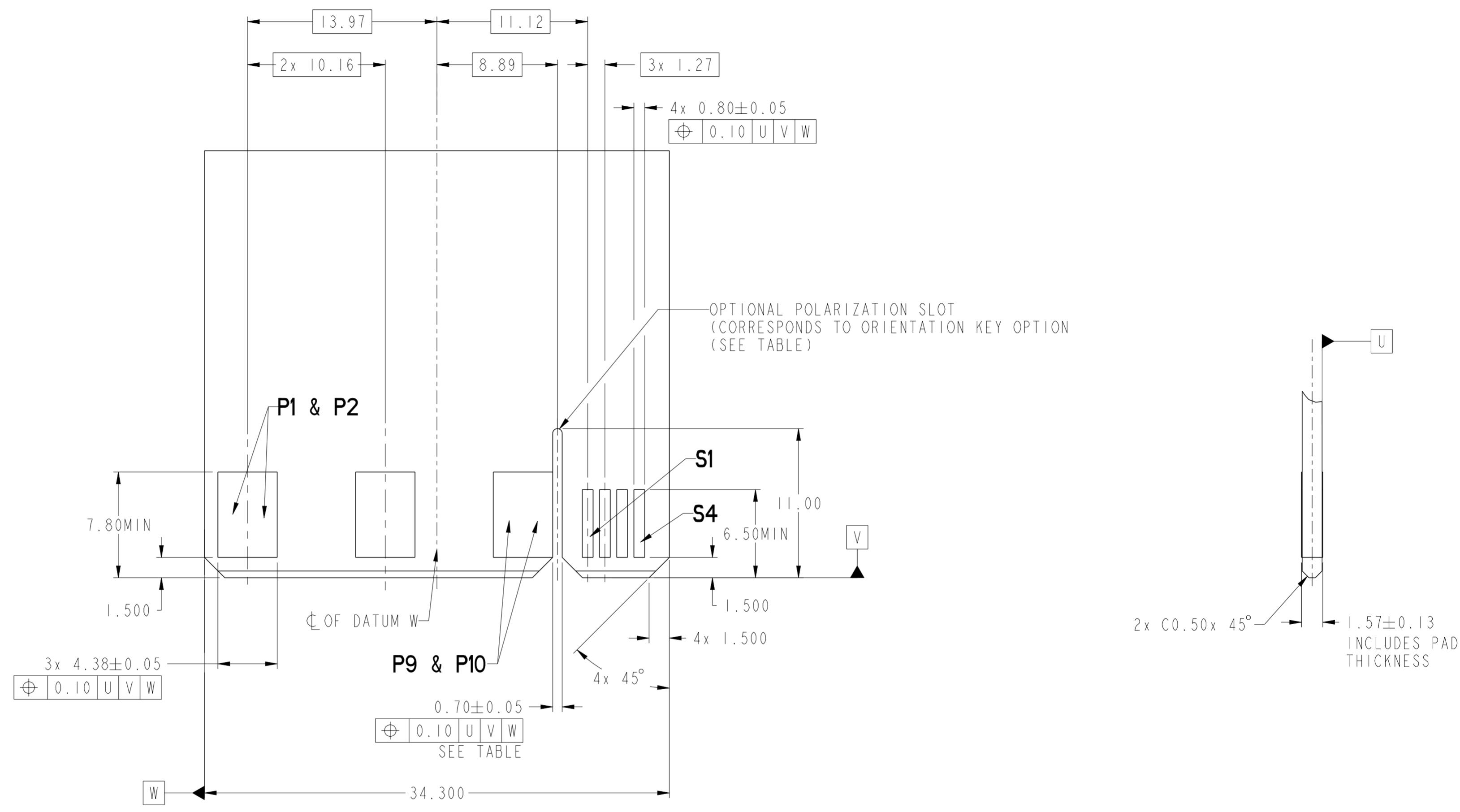

**RECOMMENDED MATING BOARD FOOTPRINT**

spec ref	-	dr	De-Ming Lu	2013/10/10	projection	MM	size	A2	scale	1:1	
tolerance std	ASME Y14.5	eng	Sunny2 Liu	2016/05/10			ecn no	ELX-DG-24036-1			
TOLERANCES UNLESS OTHERWISE SPECIFIED		chr	Terris Liu	2016/05/20			rel level	Released			
surface	ASME Y14.5	appr	Pai-Ming Zheng	2016/05/24			product family	-			
linear	0.X ±0.5 0.XX ±0.25 0.XXX ±0.10	Amphenol FCI	SMT REC (20P+8S) OMIT 8P		cat. no.	-		Product - Customer Drw	sheet 3 of 4	rev	C
angular	0° ±2°	HPCE - (STRADDLE MOUNT)		-		-		-			

Amphenol FCI

© 2016 APCI

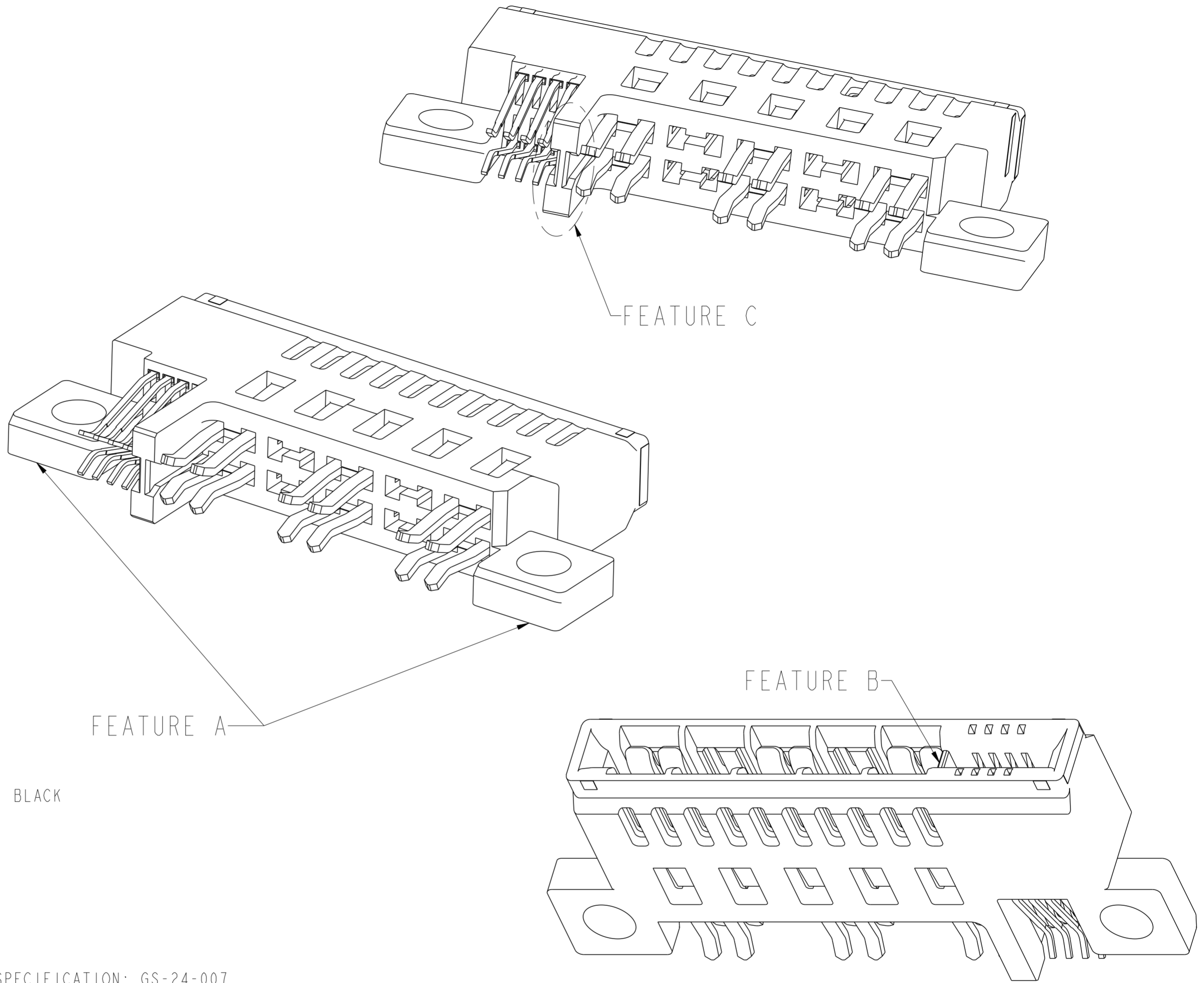

NOTES:

1. CONNECTOR MATERIALS:  
 HOUSING: HIGH TEMPERATURE THERMAL PLASTIC, BLACK  
 UL 94V-0 COMPLIANT  
 CONTACTS: HIGH PERFORMANCE COPPER ALLOY.
2. CONTACT FINISH REF. GS-12-604 SECTION 5.2.
3. PRODUCT SPECIFICATION: GS-12-604.
4. APPLICATION SPECIFICATION: GS-20-128.
5. PRODUCT MARKING ON HOUSING IN AREA SHOWN MEETS AFCI SPECIFICATION: GS-24-007.
6. PACKAGING MEETS FCI SPECIFICATION GS-14-937.
7. HOUSING COMPONENT WILL WITHSTAND EXPOSURE TO 260°C PEAK TEMPERATURE FOR 60 SECONDS IN A CONVECTION, INFRA-RED, OR VAPOR PHASE REFLOW OVEN.
8. HOST BOARD ALIGNMENT KEY IS RECOMMENDED TO ENSURE PROPER ALIGNMENT OF SOLDER TAILS WITH HOST BOARD PADS.
9. A  $\triangle$  C SYMBOL WILL BE NEXT TO ANY DIMENSION, VIEW, OR NOTE WHICH HAS BEEN MODIFIED WITH THE CURRENT DRAWING REVISION.

Amphenol  
FCi

© 2016 AFCI

spec ref	-	dr	De-Ming Lu	2013/10/10	projection	MM	size	A2	scale	4:1
tolerance std	ASME Y14.5	eng	Sunny2 Liu	2016/05/10			ecn no	ELX-DG-24036-1		
TOLERANCES UNLESS OTHERWISE SPECIFIED		chr	Terris Liu	2016/05/20			rel level	Released		
surface	linear	appr	Pei-Ming Zheng	2016/05/24	product family	CARD EDGE	rel level	Released		
ASME Y14.5	angular			title SMT REC (20P+8S) OMIT 8P HPCE - (STRADDLE MOUNT)	cat. no. -	Product - Customer Drw	dng no 10127593	rev C	sheet 4 of 4	