

LENGTH TABLE				
MATERIAL NO. (STANDARD)	MATERIAL NO. (-56 OPT.)	NO. OF CIRCUITS	"B"	"A"
399200302	399200602	02	15.0 (1.591)	32 (1.25)
399200303	399200603	03	30.0 (1.181)	47 (1.84)
399200304	399200604	04	45.0 (1.772)	62 (2.43)
399200305	399200605	05	60.0 (2.362)	77 (3.02)
399200306	399200606	06	75.0 (2.952)	92 (3.61)
399200307	399200607	07	90.0 (3.543)	107 (4.20)
399200308	399200608	08	105.0 (4.134)	122 (4.79)
399200309	399200609	09	120.0 (4.724)	137 (5.38)
399200310	399200610	10	135.0 (5.315)	152 (5.97)
399200311	399200611	11	150.0 (5.906)	167 (6.57)
399200312	399200612	12	165.0 (6.496)	182 (7.16)

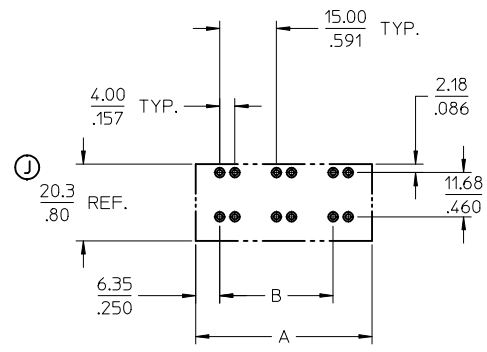
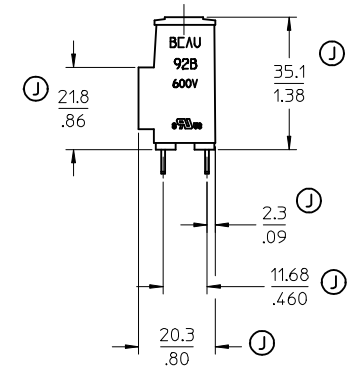
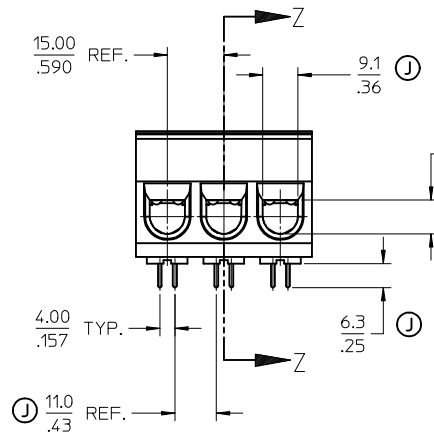
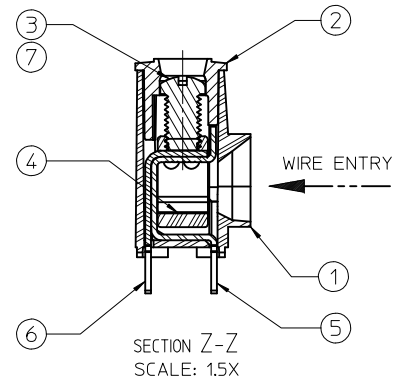
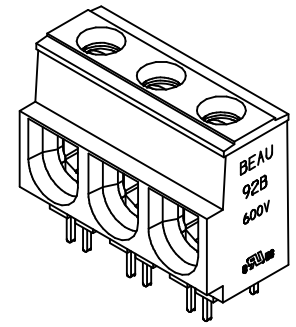
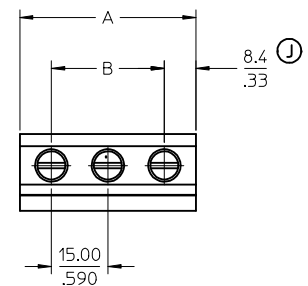

RECOMMENDED PTH PATTERN
 Ø152 (.060) MINIMUM FINISHED HOLE
 SCALE 1:1

- NOTES:
1. MATERIAL: SEE TABLE.
 2. FINISHES: SEE TABLE.
 3. PRODUCT SPECIFICATION: NOT REQUIRED.
 4. PACKAGING: NOT REQUIRED.
 5. MATES WITH: NONE.
 6. ALL FEATURES ARE TYPICAL UNLESS OTHERWISE NOTED.
 7. "XX" REFERS TO THE NUMBER OF CIRCUIT POSITIONS
 8. DESIGNED TO MEET NEC & UL 1059 CLASS C 600 VOLTS
 9. MULTIPLE TAIL DESIGN FOR LOWER PCB CURRENT DENSITIES
 10. PROVEN PRESSURE CLAMP STYLE CONNECTION
 11. AVAILABLE IN VARIOUS LENGTHS
 12. WINDOW ACCEPTS 133/23 STRANDED #2 AWG, #3 AWG AND 19 STRAND #1 AWG

7	*XX*	SCREW, 1/4-28, SLOTTED, ST. STEEL	STAINLESS STEEL	TIN
6	*XX*	OUTER TERMINAL	COPPER	TIN
5	*XX*	INNER TERMINAL	COPPER	TIN
4	*XX*	CAGE	BRASS	NICKEL
3	*XX*	SCREW, 1/4-28, SLOTTED, BRONZE	BRONZE	TIN
2	1	COVER	THERMOPLASTIC	BLACK
1	1	BODY	THERMOPLASTIC	BLACK
ITEM	QTY.	DESCRIPTION	MATERIAL	FINISH

REDRAWN: 35 WAS 351 CORRECTED M/M IN DEC. PL. EC NO: 1PG2015-0628 2014/10/03 DRWINRSTONE 2014/10/27 CHYKDB ARDEN 2014/10/23 APPR: JFMURPHY	QUALITY SYMBOLS ▽=0 ▽=0	GENERAL TOLERANCES (UNLESS SPECIFIED)		DIMENSION STYLE MM/IN		SCALE 1:1	DESIGN UNITS INCH	THIRD ANGLE PROJECTION		
		4 PLACES ± --- ± ---	INCH	DRAWN BY RSTONE	DATE 2014/10/03	TITLE SR BTS #1-#8AWG 600V				
		3 PLACES ± --- ± .005	mm	CHECKED BY B ARDEN	DATE 2014/10/27	DOCUMENT NO. SD-39920-006				
		2 PLACES ± 0.13 ± .01 1 PLACE ± 0.3 ± --- 0 PLACE ± --- ± ---	INCH	APPROVED BY JFMURPHY	DATE 2014/10/23	SHEET NO. 1 OF 1				
ANGULAR ± 2 °		DRAFT WHERE APPLICABLE MUST REMAIN WITHIN DIMENSIONS		MATERIAL NO. SEE CHART	THIS DRAWING CONTAINS INFORMATION THAT IS PROPRIETARY TO MOLEX INCORPORATED AND SHOULD NOT BE USED WITHOUT WRITTEN PERMISSION					