

ALL DIMENSIONS ARE REFERENCE
(SEE C-281-XXXX-X FOR CONTROLLING PRINT)

CC81X-XXXX-01-X

SUPPLIED
-L: LOOSE
-R: REEL

LEAD STYLE
-2426: 24-26 AWG
-2830: 28-30 AWG

PLATING SPECIFICATION
-L: 10μ" SELECTIVE GOLD IN CONTACT AREA, MATTE TIN ON TAIL.
-S: 30μ" SELECTIVE GOLD IN CONTACT AREA, MATTE TIN ON TAIL.

DO NOT SCALE FROM THIS PRINT

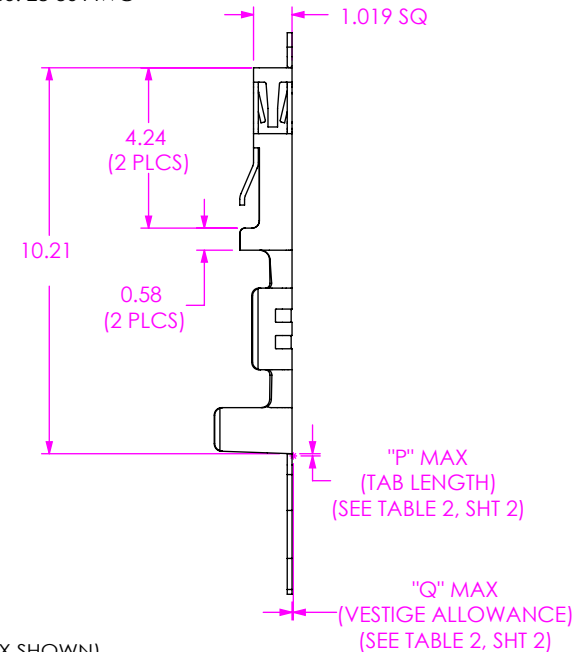
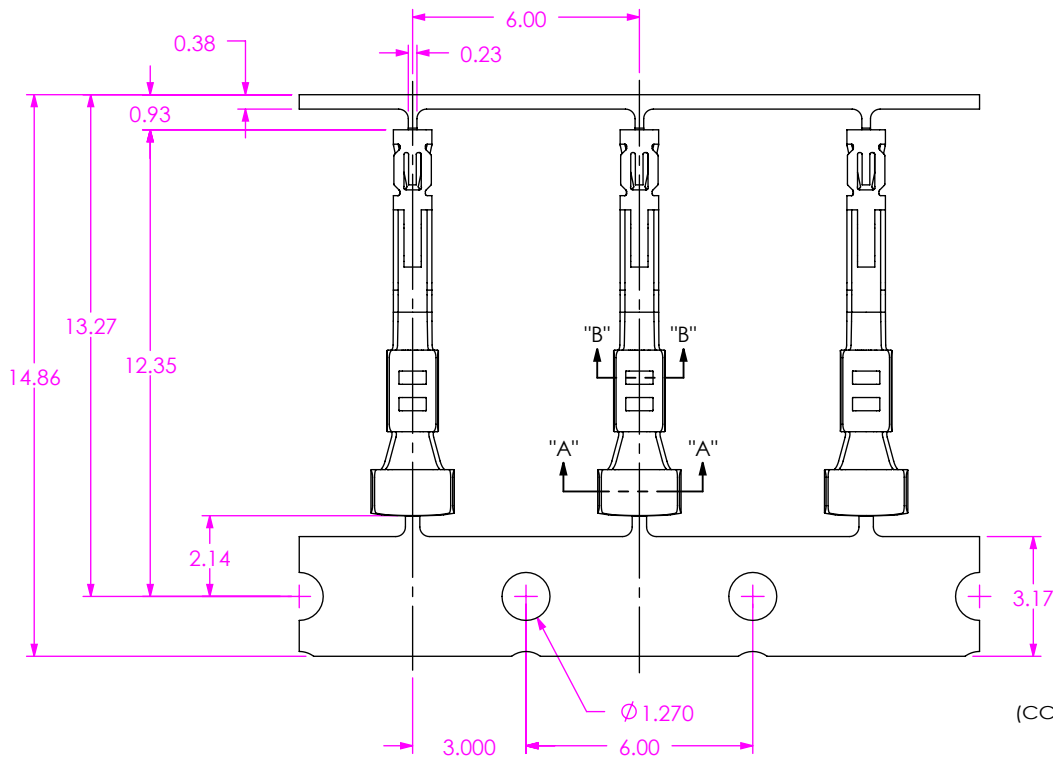
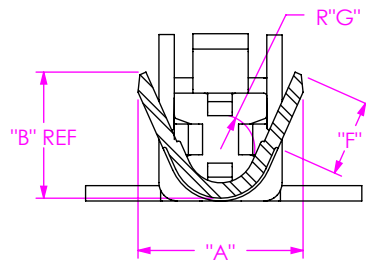
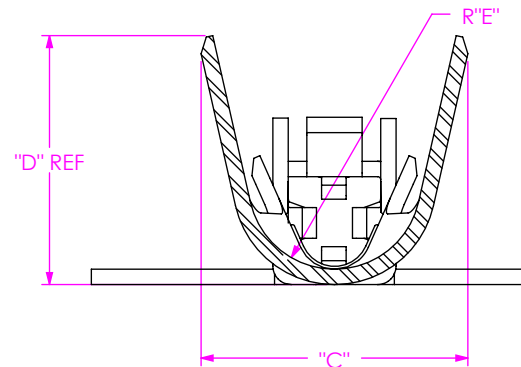

FIG. 1
(CC81X-XXXX-01-X SHOWN)

LEAD STYLE	"A"	"B"	"C"	"D"	"E"	"F"	"G"
-2426	1.36	1.04	2.21	2.06	0.71	0.63	0.28
-2830	1.03	0.87	1.37	1.45	0.36	0.35	0.18



SECTION "B"- "B"
SCALE 16 : 1



SECTION "A"- "A"
SCALE 16 : 1



NOTES:

1. PLATED C-281 PARTS TO BE PULLED, PLATING OPTION CONFIRMED, POSITIONED AS SHOWN ON SAMTEC REEL WITH VIEWPORTS, LABELED CC81R WITH APPROPRIATE PLATING CALLOUT AND LABEL PLACED AS SHOWN.
2. MAXIMUM NO OF SPLICES PER REEL: 2.
3. SPLICES ARE NOT TO BE CONNECTED.
4. NUMBER OF SPLICES TO BE MARKED ON EACH REEL.
5. REELED PARTS TO BE INTERLEAVED WITH PAPER BETWEEN EACH LAYER OF PARTS.
6. ALLOWABLE INTERLEAF SPLICES PER REEL: 3.
7. SECURELY CONNECT INTERLEAF SPLICE.
8. OUTER WRAP SHALL RECEIVE PROTECTIVE REEL BAND PER BELOW: RB-24-0.75-P.
9. DUE TO PLATING REQUIREMENTS CONTACT SAMPLES MAY BE REMOVED INTERMITTINGLY FROM THE CARRIER RESULTING IN SMALL GAPS BUT DOES NOT AFFECT FINAL COUNT.
10. QTY PER REEL: 17,000 +/-15 PCS.

UNLESS OTHERWISE SPECIFIED,
DIMENSIONS ARE IN MILLIMETERS.

TOLERANCES ARE:

DECIMALS ANGLES

PROPRIETARY NOTE

THIS DOCUMENT CONTAINS CONFIDENTIAL AND PROPRIETARY INFORMATION AND ALL DESIGN, MANUFACTURING, REPRODUCTION, USE, PATENT RIGHTS AND SALES RIGHTS ARE EXPRESSLY RESERVED BY SAMTEC, INC. THIS DOCUMENT SHALL NOT BE DISCLOSED, IN WHOLE OR PART, TO ANY UNAUTHORIZED PERSON OR ENTITY NOR REPRODUCED, TRANSFERRED OR INCORPORATED IN ANY OTHER PROJECT IN ANY MANNER WITHOUT THE EXPRESS WRITTEN CONSENT OF SAMTEC, INC.



520 PARK EAST BLVD, NEW ALBANY, IN 47150
PHONE: 812-944-6733 FAX: 812-948-5047
e-Mail info@SAMTEC.com code 55322

MATERIAL: DO NOT SCALE DRAWING SHEET SCALE: 8:1

BeCu
THICKNESS: 0.127+/-0.008

DESCRIPTION: 2mm C.L. DISCRETE WIRE CONTACT

DWG. NO. CC81X-XXXX-01-X

BY: J. BORGELT 3/16/09 SHEET 1 OF 2

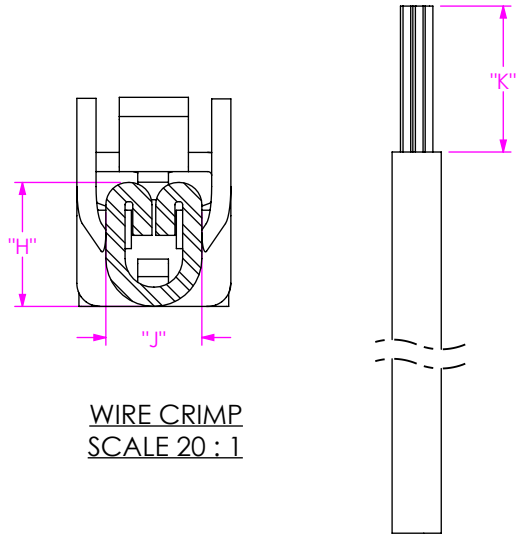

WIRE CRIMP
SCALE 20 : 1

INSULATOR STRIP LENGTH

P/N	AWG	STRANDS / AWG	INSULATION OD	"H"	"J"	"K"	"P" MAX (TAB LENGTH)	"Q" MAX (VESTIGE LENGTH)	PULL FORCE (LBS)
CC81X-2830-01-X	30	7/38	0.7366 - 0.889	.432	.838	3.180	.0075	.0010	1.5
	30TC	7/38	0.7366 - 0.889	.432	.838	3.180	.0075	.0010	1.5
	28	7/36	0.8128 - 0.9652	.457	.838	3.180	.0075	.0010	2
	28TC	7/36	0.8128 - 0.9652	.457	.838	3.180	.0075	.0010	2
CC81X-2426-01-X	26	7/34	1.2192 - 1.3716	.584	.889	3.180	.0075	.0010	3
	24TC	7/32	1.0414 - 1.1938	.711	.889	3.180	.0075	.0010	5
	24	7/32	1.3462-1.4986	.711	.889	3.180	.0075	.0010	5

FIG 2
RECOMMENDED PROCESSING

UNWINDING DIRECTION

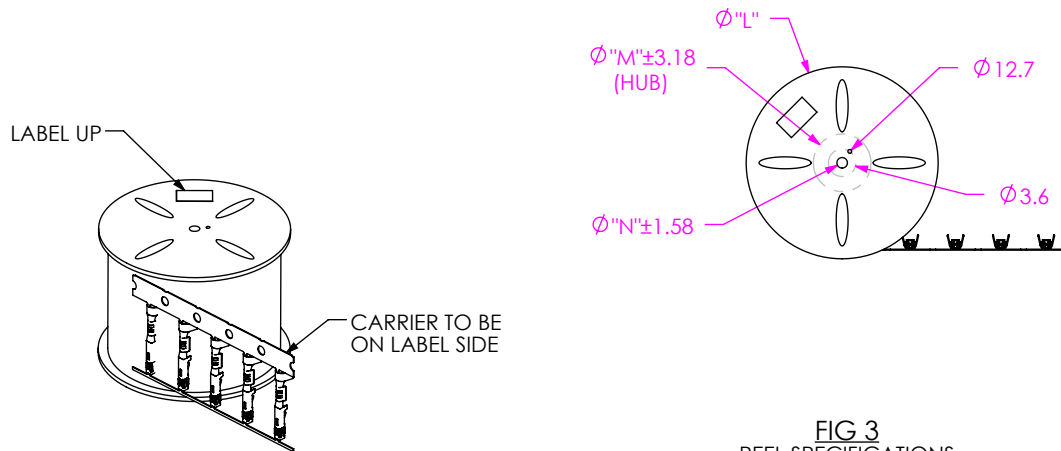

FIG 3
REEL SPECIFICATIONS

SUPPLIED	REEL PART NUMBER	"L"	"M"	"N"
-R	R-24-05.00-0.75-P	609.6	203.20	28.58

PROPRIETARY NOTE
THIS DOCUMENT CONTAINS CONFIDENTIAL AND PROPRIETARY INFORMATION AND ALL DESIGN, MANUFACTURING, REPRODUCTION, USE, PATENT RIGHTS AND SALES RIGHTS ARE EXPRESSLY RESERVED BY SAMTEC, INC. THIS DOCUMENT SHALL NOT BE DISCLOSED, IN WHOLE OR PART, TO ANY UNAUTHORIZED PERSON OR ENTITY NOR REPRODUCED, TRANSFERRED OR INCORPORATED IN ANY OTHER PROJECT IN ANY MANNER WITHOUT THE EXPRESS WRITTEN CONSENT OF SAMTEC, INC.

DO NOT SCALE DRAWING

SHEET SCALE: 8:1



520 PARK EAST BLVD, NEW ALBANY, IN 47150
PHONE: 812-944-6733 FAX: 812-948-5047
e-Mail info@SAMTEC.com code 55322

DESCRIPTION: 2mm C.L. DISCRETE WIRE CONTACT

DWG. NO. CC81X-XXXX-01-X

BY: J. BORGELT 3/16/09 SHEET 2 OF 2