

0.3A/0.6A, High/Low-Side MOSFET Driver

General Description

The RT7028A/B is a high-voltage gate driver IC with dual outputs. The IC, together with an external bootstrap network, drives dual n-channel MOSFETs or IGBTs with input voltage rail up to 600V.

The IC is equipped with a “common-mode dV/dt noise canceling technique” to provide high dV/dt immunity which enables stable operation under high dV/dt noise circumstances. Two Under-Voltage Lockout (UVLO) functions continuously monitor the bias voltages on VCC and BOOT-to-LX for preventing malfunction when the bias voltages are lower than the specified threshold voltages. The logic level of the PWM signal input pins are compatible with standard TTL logic level for ease of interfacing with controlling devices.

Applications

- PDP Scan Driver
- Fluorescent Lamp Ballast
- SMPS
- Motor Driver

Features

- Floating Channels Designed for Bootstrap Operation with Input Voltage up to 600V
- 300mA/600mA Sourcing/Sinking Current
- High dV/dt Immunity : $\pm 50V/ns$
- VCC and VBOOT – LX Supply Range from 10V to 20V
- Under-Voltage Lockout Functions for Both Channels
- TTL Compatible Logic Input
- Matched Propagation Delay below 50ns
- Outputs in Phase with Input (RT7028A) or Out of Phase with Input (RT7028B)

Ordering Information

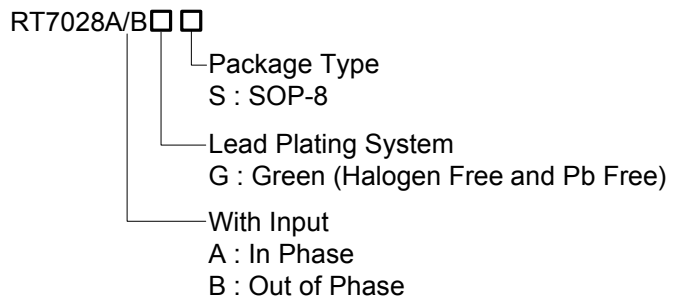

Note :

Richtek products are :

- ▶ RoHS compliant and compatible with the current requirements of IPC/JEDEC J-STD-020.
- ▶ Suitable for use in SnPb or Pb-free soldering processes.

Pin Configuration

(TOP VIEW)

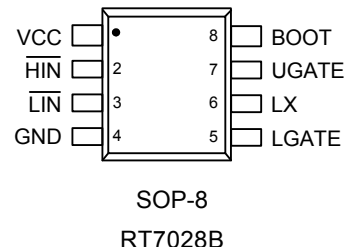
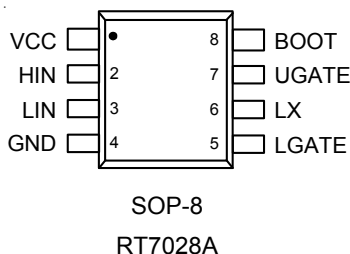

Marking Information

RT7028AGS

RT7028AGS : Product Number
YMDNN : Date Code

RT7028A
GSYMDNN
●

RT7028BGS

RT7028BGS : Product Number
YMDNN : Date Code

RT7028B
GSYMDNN
●

Typical Application Circuit

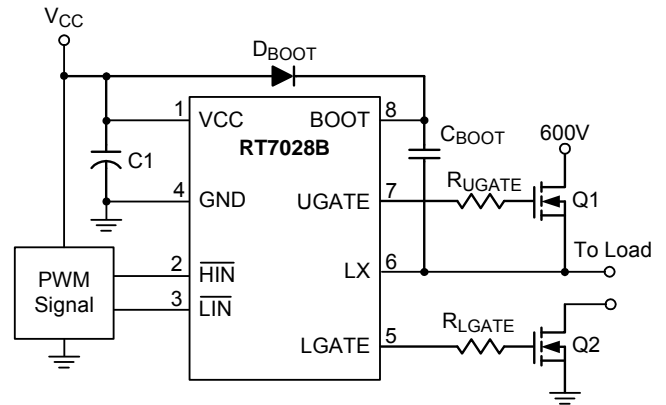
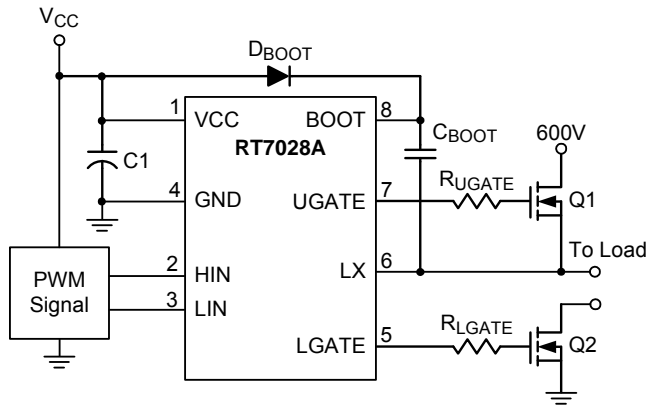

Functional Pin Description

Pin No.	Pin Name	Pin Function
1	VCC	Supply voltage input.
2	HIN (RT7028A)	Logic input for high-side gate driver.
	$\overline{\text{HIN}}$ (RT7028B)	Logic input for high-side gate driver.
3	LIN (RT7028A)	Logic input for low-side gate driver.
	$\overline{\text{LIN}}$ (RT7028B)	Logic input for low-side gate driver.
4	GND	Logic ground and low-side driver return.
5	LGATE	Low-side driver output.
6	LX	Return for high-side gate driver.
7	UGATE	High-side driver output.
8	BOOT	Bootstrap supply for high-side gate driver.

Functional Block Diagram

For RT7028A

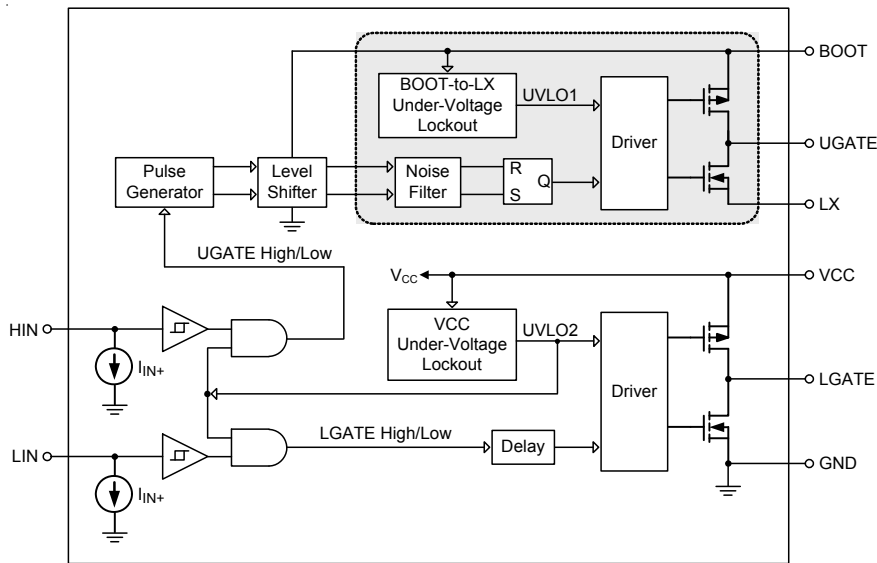

For RT7028B

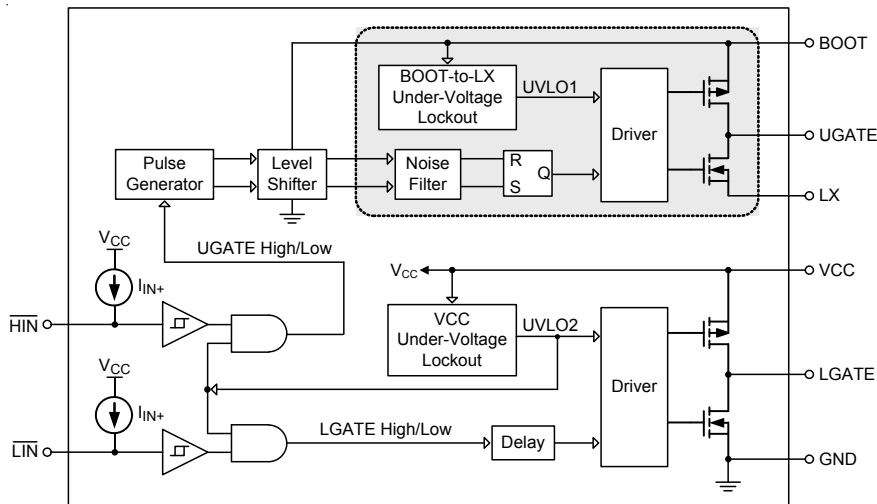

Operation

The RT7028A/B is a high-voltage gate driver for driving high-side and low-side MOSFETs. The RT7028A/B uses ultra high voltage device and floating well to allowed UGATE to drive external MOSFET operating up to 600V. When the HIN voltage is above the logic-high threshold, the UGATE voltage goes high to turn on the external MOSFET. When the HIN voltage is below the logic-low threshold, the MOSFET is turned off. The operating behavior of the LGATE, controlled by the LIN pin, is like the behavior of the UGATE.

Under-Voltage Lockout (UVLO) Function

When the VCC or BOOT-to-LX voltage is lower the UVLO threshold, the UGATE and LGATE output will be disabled.

Pulse Generator

The pulse generator is used to transmit the HIN input signal to the UGATE driver.

Absolute Maximum Ratings (Note 1)

- VCC Supply Voltage, V_{CC} ----- -0.3V to 25V
- LX to GND ----- -0.3V to 625V
- BOOT to LX, $V_{BOOT-LX}$ ----- -0.3V to 25V
- UGATE to LX ----- -0.3V to $V_{BOOT-LX} + 0.3V$
- LGATE to GND ----- -0.3V to $V_{CC} + 0.3V$
- HIN, LIN, \overline{HIN} , \overline{LIN} to GND ----- -0.3V to $V_{CC} + 0.3V$
- Allowable LX Voltage Slew Rate, dV_{LX}/dt ----- -50V/ns to 50V/ns
- Power Dissipation, P_D @ $T_A = 25^\circ C$
 - SOP-8 ----- 0.53W
- Package Thermal Resistance (Note 2)
 - SOP-8, θ_{JA} ----- 188°C/W
- Junction Temperature ----- 150°C
- Lead Temperature (Soldering, 10 sec.) ----- 260°C
- Storage Temperature Range ----- -65°C to 150°C
- ESD Susceptibility (Note 3)
 - HBM (Human Body Model)
 - Except HV pin ----- 2kV
 - HV (BOOT, UGATE and LX) to GND ----- 1kV

Recommended Operating Conditions (Note 4)

- VCC Supply Voltage, V_{CC} ----- 10V to 20V
- LX to GND ----- 0V to 600V
- BOOT-to-LX, $V_{BOOT-LX}$ ----- 10V to 20V
- UGATE to LX ----- 0V to $V_{BOOT-LX}$
- LGATE to GND ----- 0 to V_{CC}
- HIN, LIN, \overline{HIN} , \overline{LIN} to GND ----- 0 to V_{CC}
- Ambient Temperature Range ----- -40°C to 125°C

Electrical Characteristics

($V_{CC} = V_{BOOT-LX} = 15V$, $T_A = 25^\circ C$, unless otherwise specified)

Parameter	Symbol	Test Conditions	Min	Typ	Max	Unit
VCC Under-Voltage Lockout Threshold (On)	V_{THON_VCC}		7	8.5	10	V
VBOOT - LX Under-Voltage Lockout Threshold (On)	V_{THON_BOOT}		7	8.5	10	V
VCC Under-Voltage Lockout Threshold (Off)	V_{THOFF_VCC}		6.3	7.8	9.3	V
VBOOT - LX Under-Voltage Lockout Threshold (Off)	V_{THOFF_BOOT}		6.3	7.8	9.3	V
VCC Under-Voltage Lockout Hysteresis	V_{HYS_VCC}		--	0.7	--	V
VBOOT - LX Under-Voltage Lockout Hysteresis	V_{HSY_BOOT}		--	0.7	--	V

Parameter	Symbol	Test Conditions	Min	Typ	Max	Unit
LX Leakage Current	I _{LK}	V _{BOOT} = V _{LX} = 600V	--	--	50	μA
VCC Quiescent Current	I _{Q_VCC}		--	220	400	μA
BOOT-to-LX Quiescent Current	I _{Q_BOOT-LX}		--	100	200	μA
VCC Operating Current	I _{P_VCC}	f = 20kHz,	--	--	600	μA
BOOT-to-LX Operating Current	I _{P_BOOT-LX}	UGATE = LGATE = Open	--	--	600	μA
HIN, LIN, $\overline{\text{HIN}}$, LIN Input Voltage	Logic-High	V _{IH}	2.5	--	--	V
	Logic-Low	V _{IL}	--	--	0.8	
UGATE, LGATE Output Voltage	High-Level	V _{OH} Sourcing current = 2mA, V _{BOOT} - V _{LGATE} , V _{CC} - V _{LGATE}	--	50	200	mV
	Low-Level	V _{OL} Sinking current = 2mA, V _{UGATE-LX} , V _{LGATE}	--	20	100	
HIN, LIN Input Current	Logic-High	I _{IN+} HIN = LIN = V _{CC} (RT7028A)	--	2	10	μA
	Logic-Low	I _{IN-} HIN = LIN = 0V (RT7028A)	-1	--	--	
$\overline{\text{HIN}}$, $\overline{\text{LIN}}$ Input Current	Logic-High	I _{IN-} $\overline{\text{HIN}}$ = $\overline{\text{LIN}}$ = V _{CC} (RT7028B)	-1	--	--	μA
	Logic-Low	I _{IN+} $\overline{\text{HIN}}$ = $\overline{\text{LIN}}$ = 0V (RT7028B)	--	2	10	
UGATE and LGATE Sourcing Current	I _{O+}	UGATE = LX, LGATE = GND, current pulse width < 10μs, low duty	--	290	--	mA
UGATE and LGATE Sinking Current	I _{O-}	UGATE = BOOT, LGATE = V _{CC} , current pulse width < 10μs, low duty	--	600	--	mA

Dynamic Electrical Characteristics (Note 5)

(V_{CC} = V_{BOOT-LX} = 15V, LX = GND, C_L = 1000pF, T_A = 25°C, unless otherwise specified)

Parameter	Symbol	Test Conditions	Min	Typ	Max	Unit
Turn-On Delay	t _{ON}		--	150	220	ns
Turn-Off Delay	t _{OFF}	V _{LX} = 0 or 600V (Note 6)	--	150	220	ns
Turn-On Rising Time	t _R		--	70	170	ns
Turn-Off Falling Time	t _F		--	35	90	ns
Delay Matching Time, UGATE and LGATE Turn-On/Off	t _M		--	--	50	ns

Note 1. Stresses beyond those listed “Absolute Maximum Ratings” may cause permanent damage to the device. These are stress ratings only, and functional operation of the device at these or any other conditions beyond those indicated in the operational sections of the specifications is not implied. Exposure to absolute maximum rating conditions may affect device reliability.

Note 2. θ_{JA} is measured under natural convection (still air) at T_A = 25°C with the component mounted on a high effective-thermal-conductivity four-layer test board on a JEDEC 51-7 thermal measurement standard.

Note 3. Devices are ESD sensitive. Handling precaution is recommended.

Note 4. The device is not guaranteed to function outside its operating conditions.

Note 5. Please refer to the Timing Diagram and Dynamic Waveforms in the Application Information.

Note 6. Turn-off Delay for V_{LX} = 600V is guaranteed by design.

Typical Operating Characteristics

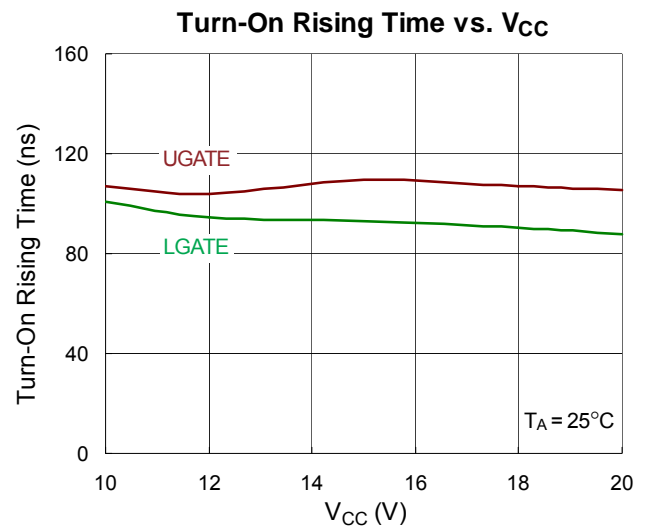
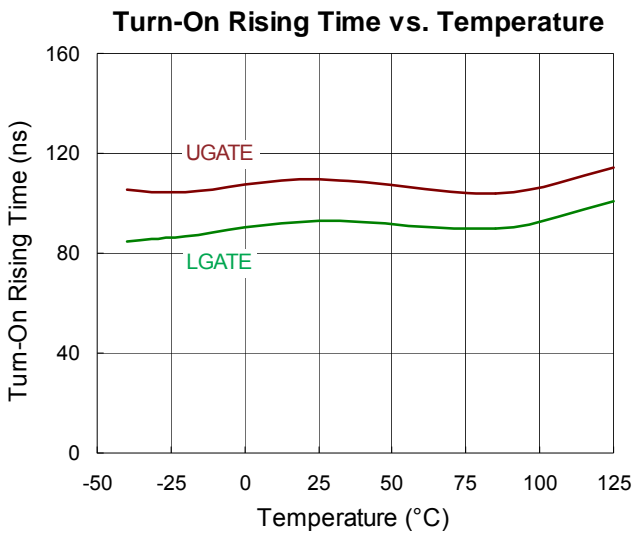
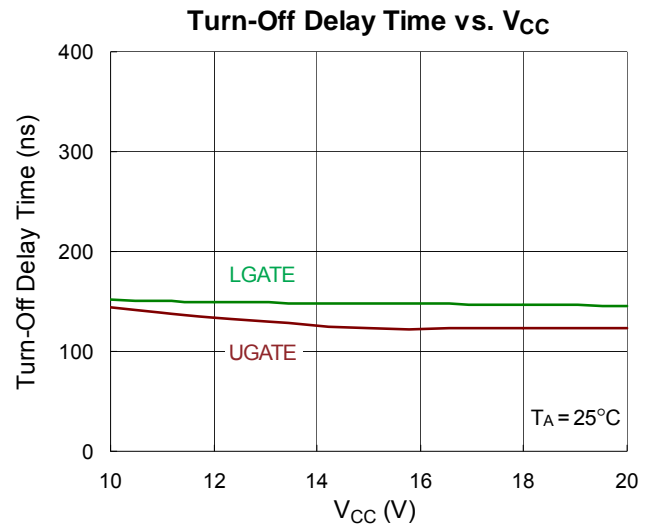
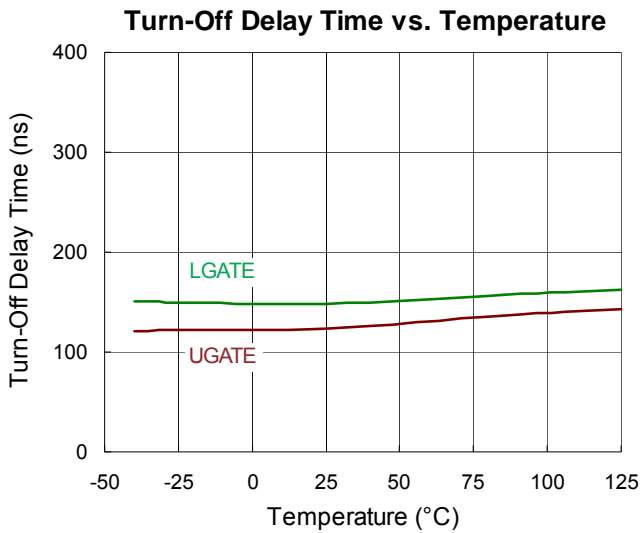
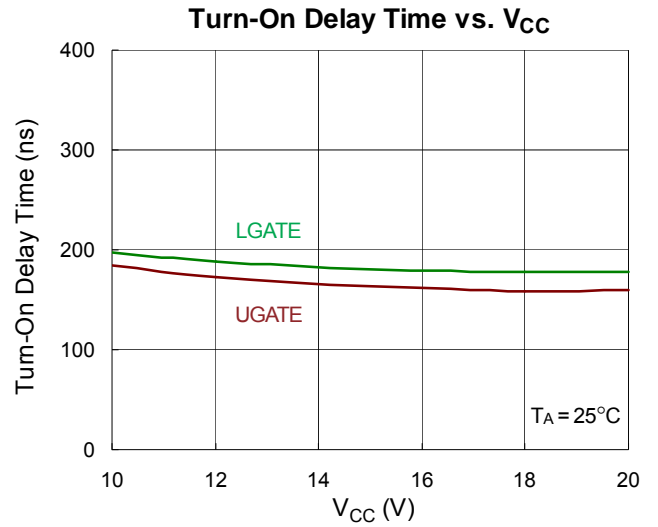
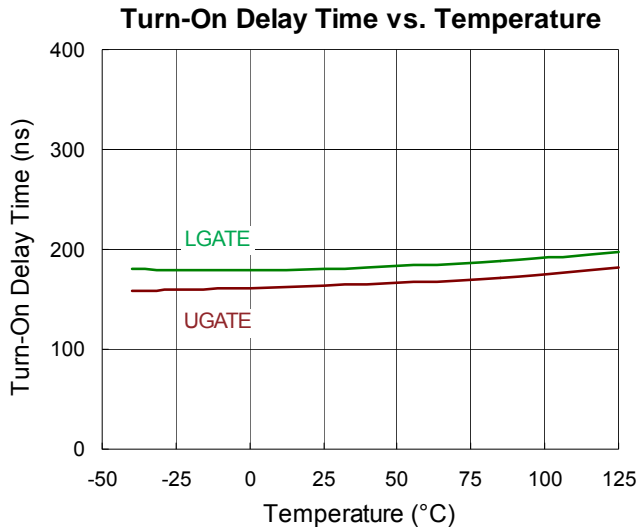

Turn-Off Falling Time vs. Temperature

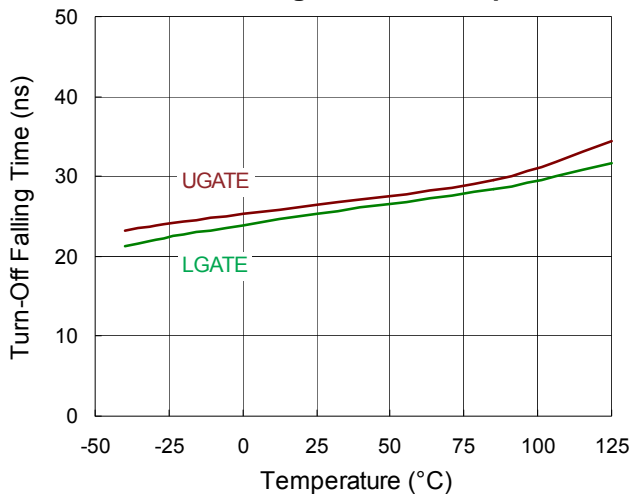

Turn-Off Falling Time vs. V_{CC}

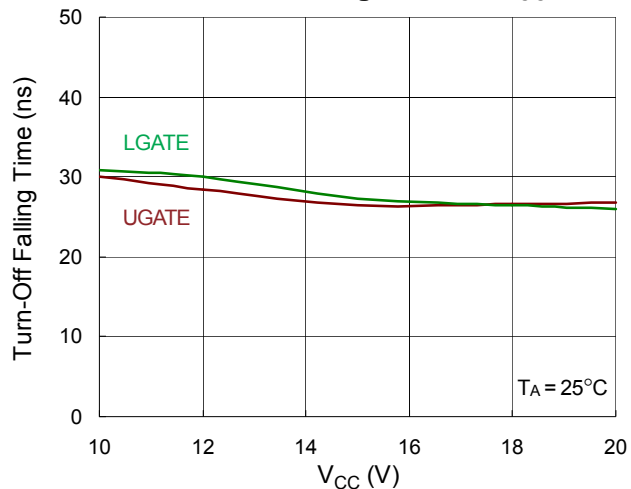

V_{CC} Operating Current vs. Temperature

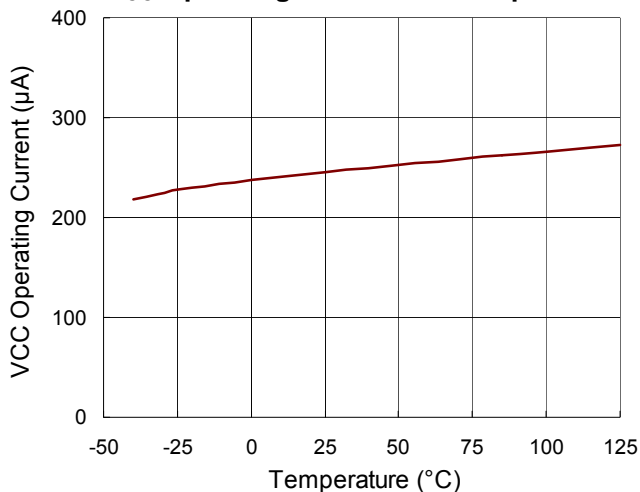

V_{CC} Operating Current vs. V_{CC}

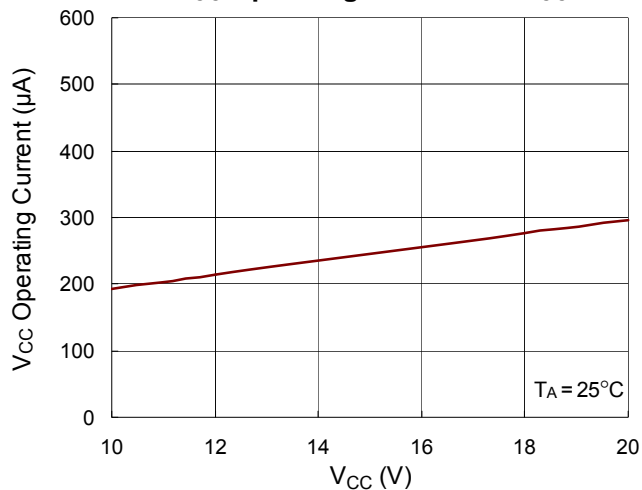

V_{BOOT-LX} Operating Current vs. Temperature

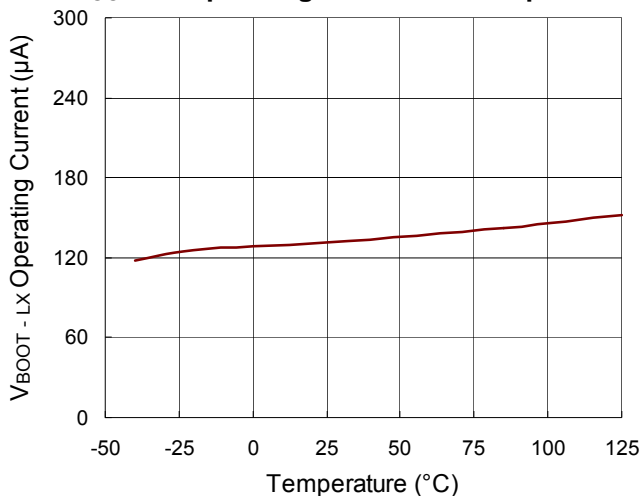

V_{BOOT-LX} Operating Current vs. V_{BOOT-LX}

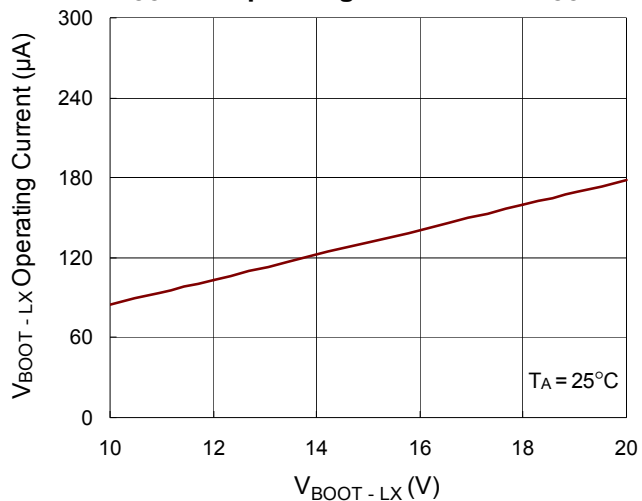

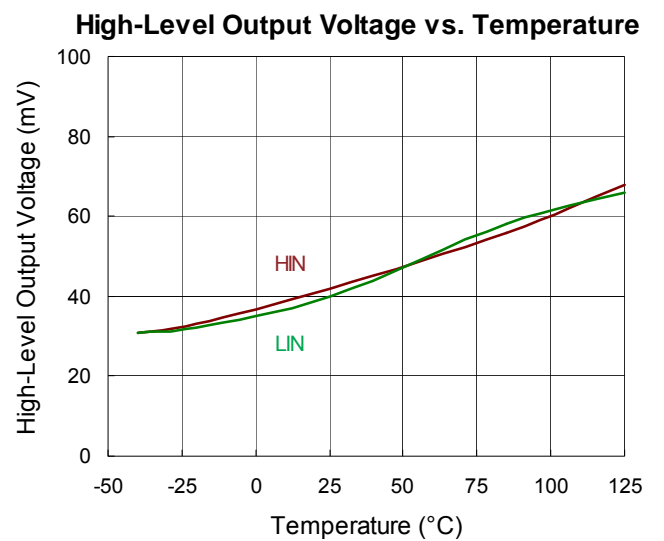
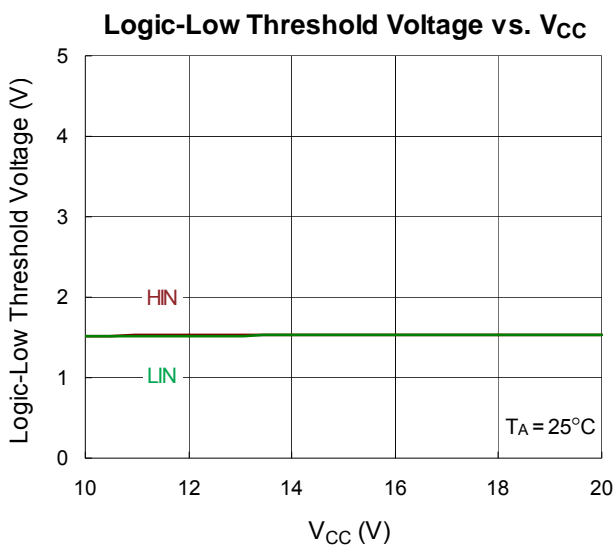
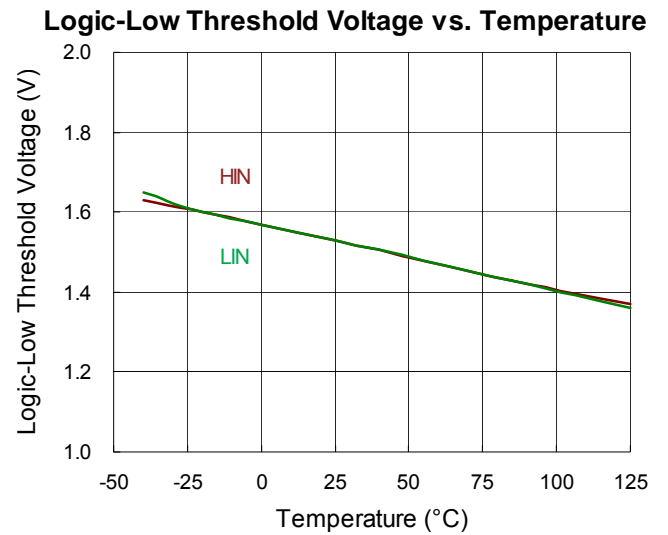
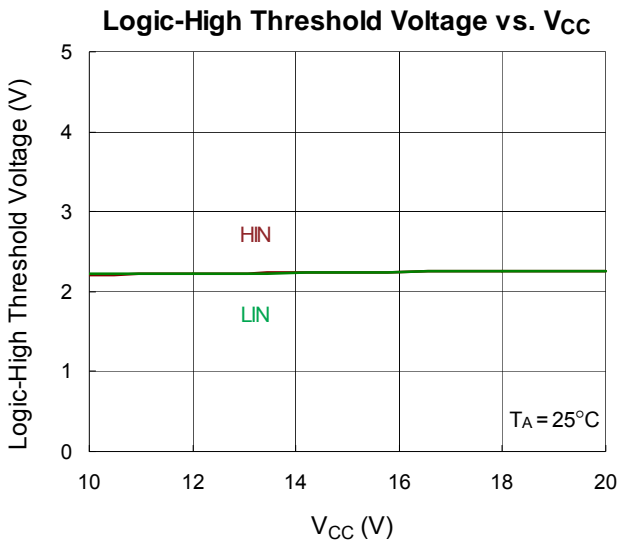
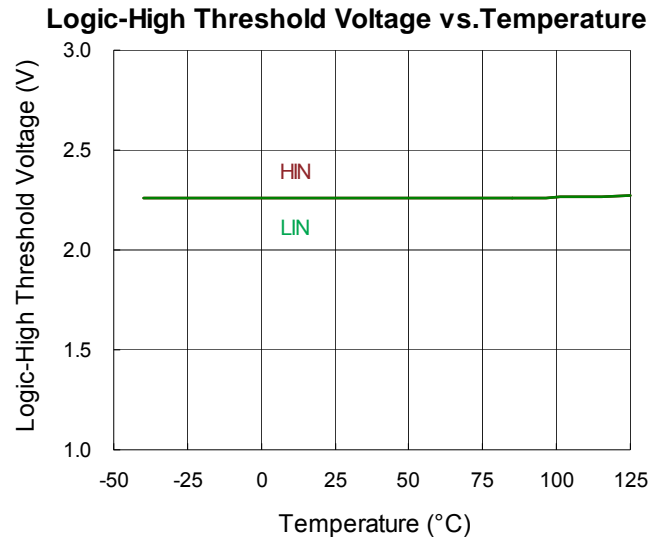
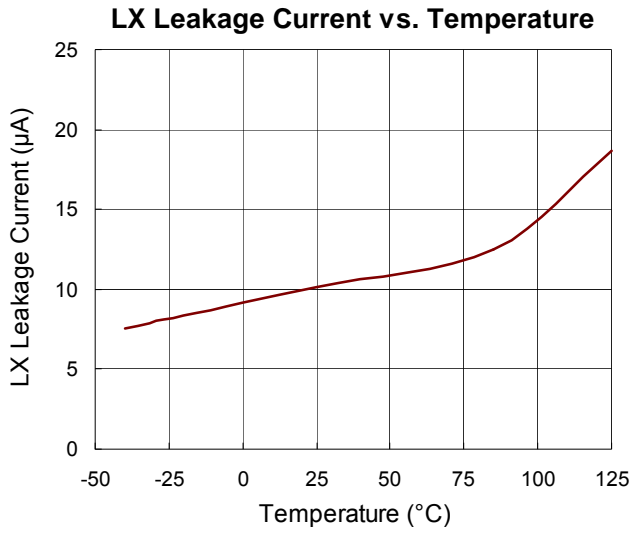

High-Level Output Voltage vs. V_{CC} or $V_{BOOT-LX}$

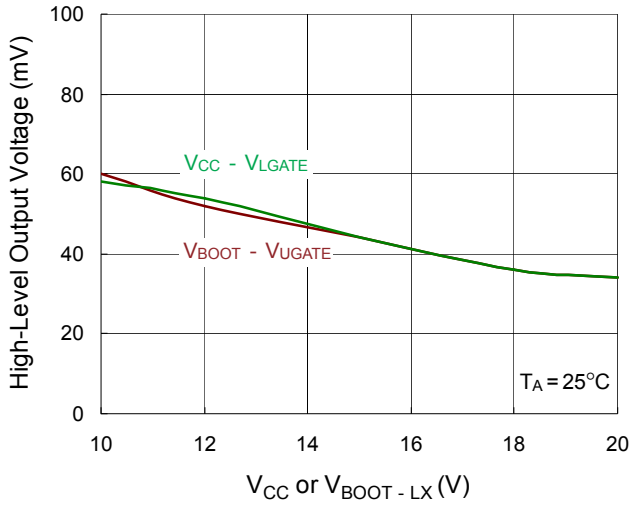

Low-Level Output Voltage vs. Temperature

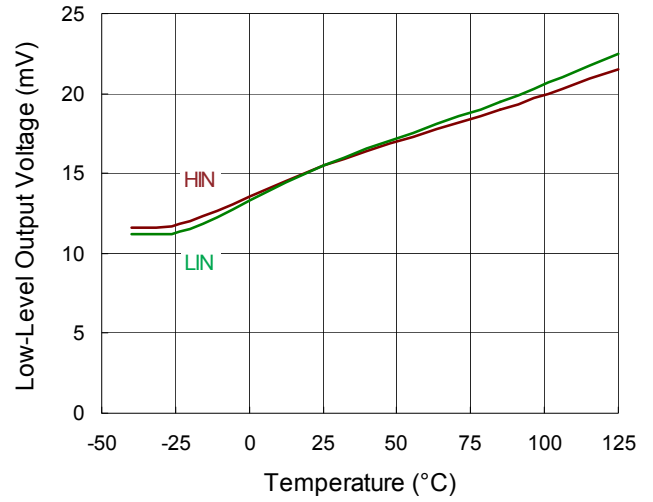

Low-Level Output Voltage vs. V_{CC} or $V_{BOOT-LX}$

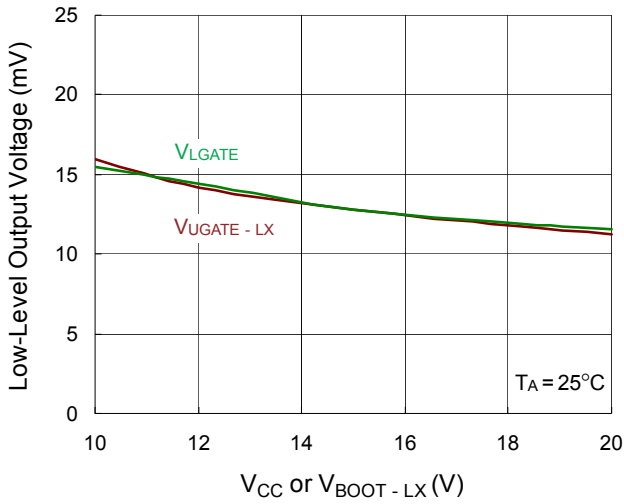

$V_{BOOT-LX}$ Quiescent Current vs. Temperature

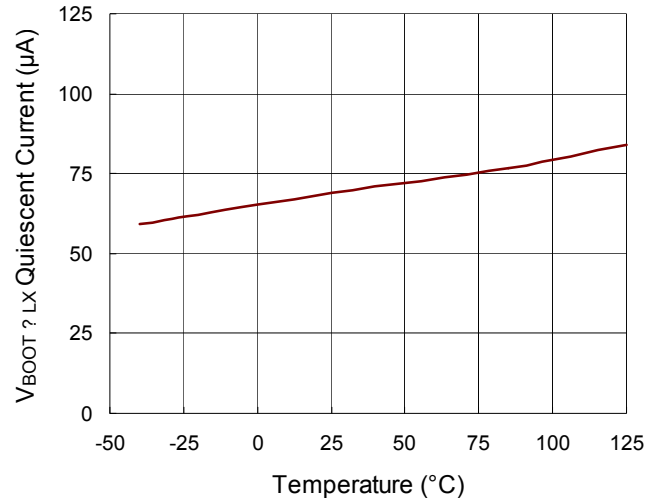

V_{CC} Quiescent Current vs. Temperature

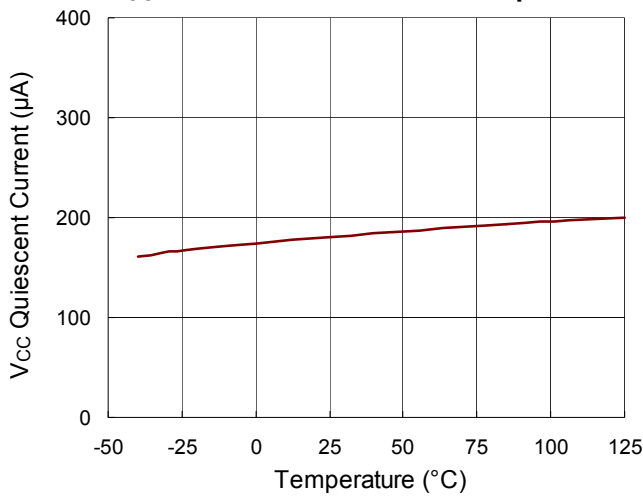

Output Sourcing Current vs. Temperature

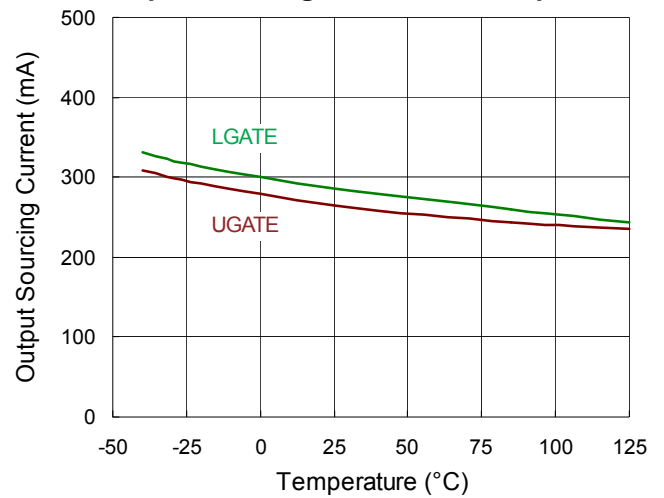

Output Sourcing Current vs. V_{CC} or $V_{BOOT-LX}$

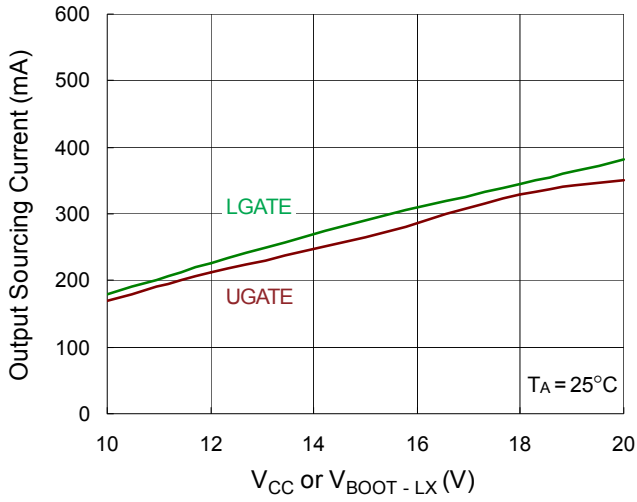

Output Sinking Current vs. Temperature

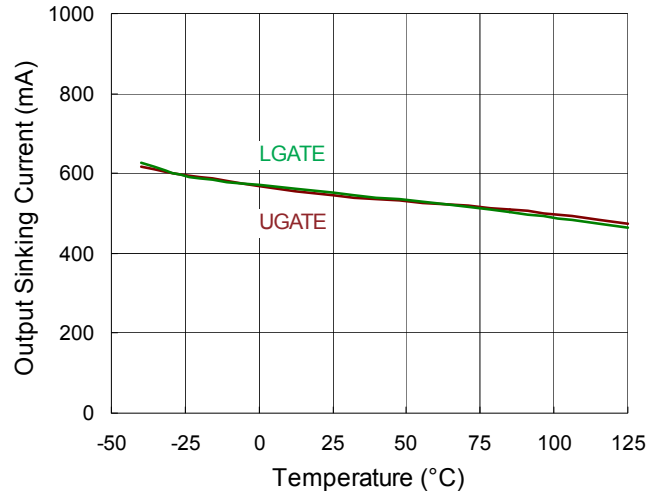

Output Sinking Current vs. V_{CC} or $V_{BOOT-LX}$

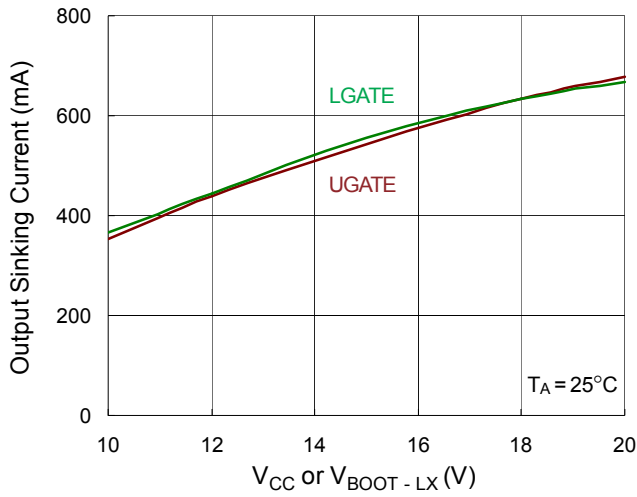

$V_{THON_VCC} / V_{THOFF_VCC}$ vs. Temperature

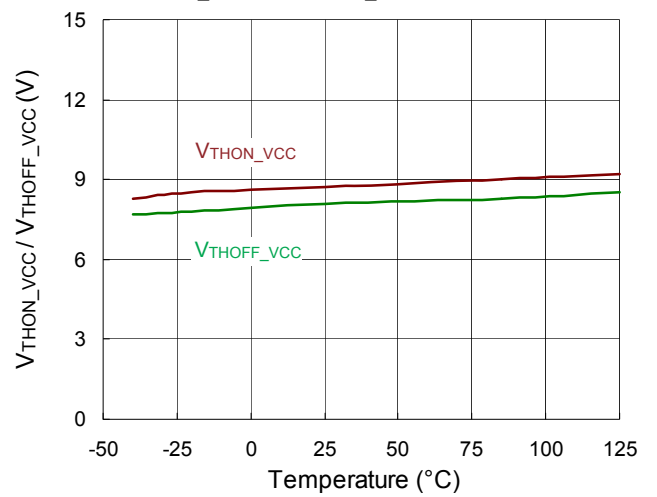

$V_{THON_BOOT} / V_{THOFF_BOOT}$ vs. Temperature

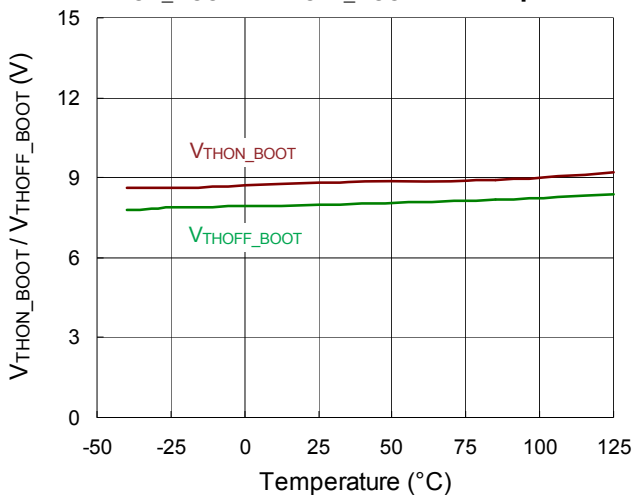

Application Information

Timing Diagram and Dynamic Waveforms

Figure 1 is the RT7028A/B input / output timing diagram, and Figure 2, Figure 3 are the definition of dynamic characteristics. You can know those definitions and the relationship between input and output from these figures. For example : t_{ON} , t_{OFF} , t_R , t_F , t_M ...

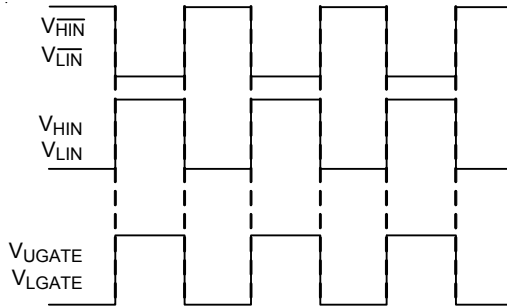

Figure 1. Input/Output Timing Diagram

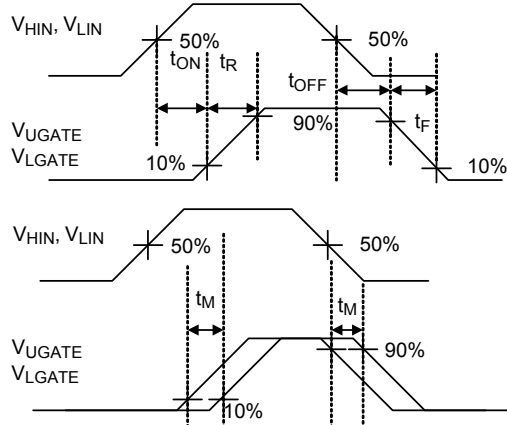

Figure 2. Dynamic Electrical Characteristics Definition for the RT7028A

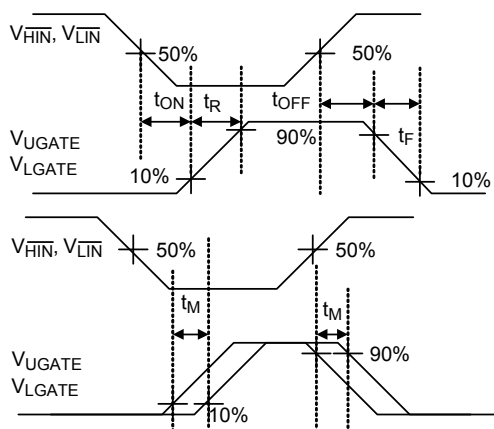

Figure 3. Dynamic Electrical Characteristics Definition for the RT7028B

Matched Propagation Delays between Both Channels

Because the IC internal level shifter circuit causes the propagation delay of the high-side output signal, shown in Figure 4. The RT7028A/B adds a propagation delay matching circuit in the low-side logic circuit, so that high-side and low-side output signals approximately synchronization.

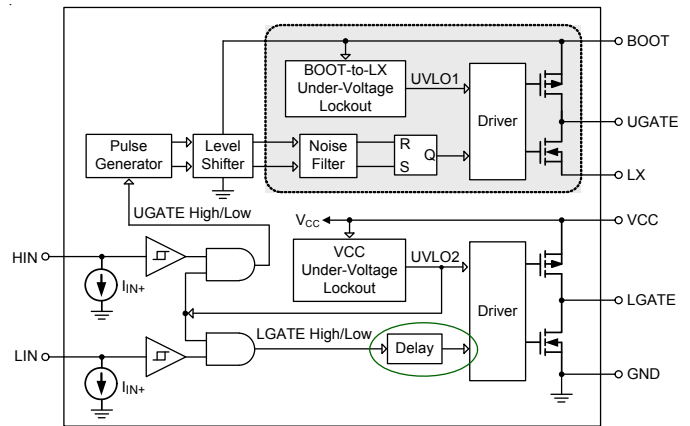

Figure 4. Propagation Delay Matching Circuit

Thermal Considerations

The junction temperature should never exceed the absolute maximum junction temperature $T_{J(MAX)}$, listed under Absolute Maximum Ratings, to avoid permanent damage to the device. The maximum allowable power dissipation depends on the thermal resistance of the IC package, the PCB layout, the rate of surrounding airflow, and the difference between the junction and ambient temperatures. The maximum power dissipation can be calculated using the following formula :

$$P_{D(MAX)} = (T_{J(MAX)} - T_A) / \theta_{JA}$$

where $T_{J(MAX)}$ is the maximum junction temperature, T_A is the ambient temperature, and θ_{JA} is the junction-to-ambient thermal resistance.

For continuous operation, the maximum operating junction temperature indicated under Recommended Operating Conditions is 125°C. The junction-to-ambient thermal resistance, θ_{JA} , is highly package dependent. For a SOP-8 package, the thermal resistance, θ_{JA} , is 188°C/W on a

standard JEDEC 51-7 high effective-thermal-conductivity four-layer test board. The maximum power dissipation at $T_A = 25^\circ\text{C}$ can be calculated as below :

$$P_{D(\text{MAX})} = (125^\circ\text{C} - 25^\circ\text{C}) / (188^\circ\text{C}/\text{W}) = 0.53\text{W for a SOP-8 package.}$$

The maximum power dissipation depends on the operating ambient temperature for the fixed $T_{J(\text{MAX})}$ and the thermal resistance, θ_{JA} . The derating curves in Figure 5 allows the designer to see the effect of rising ambient temperature on the maximum power dissipation.

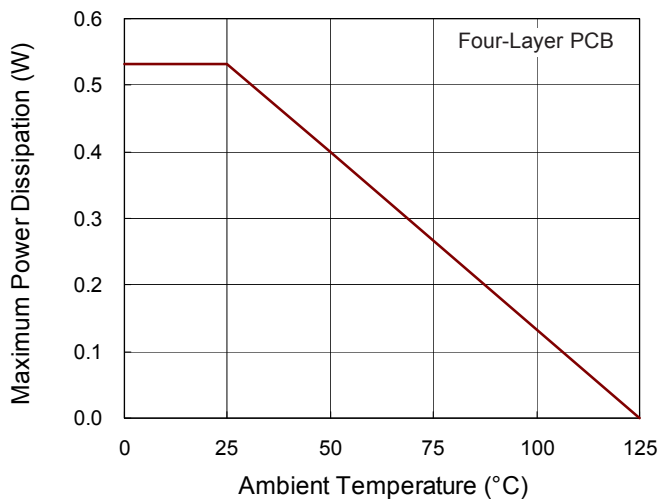

Figure 5. Derating Curve of Maximum Power Dissipation

Layout Consideration

A proper PCB layout for power supply can reduce unnecessary waveform noise and electromagnetic interference problems to ensure proper system operation, please refer to the following PCB layout considerations :

- ▶ For the high voltage and high current loop layout of power supply should be as thick and short. Avoid excessive layout generated parasitic inductance and resistors to cause significant noise.
- ▶ In order to shorten the length of IC layout, you need to consider the relative placement for IC and the power switches. It is recommended that the power switches placed in a symmetrical manner, and the IC close to high-side and low-side elements.
- ▶ In order to reduce the noise coupling, it is recommended that the ground layout should not be placed under or

near the high voltage floating side.

- ▶ The layout between high-side and low-side power switches should be thick and straight, avoiding the formation of long loops. Too long distance will increase the loop area, and electromagnetic interference suppression capabilities would be affected. However, too short distance may cause overheating situation. It is necessary to consider the most appropriate way.
- ▶ Refer to typical application circuit, the VCC capacitor (C1), BOOT to LX capacitor (C_{BOOT}), and bootstrap diode (D_{BOOT}) need to be placed as close to the IC as possible to minimize parasitic inductance and resistance. The C_{BOOT} selected range is from $0.1\mu\text{F}$ to $0.47\mu\text{F}$, and the VCC capacitor (C1) is greater than ten times C_{BOOT} . It is recommended to use fast or ultra fast reverse recovery time bootstrap diode D_{BOOT} .
- ▶ In Figure 6, the LX pin voltage drop can be improved by adding R_{LX} ($R_{\text{LX}} = 1$ to 10Ω), because the dv/dt is affected by $(R_{\text{LX}} + R_{\text{UGATE}})$.

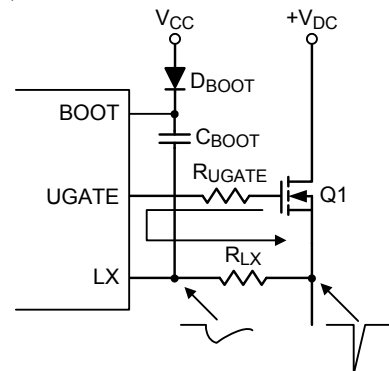

Figure 6. LX Pin Resistor

- ▶ If the gate current loop opens circuit for some factors, at this time the current flows through the gate loop via the power MOSFET drain-to-gate parasitic capacitor. The current will charge the gate-to-source parasitic capacitor to result in power MOSFET wrong action. The power switches can be damaged or burned out, the resistors (about least $10\text{k}\Omega$) are connected between the gate and source pin can prevent malfunction of the power switches.

- ▶ The selection of larger parasitic capacitor power switch or gate resistor may result in too long turn-off time making the high-side and low-side power switches shoot through. In order to prevent the situation, reverse parallel with diodes (D_{UGATE} & D_{LGATE} Preliminary Preliminary_{ATE}) in the R_{UGATE} and R_{LGATE} (shown in Figure 7), providing a fast discharge path for the power switches in a short time to complete the closing operation.

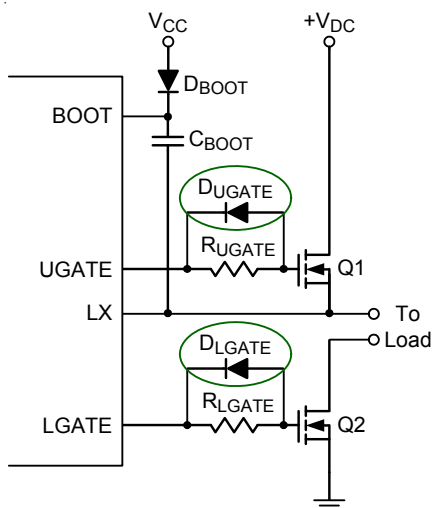
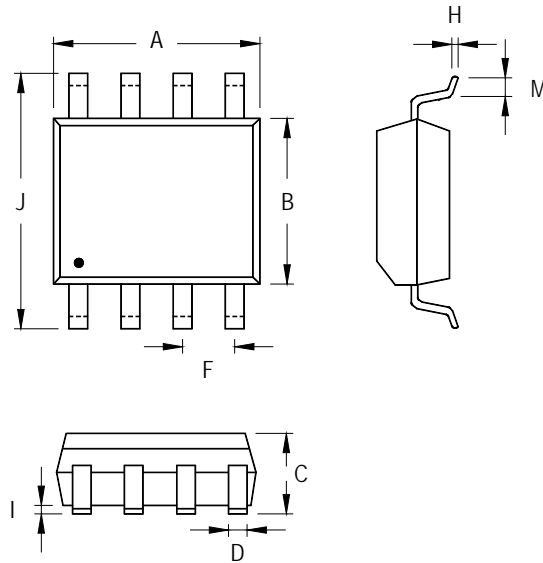

Figure 7. Reverse Parallel with Diodes

Outline Dimension



Symbol	Dimensions In Millimeters		Dimensions In Inches	
	Min	Max	Min	Max
A	4.801	5.004	0.189	0.197
B	3.810	3.988	0.150	0.157
C	1.346	1.753	0.053	0.069
D	0.330	0.508	0.013	0.020
F	1.194	1.346	0.047	0.053
H	0.170	0.254	0.007	0.010
I	0.050	0.254	0.002	0.010
J	5.791	6.200	0.228	0.244
M	0.400	1.270	0.016	0.050

8-Lead SOP Plastic Package

Richtek Technology Corporation

14F, No. 8, Tai Yuen 1st Street, Chupei City
 Hsinchu, Taiwan, R.O.C.
 Tel: (8863)5526789

Richtek products are sold by description only. Richtek reserves the right to change the circuitry and/or specifications without notice at any time. Customers should obtain the latest relevant information and data sheets before placing orders and should verify that such information is current and complete. Richtek cannot assume responsibility for use of any circuitry other than circuitry entirely embodied in a Richtek product. Information furnished by Richtek is believed to be accurate and reliable. However, no responsibility is assumed by Richtek or its subsidiaries for its use; nor for any infringements of patents or other rights of third parties which may result from its use. No license is granted by implication or otherwise under any patent or patent rights of Richtek or its subsidiaries.